



**KLX250
D-TRACKER X**



Motorcycle Service Manual

Quick Reference Guide

General Information	1
Periodic Maintenance	2
Fuel System (DFI)	3
Cooling System	4
Engine Top End	5
Clutch	6
Engine Lubrication System	7
Engine Removal/Installation	8
Crankshaft/Transmission	9
Wheels/Tires	10
Final Drive	11
Brakes	12
Suspension	13
Steering	14
Frame	15
Electrical System	16
Appendix	17

This quick reference guide will assist you in locating a desired topic or procedure.

- Bend the pages back to match the black tab of the desired chapter number with the black tab on the edge at each table of contents page.
- Refer to the sectional table of contents for the exact pages to locate the specific topic required.



**KLX250
D-TRACKER X**

Motorcycle Service Manual

All rights reserved. No parts of this publication may be reproduced, stored in a retrieval system, or transmitted in any form or by any means, electronic mechanical photocopying, recording or otherwise, without the prior written permission of Quality Assurance Division/Motorcycle & Engine Company/Kawasaki Heavy Industries, Ltd., Japan.

No liability can be accepted for any inaccuracies or omissions in this publication, although every possible care has been taken to make it as complete and accurate as possible.

The right is reserved to make changes at any time without prior notice and without incurring an obligation to make such changes to products manufactured previously. See your Motorcycle dealer for the latest information on product improvements incorporated after this publication.

All information contained in this publication is based on the latest product information available at the time of publication. Illustrations and photographs in this publication are intended for reference use only and may not depict actual model component parts.

LIST OF ABBREVIATIONS

A	ampere(s)	lb	pound(s)
ABDC	after bottom dead center	m	meter(s)
AC	alternating current	min	minute(s)
ATDC	after top dead center	N	newton(s)
BBDC	before bottom dead center	Pa	pascal(s)
BDC	bottom dead center	PS	horsepower
BTDC	before top dead center	psi	pound(s) per square inch
°C	degree(s) Celsius	r	revolution
DC	direct current	rpm	revolution(s) per minute
F	farad(s)	TDC	top dead center
°F	degree(s) Fahrenheit	TIR	total indicator reading
ft	foot, feet	V	volt(s)
g	gram(s)	W	watt(s)
h	hour(s)	Ω	ohm(s)
L	liter(s)		

COUNTRY AND AREA CODES

BR	Brazil	SEA	Southeast Asia
EUR	Europe	TH	Thailand
IN	Indonesia		

Foreword

This manual is designed primarily for use by trained mechanics in a properly equipped shop. However, it contains enough detail and basic information to make it useful to the owner who desires to perform his own basic maintenance and repair work. A basic knowledge of mechanics, the proper use of tools, and workshop procedures must be understood in order to carry out maintenance and repair satisfactorily. Whenever the owner has insufficient experience or doubts his ability to do the work, all adjustments, maintenance, and repair should be carried out only by qualified mechanics.

In order to perform the work efficiently and to avoid costly mistakes, read the text, thoroughly familiarize yourself with the procedures before starting work, and then do the work carefully in a clean area. Whenever special tools or equipment are specified, do not use makeshift tools or equipment. Precision measurements can only be made if the proper instruments are used, and the use of substitute tools may adversely affect safe operation.

For the duration of the warranty period, we recommend that all repairs and scheduled maintenance be performed in accordance with this service manual. Any owner maintenance or repair procedure not performed in accordance with this manual may void the warranty.

To get the longest life out of your vehicle:

- Follow the Periodic Maintenance Chart in the Service Manual.
- Be alert for problems and non-scheduled maintenance.
- Use proper tools and genuine Kawasaki Motorcycle parts. Special tools, gauges, and testers that are necessary when servicing Kawasaki motorcycles are introduced by the Service Manual. Genuine parts provided as spare parts are listed in the Parts Catalog.
- Follow the procedures in this manual carefully. Don't take shortcuts.
- Remember to keep complete records of maintenance and repair with dates and any new parts installed.

How to Use This Manual

In this manual, the product is divided into its major systems and these systems make up the manual's chapters.

The Quick Reference Guide shows you all of the product's system and assists in locating their chapters. Each chapter in turn has its own comprehensive Table of Contents.

For example, if you want ignition coil information, use the Quick Reference Guide to locate the Electrical System chapter. Then, use the Table of Contents on the first page of the chapter to find the ignition coil section.

Whenever you see symbols, heed their instructions! Always follow safe operating and maintenance practices.

DANGER

DANGER indicates a hazardous situation which, if not avoided, will result in death or serious injury.

WARNING

WARNING indicates a hazardous situation which, if not avoided, could result in death or serious injury.

CAUTION

CAUTION indicates a hazardous situation which, if not avoided, could result in minor or moderate injury.

NOTICE

NOTICE is used to address practices not related to personal injury.

This manual contains four more symbols which will help you distinguish different types of information.

NOTE

○ *This note symbol indicates points of particular interest for more efficient and convenient operation.*

- Indicates a procedural step or work to be done.
- Indicates a procedural sub-step or how to do the work of the procedural step it follows. It also precedes the text of a NOTE.
- ★ Indicates a conditional step or what action to take based on the results of the test or inspection in the procedural step or sub-step it follows.

In most chapters an exploded view illustration of the system components follows the Table of Contents. In these illustrations you will find the instructions indicating which parts require specified tightening torque, oil, grease or a locking agent during assembly.

General Information

Table of Contents

Before Servicing	1-2
Model Identification.....	1-7
Model Identification.....	1-8
General Specifications.....	1-9
Unit Conversion Table	1-15

1-2 GENERAL INFORMATION

Before Servicing

Before starting to perform an inspection service or carry out a disassembly and reassembly operation on a motorcycle, read the precautions given below. To facilitate actual operations, notes, illustrations, photographs, cautions, and detailed descriptions have been included in each chapter wherever necessary. This section explains the items that require particular attention during the removal and reinstallation or disassembly and reassembly of general parts.

Especially note the following.

Battery Ground

Before completing any service on the motorcycle, disconnect the battery cables from the battery to prevent the engine from accidentally turning over. Disconnect the ground cable (-) first and then the positive (+). When completed with the service, first connect the positive (+) cable to the positive (+) terminal of the battery then the negative (-) cable to the negative terminal.

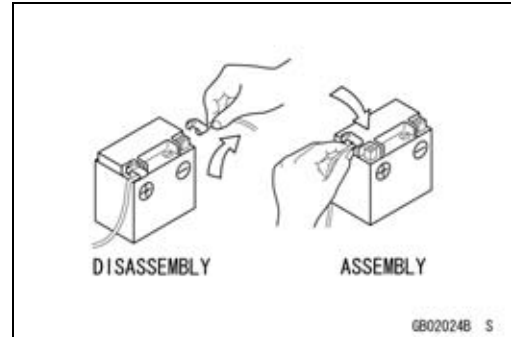

Edges of Parts

Lift large or heavy parts wearing gloves to prevent injury from possible sharp edges on the parts.

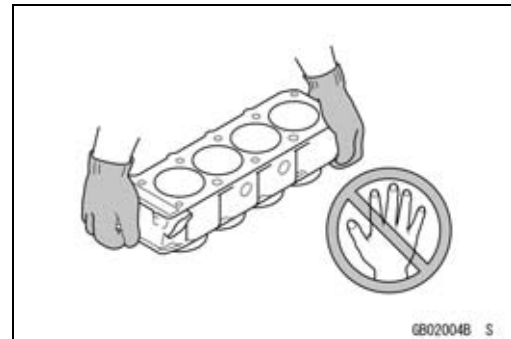

Solvent

Use a high-flash point solvent when cleaning parts. High-flash point solvent should be used according to directions of the solvent manufacturer.

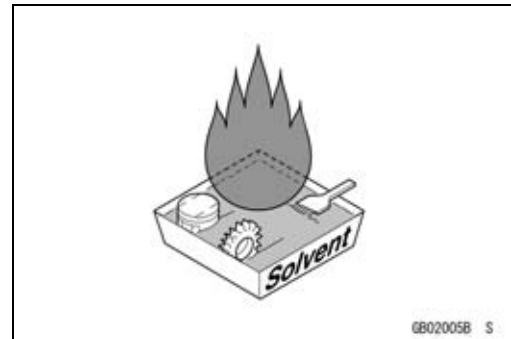

Cleaning vehicle before disassembly

Clean the vehicle thoroughly before disassembly. Dirt or other foreign materials entering into sealed areas during vehicle disassembly can cause excessive wear and decrease performance of the vehicle.

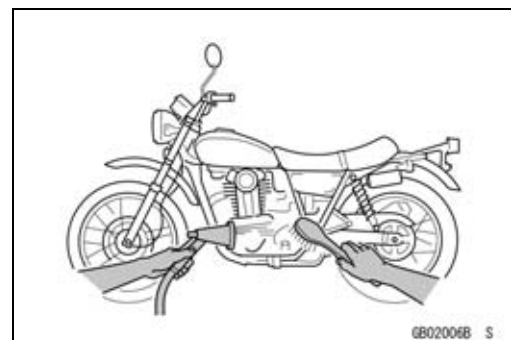

Before Servicing

Arrangement and Cleaning of Removed Parts

Disassembled parts are easy to confuse. Arrange the parts according to the order the parts were disassembled and clean the parts in order prior to assembly.

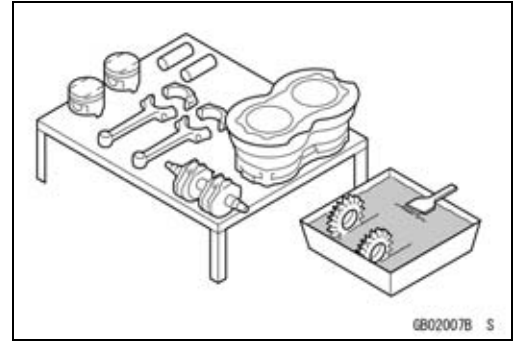

Storage of Removed Parts

After all the parts including subassembly parts have been cleaned, store the parts in a clean area. Put a clean cloth or plastic sheet over the parts to protect from any foreign materials that may collect before re-assembly.

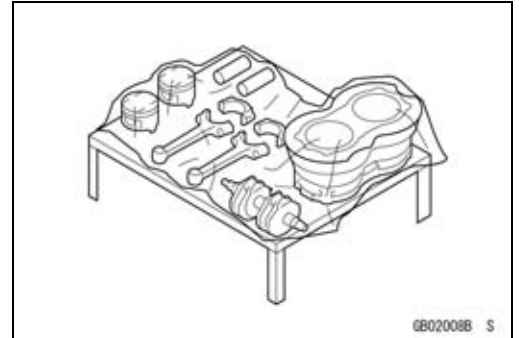

Inspection

Reuse of worn or damaged parts may lead to serious accident. Visually inspect removed parts for corrosion, discoloration, or other damage. Refer to the appropriate sections of this manual for service limits on individual parts. Replace the parts if any damage has been found or if the part is beyond its service limit.

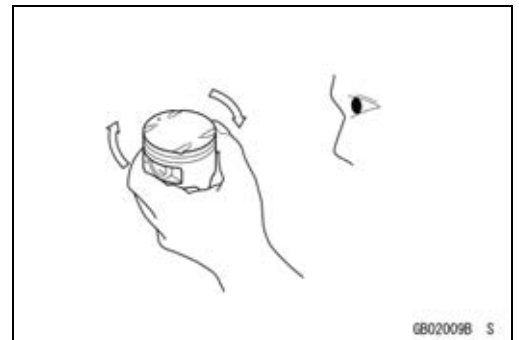

Replacement Parts

Replacement Parts must be KAWASAKI genuine or recommended by KAWASAKI. Gaskets, O-rings, oil seals, grease seals, circlips, cotter pins or self-locking nuts must be replaced with new ones whenever disassembled.

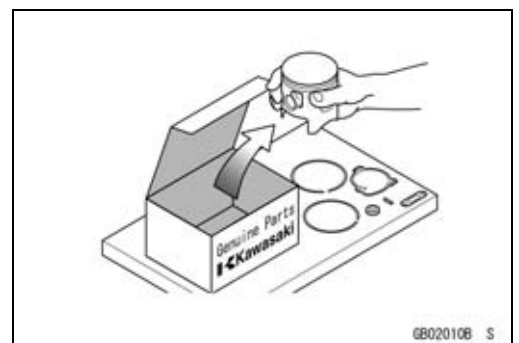

Assembly Order

In most cases assembly order is the reverse of disassembly, however, if assembly order is provided in this Service Manual, follow the procedures given.

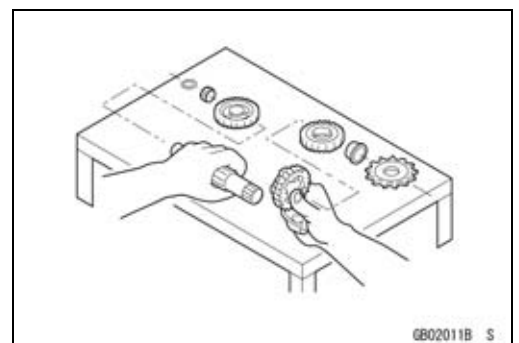

1-4 GENERAL INFORMATION

Before Servicing

Tightening Sequence

Generally, when installing a part with several bolts, nuts, or screws, start them all in their holes and tighten them to a snug fit. Then tighten them according to the specified sequence to prevent case warpage or deformation which can lead to malfunction. Conversely when loosening the bolts, nuts, or screws, first loosen all of them by about a quarter turn and then remove them. If the specified tightening sequence is not indicated, tighten the fasteners alternating diagonally.

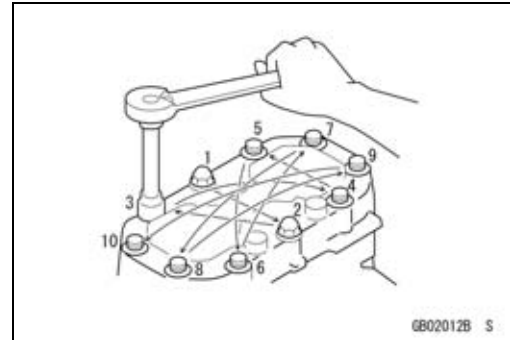

Tightening Torque

Incorrect torque applied to a bolt, nut, or screw may lead to serious damage. Tighten fasteners to the specified torque using a good quality torque wrench.

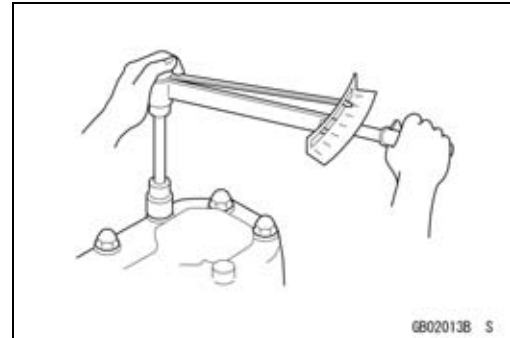

Force

Use common sense during disassembly and assembly, excessive force can cause expensive or hard to repair damage. When necessary, remove screws that have a non-permanent locking agent applied using an impact driver. Use a plastic-faced mallet whenever tapping is necessary.

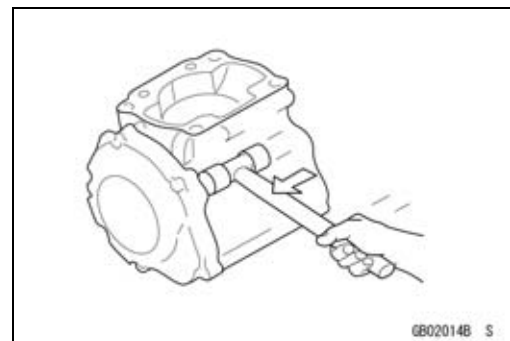

Gasket, O-ring

Hardening, shrinkage, or damage of both gaskets and O-rings after disassembly can reduce sealing performance. Remove the old gaskets and clean the sealing surfaces thoroughly so that no gasket material or other material remains. Install the new gaskets and replace the used O-rings when re-assembling.

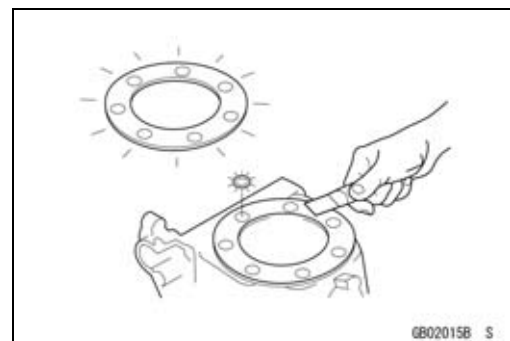

Liquid Gasket, Non-permanent Locking Agent

For applications that require Liquid Gasket or a Non-permanent Locking Agent, clean the surfaces so that no oil residue remains before applying liquid gasket or non-permanent locking agent. Do not apply them excessively. Excessive application can clog oil passages and cause serious damage.



Before Servicing

Press

For items such as bearings or oil seals that must be pressed into place, apply small amount of oil to the contact area. Be sure to maintain proper alignment and use smooth movements when installing.

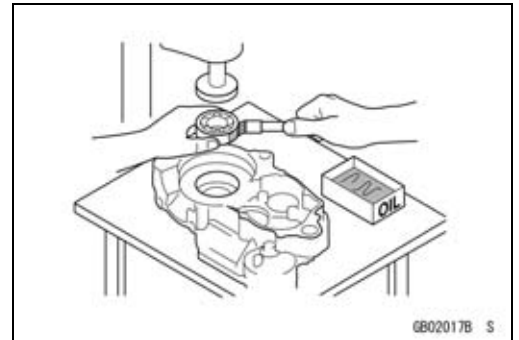

Ball Bearing and Needle Bearing

Do not remove pressed ball or needle unless removal is absolutely necessary. Replace with new ones whenever removed. Press bearings with the manufacturer and size marks facing out. Press the bearing into place by putting pressure on the correct bearing race as shown.

Pressing the incorrect race can cause pressure between the inner and outer race and result in bearing damage.

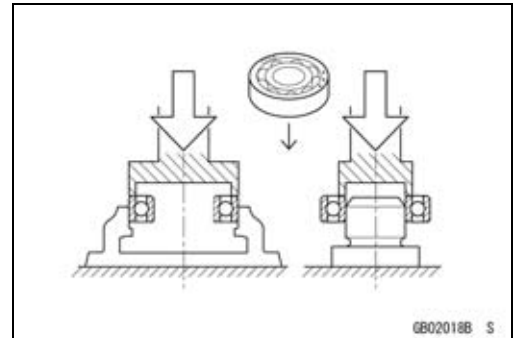

Oil Seal, Grease Seal

Do not remove pressed oil or grease seals unless removal is necessary. Replace with new ones whenever removed. Press new oil seals with manufacture and size marks facing out. Make sure the seal is aligned properly when installing.

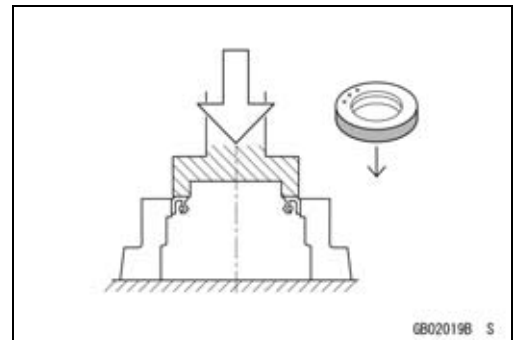

Apply specified grease to the lip of seal before installing the seal.

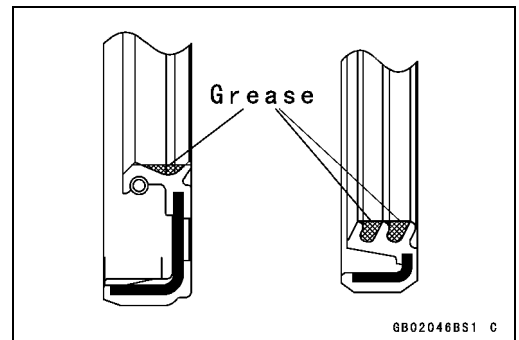

Circlips, Cotter Pins

Replace the circlips or cotter pins that were removed with new ones. Take care not to open the clip excessively when installing to prevent deformation.

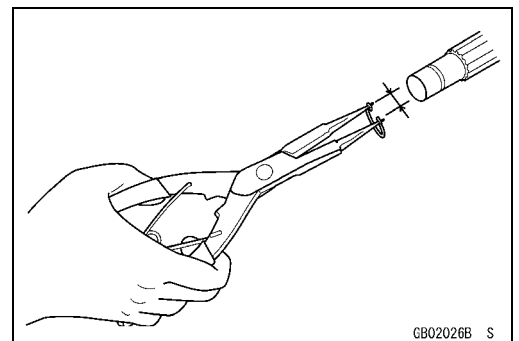

1-6 GENERAL INFORMATION

Before Servicing

Lubrication

It is important to lubricate rotating or sliding parts during assembly to minimize wear during initial operation. Lubrication points are called out throughout this manual, apply the specific oil or grease as specified.

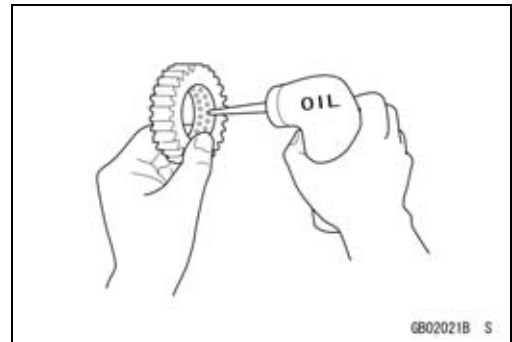

Direction of Engine Rotation

When rotating the crankshaft by hand, the free play amount of rotating direction will affect the adjustment. Rotate the crankshaft to positive direction (clockwise viewed from output side).

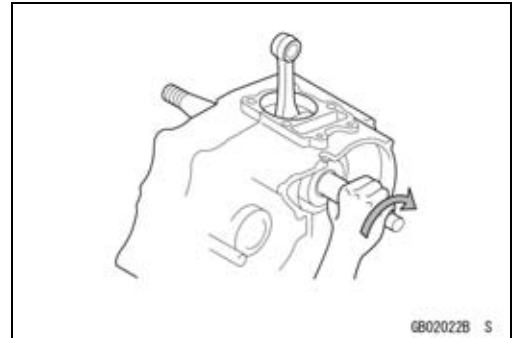

Electrical Leads

A two-color lead is identified first by the primary color and then the stripe color. Unless instructed otherwise, electrical leads must be connected to those of the same color.

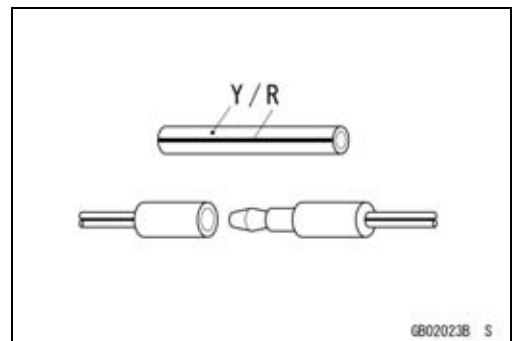

Instrument

Use a meter that has enough accuracy for an accurate measurement. Read the manufacturer's instructions thoroughly before using the meter. Incorrect values may lead to improper adjustments.

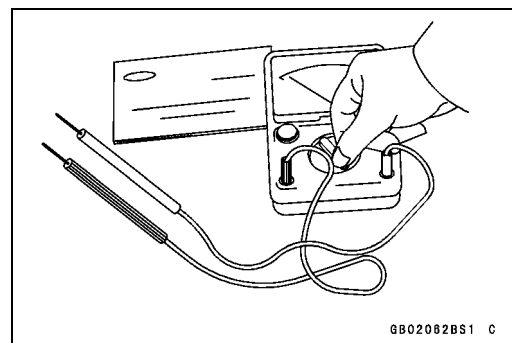

Model Identification

KLX250S9F Left Side View



68038424 P

KLX250S9F Right Side View



68038425 P

Frame Number



68038406 P

Engine Number



68038409 P

1-8 GENERAL INFORMATION

Model Identification

KLX250V9F Left Side View



KLX250V9F Right Side View



General Specifications

Items	KLX250S9F ~ SBF
<p>Dimensions</p> <p>Overall Length Overall Width Overall Height Wheelbase Road Clearance Seat Height Curb Mass: Front Rear Fuel Tank Capacity</p>	<p>2 200 mm (86.61 in.) 820 mm (32.3 in.) (IN, EUR, SEA) 1 205 mm (47.44 in.), (TH) 1 190 mm (46.85 in.) 1 430 mm (56.30 in.) 285 mm (11.2 in.) 890 mm (35.0 in.) (TH, EUR) 138 kg (304 lb), (IN) 137 kg (302 lb), (SEA) 139 kg (306 lb) (IN, EUR) 63 kg (139 lb), (TH, SEA) 64 kg (141 lb) (IN, TH) 74 kg (163 lb), (EUR, SEA) 75 kg (165 lb) 7.7 L (2.0 US gal)</p>
<p>Performance</p> <p>Minimum Turning Radius</p>	<p>2.4 m (7.9 ft)</p>
<p>Engine</p> <p>Type Cooling System Bore and Stroke Displacement Compression Ratio Carburetion System Starting System Ignition System Timing Advance Ignition Timing Spark Plug Valve Timing: Inlet: Open Close Duration Exhaust: Open Close Duration Lubrication System Engine Oil: Type Viscosity Capacity: KLX250S9F ~ SAF KLX250SBF</p>	<p>4-stroke, 1-cylinder, DOHC, 4-valve Liquid-cooled 72.0 × 61.2 mm (2.83 × 2.41 in.) 249 cm³ (15.2 cu in.) 11 : 1 DFI (Digital Fuel Injection) System, keihin single barrel ϕ34 Electric starter motor CDI Electronically advanced (IN) BTDC 10° @1 300 r/min (rpm) ~ BTDC 39° @11 000 r/min (rpm) (TH, EUR, SEA) BTDC 10° @1 300 r/min (rpm) ~ BTDC 34° @11 000 r/min (rpm) NGK CR8E BTDC 22° ABDC 62° 264° BBDC 61° ATDC 19° 260° Forced lubrication (wet sump) API SG, SH, SJ, SL or SM with JASO MA, MA1 or MA2 SAE10W-40 1.5 L (1.6 US qt) (when engine is completely dry) 1.3 L (1.4 US qt) (when engine is completely dry)</p>

1-10 GENERAL INFORMATION

General Specifications

Items	KLX250S9F ~ SBF
Drive Train Primary Reduction System: Type Reduction Ratio Clutch Type Transmission: Type Gear Ratios: 1st 2nd 3rd 4th 5th 6th Final Drive System: Type Reduction Ratio Overall Drive Ratio	Gear drive 2.800 (84/30) Wet multi disc 6-speed, constant mesh, return shift 3.000 (30/10) 2.000 (30/15) 1.500 (27/18) 1.250 (25/20) 1.050 (21/20) 0.952 (20/21) Chain drive 3.000 (42/14) 8.000 @Top gear
Frame Type Caster (Rake Angle) Trail Rim Size: Front Rear Front Tire: Type Size Rear Tire: Type Size Front Suspension: Type Wheel Travel Rear Suspension: Type Wheel Travel Brake Type: Front Rear	Tubular, semi-double cradle 26.5° 105 mm (4.13 in.) 21 × 1.60 18 × 2.15 Tube type 3.00-21 51P Tube type 4.60-18 63P Telescopic fork 255 mm (10.0 in.) Swingarm (uni-trak) 230 mm (9.06 in.) Single disc brake Single disc brake
Electrical Equipment Battery	12 V 6 Ah

General Specifications

Items	KLX250S9F ~ SBF
Headlight:	
Type	Semi-sealed beam
Bulb	(TH) 12 V 30/30 W × 2 (quartz halogen)
	(IN, EUR, SEA) 12 V 60/55 W (quartz halogen)
Tail/Brake Light	12 V 5/21 W
Alternator:	
Type	Three-phase AC
Rated Output	17.4 A/14 V @5 000 r/min (rpm)

Specifications subject to change without notice, and may not apply to every country.

1-12 GENERAL INFORMATION

General Specifications

Items	KLX250V9F ~ VAF
Dimensions	
Overall Length	2 130 mm (83.86 in.)
Overall Width	795 mm (31.3 in.)
Overall Height	(TH) 1 125 mm (44.29 in.) (BR, IN) 1 140 mm (44.88 in.)
Wheelbase	1 420 mm (55.91 in.)
Road Clearance	225 mm (8.86 in.)
Seat Height	860 mm (33.9 in.)
Curb Mass:	139 kg (306 lb)
Front	(TH) 65 kg (143 lb) (BR, IN) 64 kg (141 lb)
Rear	(TH) 74 kg (163 lb) (BR, IN) 75 kg (165 lb)
Fuel Tank Capacity	7.7 L (2.0 US gal)
Performance	
Minimum Turning Radius	2.3 m (7.5 ft)
Engine	
Type	4-stroke, 1-cylinder, DOHC, 4-valve
Cooling System	Liquid-cooled
Bore and Stroke	72.0 × 61.2 mm (2.83 × 2.41 in.)
Displacement	249 cm ³ (15.2 cu in.)
Compression Ratio	11 : 1
Carburetion System	DFI (Digital Fuel Injection) System, keihin single barrel ϕ 34
Starting System	Electric starter motor
Ignition System	CDI
Timing Advance	Electronically advanced
Ignition Timing	BTDC 10° @1 300 r/min (rpm) ~ BTDC 34° @11 000 r/min (rpm)
Spark Plug	NGK CR8E
Valve Timing:	
Inlet:	
Open	BTDC 22°
Close	ABDC 62°
Duration	264°
Exhaust:	
Open	BBDC 61°
Close	ATDC 19°
Duration	260°
Lubrication System	Forced lubrication (wet sump)
Engine Oil:	
Type	API SG, SH, SJ, SL or SM with JASO MA, MA1 or MA2
Viscosity	SAE10W-40
Capacity	1.5 L (1.6 US qt) (when engine is completely dry)

General Specifications

Items	KLX250V9F ~ VAF
<p>Drive Train</p> <p>Primary Reduction System:</p> <p> Type</p> <p> Reduction Ratio</p> <p>Clutch Type</p> <p>Transmission:</p> <p> Type</p> <p> Gear Ratios:</p> <p> 1st</p> <p> 2nd</p> <p> 3rd</p> <p> 4th</p> <p> 5th</p> <p> 6th</p> <p>Final Drive System:</p> <p> Type</p> <p> Reduction Ratio</p> <p> Overall Drive Ratio</p>	<p>Gear drive</p> <p>2.800 (84/30)</p> <p>Wet multi disc</p> <p>6-speed, constant mesh, return shift</p> <p>3.000 (30/10)</p> <p>2.000 (30/15)</p> <p>1.500 (27/18)</p> <p>1.250 (25/20)</p> <p>1.050 (21/20)</p> <p>0.952 (20/21)</p> <p>Chain drive</p> <p>2.786 (39/14)</p> <p>7.429 @Top gear</p>
<p>Frame</p> <p>Type</p> <p>Caster (Rake Angle)</p> <p>Trail</p> <p>Rim Size:</p> <p> Front</p> <p> Rear</p> <p>Front Tire:</p> <p> Type</p> <p> Size</p> <p>Rear Tire:</p> <p> Type</p> <p> Size</p> <p>Front Suspension:</p> <p> Type</p> <p> Wheel Travel</p> <p>Rear Suspension:</p> <p> Type</p> <p> Wheel Travel</p> <p>Brake Type:</p> <p> Front</p> <p> Rear</p>	<p>Tubular, semi-double cradle</p> <p>25.5°</p> <p>73 mm (2.87 in.)</p> <p>17 × 3.00</p> <p>17 × 4.00</p> <p>Tube type</p> <p>110/70-17 M/C 54S</p> <p>Tube type</p> <p>130/70-17 M/C 62S</p> <p>Telescopic fork</p> <p>230 mm (9.06 in.)</p> <p>Swingarm (uni-trak)</p> <p>205 mm (8.07 in.)</p> <p>Single disc brake</p> <p>Single disc brake</p>
<p>Electrical Equipment</p> <p>Battery</p>	<p>12 V 6 Ah</p>

1-14 GENERAL INFORMATION

General Specifications

Items	KLX250V9F ~ VAF
Headlight:	
Type	Semi-sealed beam
Bulb	(TH) 12 V 30/30 W × 2 (quartz halogen)
	(BR, IN) 12 V 60/55 W (quartz halogen)
Tail/Brake Light	12 V 5/21 W
Alternator:	
Type	Three-phase AC
Rated Output	17.4 A/14 V @5 000 r/min (rpm)

Unit Conversion Table

Prefixes for Units

Prefix	Symbol	Power
mega	M	× 1 000 000
kilo	k	× 1 000
centi	c	× 0.01
milli	m	× 0.001
micro	μ	× 0.000001

Units of Mass

kg	×	2.205	=	lb
g	×	0.03527	=	oz

Units of Volume

L	×	0.2642	=	gal (US)
L	×	0.2200	=	gal (IMP)
L	×	1.057	=	qt (US)
L	×	0.8799	=	qt (IMP)
L	×	2.113	=	pint (US)
L	×	1.816	=	pint (IMP)
mL	×	0.03381	=	oz (US)
mL	×	0.02816	=	oz (IMP)
mL	×	0.06102	=	cu in

Units of Force

N	×	0.1020	=	kg
N	×	0.2248	=	lb
kg	×	9.807	=	N
kg	×	2.205	=	lb

Units of Temperature

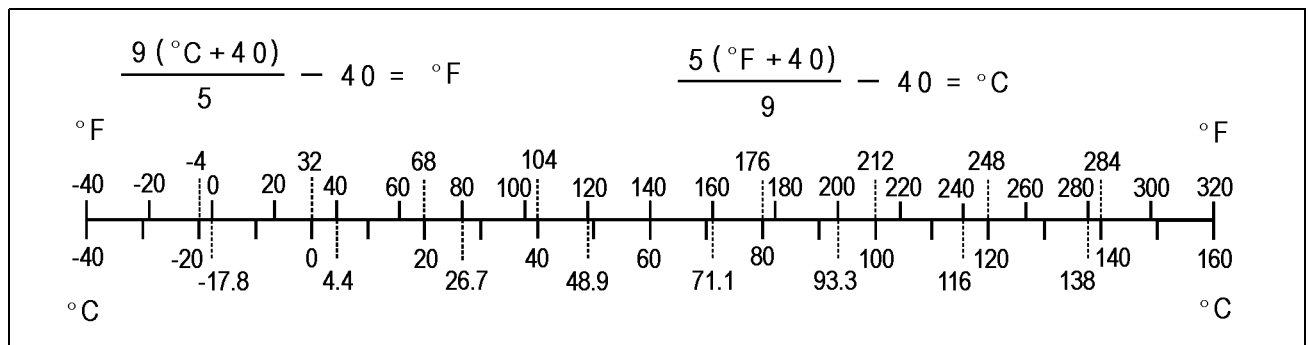

Units of Length

km	×	0.6214	=	mile
m	×	3.281	=	ft
mm	×	0.03937	=	in

Units of Torque

N·m	×	0.1020	=	kgf·m
N·m	×	0.7376	=	ft·lb
N·m	×	8.851	=	in·lb
kgf·m	×	9.807	=	N·m
kgf·m	×	7.233	=	ft·lb
kgf·m	×	86.80	=	in·lb

Units of Pressure

kPa	×	0.01020	=	kgf/cm ²
kPa	×	0.1450	=	psi
kPa	×	0.7501	=	cmHg
kgf/cm ²	×	98.07	=	kPa
kgf/cm ²	×	14.22	=	psi
cmHg	×	1.333	=	kPa

Units of Speed

km/h	×	0.6214	=	mph
------	---	--------	---	-----

Units of Power

kW	×	1.360	=	PS
kW	×	1.341	=	HP
PS	×	0.7355	=	kW
PS	×	0.9863	=	HP

Periodic Maintenance

Table of Contents

Periodic Maintenance Chart	2-3
Torque and Locking Agent.....	2-6
Specifications	2-11
Special Tools	2-13
Periodic Maintenance Procedures.....	2-14
Fuel System (DFI).....	2-14
Air Cleaner Element Cleaning.....	2-14
Throttle Control System Inspection.....	2-15
Idle Speed Inspection	2-15
Idle Speed Adjustment.....	2-16
Fuel Hose Inspection (fuel leak, damage, installation condition).....	2-16
Evaporative Emission Control System Inspection (SEA and TH Models)	2-16
Cooling System.....	2-17
Coolant Level Inspection.....	2-17
Radiator Hose Inspection (coolant leak, damage, installation condition).....	2-18
Engine Top End	2-18
Valve Clearance Inspection	2-18
Valve Clearance Adjustment.....	2-19
Air Suction System Damage Inspection	2-22
Clutch.....	2-22
Clutch Operation Inspection.....	2-22
Wheels/Tires	2-23
Air Pressure Inspection.....	2-23
Wheel/Tire Damage Inspection.....	2-23
Tire Tread Wear Inspection.....	2-24
Wheel Bearing Damage Inspection	2-24
Spoke Tightness and Rim Runout Inspection.....	2-25
Drive Train	2-26
Drive Chain Lubrication Condition Inspection.....	2-26
Drive Chain Slack Inspection	2-27
Drive Chain Slack Adjustment	2-27
Wheel Alignment Inspection	2-28
Drive Chain Wear Inspection	2-29
Chain Guide Wear Inspection	2-30
Brake System	2-31
Brake Fluid Leak Inspection.....	2-31
Brake Hose Damage and Installation Condition Inspection.....	2-32
Brake Operation Inspection	2-32
Brake Fluid Level Inspection.....	2-32
Brake Pad Wear Inspection	2-33
Brake Light Switch Operation Inspection	2-33
Suspensions	2-34
Front Forks/Rear Shock Absorber Operation Inspection	2-34
Front Fork Oil Leak Inspection.....	2-35
Rear Shock Absorber Oil Leak Inspection	2-35
Rocker Arm Operation Inspection.....	2-35
Rocker Arm Bearing Lubrication	2-35
Tie-Rod Operation Inspection	2-36
Tie-Rod Bearing Lubrication	2-36
Swingarm Pivot Lubrication	2-36

2-2 PERIODIC MAINTENANCE

Steering System	2-36
Steering Play Inspection	2-36
Steering Play Adjustment.....	2-37
Steering Stem Bearing Lubrication	2-37
Electrical System	2-38
Lights and Switches Operation Inspection.....	2-38
Headlight Aiming Inspection	2-40
Sidestand Switch Operation Inspection	2-41
Engine Stop Switch Operation Inspection.....	2-42
Others	2-43
Chassis Parts Lubrication	2-43
Bolts, Nuts and Fasteners Tightness Inspection.....	2-45
Replacement Parts	2-46
Air Cleaner Element Replacement.....	2-46
Fuel Hose Replacement	2-47
Coolant Change	2-49
Radiator Hose and O-ring Replacement.....	2-51
Engine Oil Change.....	2-51
Oil Filter Replacement	2-52
Brake Hose Replacement	2-53
Brake Fluid Change	2-54
Master Cylinder Rubber Parts Replacement	2-55
Caliper Rubber Parts Replacement	2-57
Spark Plug Replacement	2-60

PERIODIC MAINTENANCE 2-3

Periodic Maintenance Chart

The scheduled maintenance must be done in accordance with this chart to keep the motorcycle in good running condition. **The initial maintenance is vitally important and must not be neglected.**

Periodic Inspection

ITEM	FREQUENCY	* ODOMETER READING							See Page
	Whichever comes first ↓ Every	1 (0.6)	6 (3.75)	12 (7.5)	18 (11.25)	24 (15)	30 (18.75)	36 (22.5)	
Fuel System									
Air cleaner element - clean				•		•		•	2-14
Throttle control system (play, smooth return, no drag) - inspect	year	•		•		•		•	2-15
Idle speed - inspect		•		•		•		•	2-15
Fuel leak - inspect	year	•		•		•		•	2-16
Fuel hose damage - inspect	year	•		•		•		•	2-16
Fuel hose installation condition - inspect	year	•		•		•		•	2-16
Evaporative emission control system function (SEA and TH) - inspect		•	•	•	•	•	•	•	2-16
Cooling System									
Coolant level - inspect		•		•		•		•	2-17
Coolant leak (water hose and pipe) - inspect	year	•		•		•		•	2-18
Water hose damage - inspect	year	•		•		•		•	2-18
Water hose installation condition - inspect	year	•		•		•		•	2-18
Engine Top End									
Valve clearance - inspect				•		•		•	2-18
Air suction system damage - inspect				•		•		•	2-22
Clutch									
Clutch operation (play, disengagement, engagement) - inspect		•		•		•		•	2-22
Wheels and Tires									
Tire air pressure - inspect	year			•		•		•	2-23
Wheel/tire damage - inspect				•		•		•	2-23
Tire tread wear, abnormal wear - inspect				•		•		•	2-24
Wheel bearings damage - inspect	year			•		•		•	2-24
Spoke tightness and rim runout - inspect		•	•	•	•	•	•	•	2-25
Final Drive									
Drive chain lubrication condition - inspect #	Every 600 km (400 mile)								2-26
Drive chain slack - inspect #	Every 1 000 km (600 mile)								2-27

2-4 PERIODIC MAINTENANCE

Periodic Maintenance Chart

ITEM	FREQUENCY	* ODOMETER READING							See Page
		Whichever comes first ↓ Every	1 (0.6)	6 (3.75)	12 (7.5)	18 (11.25)	24 (15)	30 (18.75)	
Drive chain wear - inspect #				•		•		•	2-29
Drive chain guide wear - inspect				•		•		•	2-30
Brakes									
Brake fluid leak - inspect	year	•	•	•	•	•	•	•	2-31
Brake hose damage - inspect	year	•	•	•	•	•	•	•	2-32
Brake hose installation condition - inspect	year	•	•	•	•	•	•	•	2-32
Brake operation (effectiveness, play, no drag) - inspect	year	•	•	•	•	•	•	•	2-32
Brake fluid level - inspect	6 months	•	•	•	•	•	•	•	2-32
Brake pad wear - inspect #			•	•	•	•	•	•	2-33
Brake light switch operation - inspect		•	•	•	•	•	•	•	2-33
Suspension									
Front forks/rear shock absorber operation (damping and smooth stroke) - inspect				•		•		•	2-34
Front forks/rear shock absorber oil leak - inspect	year			•		•		•	2-35
Rocker arm bearings - lubricate						•			2-35
Rocker arm operation - inspect				•		•		•	2-35
Tie-rods operation - inspect				•		•		•	2-36
Tie-rods bearings - lubricate						•			2-36
Swingarm pivot - lubricate						•			2-36
Steering									
Steering play - inspect	year	•		•		•		•	2-36
Steering stem bearings - lubricate	2 years					•			2-37
Electrical System									
Lights and switches operation - inspect	year			•		•		•	2-38
Headlight aiming - inspect	year			•		•		•	2-40
Sidestand switch operation - inspect	year			•		•		•	2-41
Engine stop switch operation - inspect	year			•		•		•	2-42
Others									
Chassis parts - lubricate	year			•		•		•	2-43
Bolts and nuts tightness - inspect		•		•		•		•	2-45

#: Service more frequently when operating in severe conditions; dusty, wet, muddy, high speed or frequent starting/stopping.

PERIODIC MAINTENANCE 2-5

Periodic Maintenance Chart

*: For higher odometer readings, repeat at the frequency interval established here.

Periodic Replacement Parts

ITEM	FREQUENCY	Whichever comes first ↓ Every	* ODOMETER READING × 1 000 km (× 1 000 mile)					See Page
			1 (0.6)	12 (7.5)	24 (15)	36 (22.5)	48 (30.0)	
Air cleaner element # - replace	2 years							2-46
Fuel hose - replace	4 years					•		2-47
Coolant - change	3 years				•			2-49
Radiator hose and O-ring - replace	3 years				•			2-51
Engine oil # - change	year	•	•	•	•	•		2-51
Oil filter - replace	year	•	•	•	•	•		2-52
Brake hose - replace	4 years					•		2-53
Brake fluid - change	2 years			•		•		2-54
Rubber parts of master cylinder and caliper - replace	4 years					•		2-55, 2-57
Spark plug - replace			•	•	•	•		2-60

#: Service more frequently when operating in severe conditions; dusty, wet, muddy, high speed or frequent starting/stopping.

*: For higher odometer readings, repeat at the frequency interval established here.

2-6 PERIODIC MAINTENANCE

Torque and Locking Agent

The following tables list the tightening torque for the major fasteners requiring use of a non-permanent locking agent or silicone sealant etc.

Letters used in the "Remarks" column mean:

AL: Tighten the two clamp bolts alternately two times to ensure even tightening torque.

G: Apply grease.

L: Apply a non-permanent locking agent.

M: Apply molybdenum disulfide grease.

MO: Apply molybdenum disulfide grease oil solution.

(mixture of the engine oil and molybdenum disulfide grease in a weight ratio 10 : 1)

R: Replacement Parts

S: Follow the specified tightening sequence.

Si: Apply silicone grease (ex. PBC grease).

Fastener	Torque			Remarks
	N·m	kgf·m	ft·lb	
Fuel System (DFI)				
Front Air Cleaner Duct Clamp Screw	2.0	0.20	18 in·lb	
ECU Bracket Screws	5.0	0.51	44 in·lb	
Fuel Pump Bolts	9.8	1.0	87 in·lb	L
Inlet Air Temperature Sensor Mounting Screw	1.2	0.12	11 in·lb	
Vehicle-down Sensor Mounting Bolts	6.9	0.70	61 in·lb	
Water Temperature Sensor	12	1.2	106 in·lb	
Oxygen Sensor	25	2.5	18	
Cooling System				
Radiator Hose Clamp Screws	1.5	0.15	13 in·lb	
Radiator Fan Bolts	7.0	0.71	62 in·lb	L
Water Temperature Sensor	12	1.2	106 in·lb	
Water Pump Impeller Nut	7.8	0.80	69 in·lb	
Thermostat Housing Bolts	9.8	1.0	87 in·lb	L
Water Pump Cover Bolts	9.8	1.0	87 in·lb	
Coolant Drain Plug	25	2.5	18	
Radiator Bolts	6.9	0.70	61 in·lb	
Water Hose Fitting Bolts	10	1.0	89 in·lb	
Radiator Cap Stop Screw	2.5	0.25	22 in·lb	
Engine Top End				
Cylinder Head Cover Bolts	7.8	0.80	69 in·lb	
Air Suction Valve Cover Bolts	9.8	1.0	87 in·lb	L
Camshaft Cap Bolts	12	1.2	106 in·lb	S, MO
Throttle Body Assy Holder Bolts	12	1.2	106 in·lb	
Cylinder Head Bolts (M6)	12	1.2	106 in·lb	S
Cylinder Head Bolts (M10) (First)	15	1.5	11	S, M
Cylinder Head Bolts (M10) (Final)	46	4.7	34	S, M
Plug	20	2.0	15	L
Exhaust Pipe Holder Stud Bolts	25	2.5	18	
Camshaft Sprocket Bolts	9.8	1.0	87 in·lb	L
Camshaft Chain Tensioner Bolts	9.8	1.0	87 in·lb	

PERIODIC MAINTENANCE 2-7

Torque and Locking Agent

Fastener	Torque			Remarks
	N·m	kgf·m	ft·lb	
Camshaft Chain Sub-tensioner Bolt	15	1.5	11	
Camshaft Chain Guide Bolt	25	2.5	18	
Camshaft Chain Guide Retaining Plate Bolt	9.8	1.0	87 in·lb	
Muffler Body Bolts (Front and Center)	30	3.0	22	
Muffler Body Bolt (Rear)	9.8	1.0	87 in·lb	S
Muffler Body Nut	30	3.0	22	S
Muffler Cover Bolt	9.8	1.0	87 in·lb	M (1)
Clutch				
Clutch Spring Bolts	7.8	0.80	69 in·lb	
Clutch Cover Damper Plate Bolts	7.8	0.80	69 in·lb	L
Clutch Cover Bolts	9.8	1.0	87 in·lb	
Clutch Cable Holder Bracket Bolts	9.8	1.0	87 in·lb	
Right Engine Cover Bolts	9.8	1.0	87 in·lb	L (1)
Oil Seal Retaining Plate Bolt	12	1.2	106 in·lb	
Clutch Hub Nut	78	8.0	58	
Engine Lubrication System				
Oil Pump Mounting Screws	5.2	0.53	46 in·lb	
Oil Pipe Banjo Bolts (M8)	9.8	1.0	87 in·lb	
Oil Pipe Banjo Bolt (M10)	20	2.0	15	
Oil Pump Cover Screws	10	1.0	88 in·lb	
Engine Oil Drain Plug	15	1.5	11	
Oil Pressure Relief Valve	15	1.5	11	L
Engine Removal/Installation				
Upper Engine Mounting Bolt and Nut	50	5.1	37	R, S
Upper Engine Bracket Bolts	23	2.3	17	S
Lower Engine Mounting Bolt and Nut	50	5.1	37	R, S
Front Engine Mounting Bolt and Nut	50	5.1	37	R, S
Front Engine Bracket Bolts and Nuts	50	5.1	37	R, S
Swingarm Pivot Shaft Nut	88	9.0	65	S
Crankshaft/Transmission				
Crankcase Bolts	9.8	1.0	87 in·lb	
Crankcase Allen Bolts	12	1.2	106 in·lb	
Shift Drum Bearing Retaining Bolts	9.8	1.0	87 in·lb	
Shift Shaft Return Spring Pin	37	3.8	27	L
Primary Gear Nut	98	10	72	
Torque Limiter Cover Bolts	9.8	1.0	87 in·lb	
Starter Motor Clutch Bolts	12	1.2	106 in·lb	L
External Shift Mechanism Cover Screw	5.2	0.53	46 in·lb	
External Shift Mechanism Cover Bolts	9.8	1.0	87 in·lb	
Shift Pedal Bolt	9.8	1.0	87 in·lb	
Gear Positioning Lever Nut	9.8	1.0	87 in·lb	
Drive Chain Guard Plate Bolts	9.8	1.0	87 in·lb	
External Shift Mechanism Cover Nut	9.8	1.0	87 in·lb	

2-8 PERIODIC MAINTENANCE

Torque and Locking Agent

Fastener	Torque			Remarks
	N·m	kgf·m	ft·lb	
Shift Drum Cam Holder Bolt	12	1.2	106 in·lb	L
Neutral Switch	14.7	1.5	130 in·lb	G
Wheels/Tires				
Spoke Nipples	4.0	0.41	35 in·lb	
Front Axle Clamp Bolts	20	2.0	15	AL, S
Front Axle Nut	88	9.0	65	S
Rear Axle Nut	110	11.2	81.1	R
Final Drive				
Engine Sprocket Cover Bolts	9.8	1.0	87 in·lb	L (1)
Rear Sprocket Nuts	32	3.3	24	R
Engine Sprocket Nut	125	12.7	92.2	MO
Brakes				
Front Brake Light Switch Mounting Screw	1.2	0.12	11 in·lb	
Front Master Cylinder Reservoir Cap Screws	1.5	0.15	13 in·lb	
Rear Master Cylinder Reservoir Cap Screws	1.5	0.15	13 in·lb	
Brake Pad Pin Cap	2.5	0.25	22 in·lb	
Brake Lever Pivot Bolt	5.9	0.60	52 in·lb	Si
Brake Lever Pivot Bolt Locknut	5.9	0.60	52 in·lb	
Caliper Bleed Valves	7.8	0.80	69 in·lb	
Rear Master Cylinder Mounting Screws	7.8	0.80	69 in·lb	
Front Master Cylinder Clamp Bolts	8.8	0.90	78 in·lb	S
Front Caliper Brake Pad Pins	17	1.7	12	
Front Caliper Holder Shaft	17	1.7	12	Si
Rear Caliper Brake Pad Pin	17	1.7	12	
Rear Master Cylinder Push Rod Locknut	17	1.7	12	
Front Brake Disc Mounting Bolts	23	2.3	17	L
Rear Brake Disc Mounting Bolts	23	2.3	17	L
Front Caliper Mounting Bolts	25	2.5	18	
Rear Caliper Mounting Bolt	27	2.8	20	Si
Brake Hose Banjo Bolts	25	2.5	18	
Suspension				
Front Fork Cylinder Valve Assys	50	5.6	40	L
Piston Rod Nuts	15	1.5	11	
Upper Front Fork Clamp Bolts	20	2.0	15	AL
Lower Front Fork Clamp Bolts	25	2.5	18	
Front Fork Top Plugs	30	3.0	22	
Upper Rear Shock Absorber Bolt	39	4.0	29	
Lower Rear Shock Absorber Bolt	39	4.0	29	
Tie-rod Nuts	83	8.5	61	R
Swingarm Pivot Shaft Nut	88	9.0	65	
Rocker Arm Pivot Shaft Nut	98	10	72	
Steering				
Steering Stem Nut	4.9	0.50	43 in·lb	

PERIODIC MAINTENANCE 2-9

Torque and Locking Agent

Fastener	Torque			Remarks
	N·m	kgf·m	ft·lb	
Handlebar Clamp Bolts	25	2.5	18	S
Steering Stem Head Nut	44	4.5	32	
Upper Front Fork Clamp Bolts	20	2.0	15	AL
Lower Front Fork Clamp Bolts	25	2.5	18	
Left Switch Housing Screws	3.5	0.36	31 in·lb	
Right Switch Housing Screws	3.5	0.36	31 in·lb	
Frame				
Front Footpeg Bracket Bolt	39	4.0	29	
Front Footpeg Bracket Nut	39	4.0	29	R
Sidestand Nut	44	4.5	32	R
Sidestand Switch Mounting Bolt	8.8	0.90	78 in·lb	L
Electrical System				
Timing Inspection Cap	2.3	0.23	20 in·lb	
Alternator Rotor Bolt Cap	2.3	0.23	20 in·lb	
Crankshaft Sensor Screws	2.4	0.24	21 in·lb	
Starter Relay Terminal Screws	2.4	0.24	21 in·lb	
Negative Brush Assy Mounting Screw	3.8	0.39	34 in·lb	
Starter Motor Assy Bolts	5.0	0.51	44 in·lb	
ECU Bracket Screws	5.0	0.51	44 in·lb	
Stator Coil Bolts	5.9	0.60	52 in·lb	
Regulator/Rectifier Bolts	9.8	1.0	87 in·lb	
Starter Motor Cable Nut	9.8	1.0	87 in·lb	
Alternator Cover Bolts	9.8	1.0	87 in·lb	
Torque Limiter Cover Bolts	9.8	1.0	87 in·lb	
Starter Motor Mounting Bolts	9.8	1.0	87 in·lb	
Ignition Coil Mounting Bolts	9.8	1.0	87 in·lb	
Starter Motor Terminal Locknut	11	1.1	97 in·lb	
Starter Motor Clutch Bolts	12	1.2	106 in·lb	L
Spark Plug	13	1.3	115 in·lb	
Alternator Rotor Bolt	120	12.2	88.5	MO
Tail/Brake Light Lens Screws	1.0	0.10	8.8 in·lb	
Tail/Brake Light Mounting Nuts	5.9	0.60	52 in·lb	
Left Switch Housing Screws	3.5	0.36	31 in·lb	
Right Switch Housing Screws	3.5	0.36	31 in·lb	
Sidestand Switch Mounting Bolt	8.8	0.90	78 in·lb	L
Front Brake Light Switch Mounting Screw	1.2	0.12	11 in·lb	
Neutral Switch	14.7	1.5	130 in·lb	G
Engine Ground Terminal Bolt	9.8	1.0	87 in·lb	

2-10 PERIODIC MAINTENANCE

Torque and Locking Agent

The table below, relating tightening torque to thread diameter, lists the basic torque for the bolts and nuts. Use this table for only the bolts and nuts which do not require a specific torque value. All of the values are for use with dry solvent-cleaned threads.

Basic Torque for General Fasteners

Threads Diameter (mm)	Torque		
	N·m	kgf·m	ft·lb
5	3.4 ~ 4.9	0.35 ~ 0.50	30 ~ 43 in·lb
6	5.9 ~ 7.8	0.60 ~ 0.80	52 ~ 69 in·lb
8	14 ~ 19	1.4 ~ 1.9	10.0 ~ 13.5
10	25 ~ 34	2.6 ~ 3.5	19.0 ~ 25
12	44 ~ 61	4.5 ~ 6.2	33 ~ 45
14	73 ~ 98	7.4 ~ 10.0	54 ~ 72
16	115 ~ 155	11.5 ~ 16.0	83 ~ 115
18	165 ~ 225	17.0 ~ 23.0	125 ~ 165
20	225 ~ 325	23.0 ~ 33.0	165 ~ 240

Specifications

Item	Standard	Service Limit
Fuel System (DFI) Throttle Grip Free Play Idle Speed Air Cleaner Element Air Cleaner Element Oil	2 ~ 3 mm (0.08 ~ 0.12 in.) 1 300 ±50 r/min (rpm) Polyurethane Foam High quality form air filter oil	--- --- --- ---
Cooling System Coolant: Type (Recommended) Color Mixed Ratio Freezing Point Total Amount	Permanent type of antifreeze Green Soft water 50%, Coolant 50% -35°C (-31°F) 1.3 L (1.4 US qt)	--- --- --- --- ---
Engine Top End Valve Clearance: Exhaust Inlet	0.15 ~ 0.24 mm (0.0059 ~ 0.0094 in.) 0.10 ~ 0.19 mm (0.0039 ~ 0.0075 in.)	--- ---
Clutch Clutch Lever Free Play	2 ~ 3 mm (0.08 ~ 0.12 in.)	---
Engine Lubrication System Engine Oil: Type Viscosity Capacity: KLX250S9F ~ SAF/ V9F ~ VAF KLX250SBF Level	API SG, SH, SJ, SL or SM with JASO MA, MA1 or MA2 SAE 10W-40 1.3 L (1.4 US qt) (when filter is not removed) 1.4 L (1.5 US qt) (when filter is removed) 1.5 L (1.6 US qt) (when engine is completely dry) 1.0 L (1.1 US qt) (when filter is not removed) 1.1 L (1.2 US qt) (when filter is removed) 1.3 L (1.4 US qt) (when engine is completely dry) Between upper and lower level lines (Wait several minutes after idling or running)	--- --- --- --- --- --- --- ---
Wheels/Tires Tread Depth: Front: KLX250S KLX250V Rear: KLX250S KLX250V	7.8 mm (0.31 in.) 4.4 mm (0.17 in.) 11.8 mm (0.464 in.) 6.5 mm (0.26 in.)	2 mm (0.08 in.) 1 mm (0.04 in.) 2 mm (0.08 in.) 2 mm (0.08 in.) (Up to 130 km/h) 3 mm (0.12 in.) (Over 130 km/h)

2-12 PERIODIC MAINTENANCE

Specifications

Item	Standard	Service Limit
Air Pressure (When Cold):		
Front:		
KLX250S	150 kPa (1.5 kgf/cm ² , 22 psi)	---
KLX250V	200 kPa (2.0 kgf/cm ² , 29 psi)	---
Rear:		
KLX250S	Up to 97.5 kg (215 lb) load: 150 kPa (1.5 kgf/cm ² , 22 psi)	---
	97.5 ~ 181 kg (215 ~ 399 lb) load: 175 kPa (1.75 kgf/cm ² , 25 psi)	---
KLX250V	225 kPa (2.25 kgf/cm ² , 33 psi)	---
Rim Runout:		
Axial:		
KLX250S	TIR 0.7 mm (0.028 in.) or less	TIR 2.0 mm (0.08 in.)
KLX250V	TIR 0.8 mm (0.031 in.) or less	TIR 2.0 mm (0.08 in.)
Radial:		
KLX250S	TIR 1.0 mm (0.039 in.) or less	TIR 2.0 mm (0.08 in.)
KLX250V	TIR 1.2 mm (0.047 in.) or less	TIR 2.0 mm (0.08 in.)
Final Drive		
Drive Chain Slack	35 ~ 45 mm (1.4 ~ 1.8 in.)	---
Drive Chain Wear (20-link Length)	317.5 ~ 318.2 mm (12.50 ~ 12.53 in.)	323 mm (12.7 in.)
Standard Chain:		
Make	ENUMA	---
Type	EK520LV-O	---
Link:		
KLX250S	106 links	---
KLX250V	104 links	---
Brakes		
Brake Fluid:		
Grade	DOT3 or DOT4	---
Brake Pad Lining Thickness:		
Front	4.5 mm (0.18 in.)	1 mm (0.04 in.)
Rear	6.4 mm (0.25 in.)	1 mm (0.04 in.)
Brake Light Timing:		
Front	Pulled ON	---
Rear	ON after about 10 mm (0.39 in.) of pedal travel	---
Electrical System		
Spark Plug:		
Type	NGK CR8E or ND U24ESR-N	---

Special Tools

Inside Circlip Pliers:
57001-143

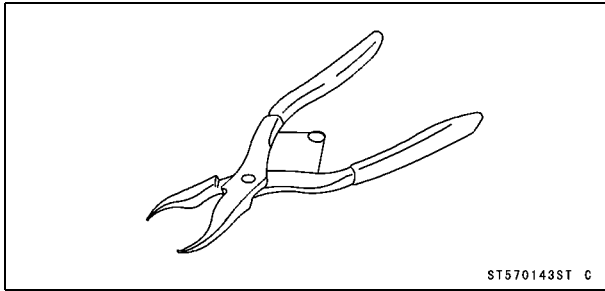

Spark Plug Wrench, Hex 16:
57001-1262

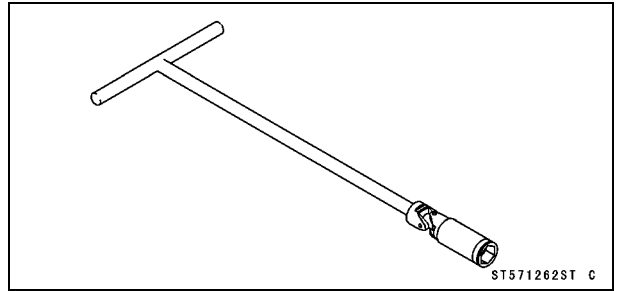

Steering Stem Nut Wrench:
57001-1100

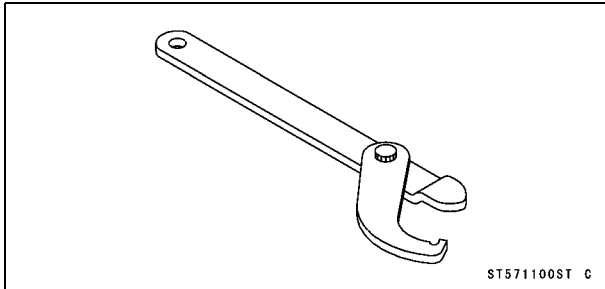

Filler Cap Driver:
57001-1454

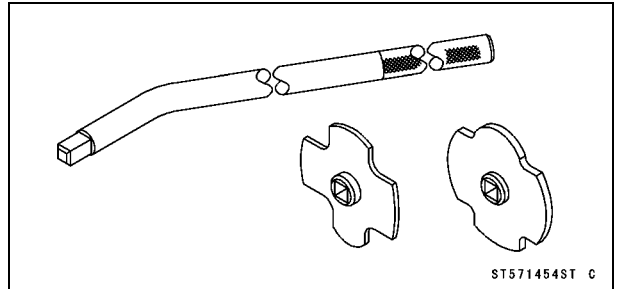

Jack:
57001-1238

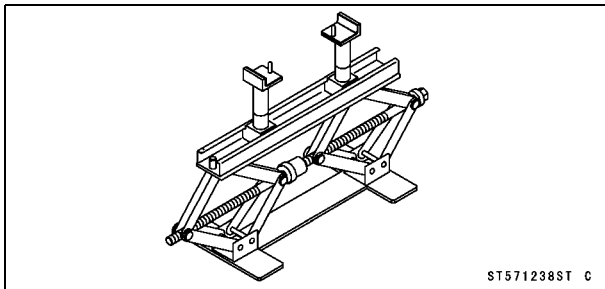

2-14 PERIODIC MAINTENANCE

Periodic Maintenance Procedures

Fuel System (DFI)

Air Cleaner Element Cleaning

NOTE

- In dusty areas, the element should be cleaned more frequently than the recommended interval.
- After riding through rain or on muddy roads, the element should be cleaned immediately.

⚠ WARNING

Gasoline and low-flash point solvents can be flammable and/or explosive and cause severe burns. Clean the element in a well-ventilated area, and take care that there is no spark or flame anywhere near the working areas. Do not use gasoline or low-flash point solvents to clean the element.

- Remove the air cleaner element (see Air Cleaner Element Replacement).
- Separate the frame [A] from the element [B].

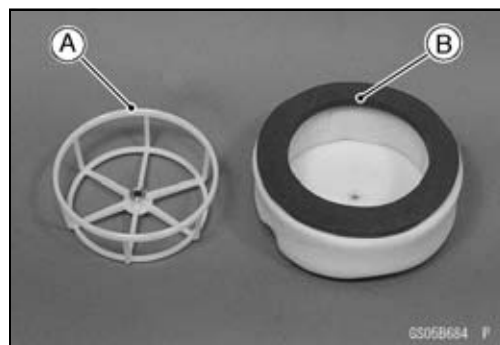

- Soak the element [A] in a bath of high-flash point solvent, and clean it by using a soft bristle brush.

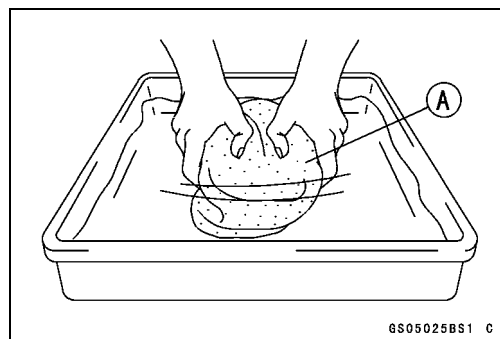

- Then squeeze it dry in a clean towel [A].

NOTICE

Do not twist or blow the element. The element can be damaged.

- Check the element and frame for visible damage.
- ★ If the element and frame are damaged, replace them.

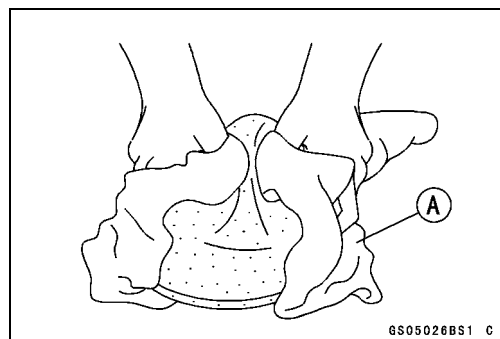

- After cleaning, saturate the element with high quality form air filter oil, and squeeze out the excess oil.
- Then wrap the element in a clean towel and squeeze it as dry as possible.
- Install the frame into the element.

Periodic Maintenance Procedures

Throttle Control System Inspection

- Check that the throttle grip [A] moves smoothly from full open to close, and the throttle closes quickly and completely by the return spring in all steering positions.
- ★ If the throttle grip does not return properly, check the throttle cable routing, grip free play, and cable damage. Then lubricate the throttle cable.
- Check the throttle grip free play [B].

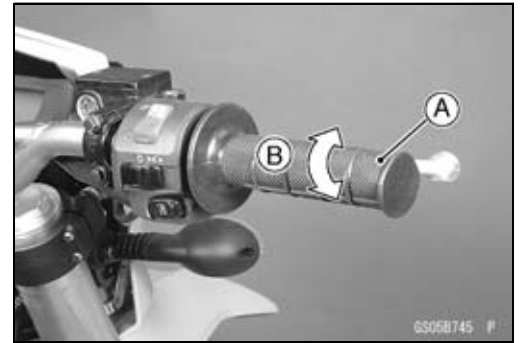

Throttle Grip Free Play

Standard: 2 ~ 3 mm (0.08 ~ 0.12 in.)

- ★ If the free play is incorrect, adjust the throttle cable as follows.
- Loosen the locknut [B] at the accelerator cable [A], screw in the adjuster [C].
- Loosen the locknut [E] at the decelerator cable [D].
- When the throttle grip full close, turn the adjuster [F] does not free play.
- Tighten the locknut.
- Turn the accelerator cable adjuster of the throttle grip free play is obtained.
- Tighten the locknut.

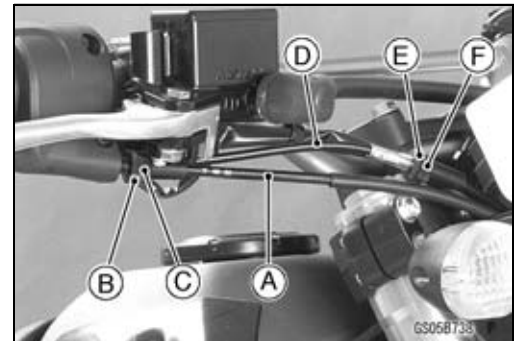

⚠ WARNING

Operation with improperly adjusted, incorrectly routed or damaged cables could result in an unsafe riding condition. Follow the service manual to be make sure to correct any of these conditions.

Idle Speed Inspection

- Start the engine and warm it up thoroughly.
- With the engine idling, turn the handlebar to both sides [A].
- ★ If handlebar movement changes the idle speed, the throttle cables may be improperly adjusted or incorrectly routed or damaged. Be sure to correct any of these conditions before riding (see Throttle Control System Inspection and Cable, Wire, and Hose Routing section in the Appendix chapter).



⚠ WARNING

Operation with improperly adjusted, incorrectly routed or damaged cables could result in an unsafe riding condition. Follow the service manual to be make sure to correct any of these conditions.

- Check the idle speed.

Idle Speed

Standard: 1 300 ±50 r/min (rpm)

- ★ If the idle speed is out of the specified range, adjust it.

2-16 PERIODIC MAINTENANCE

Periodic Maintenance Procedures

Idle Speed Adjustment

- Start the engine and warm it up thoroughly.
- Turn the adjusting screw [A] until the idle speed is correct.
- Open and close the throttle a few times to make sure that the idle speed is within the specified range. Readjust if necessary.

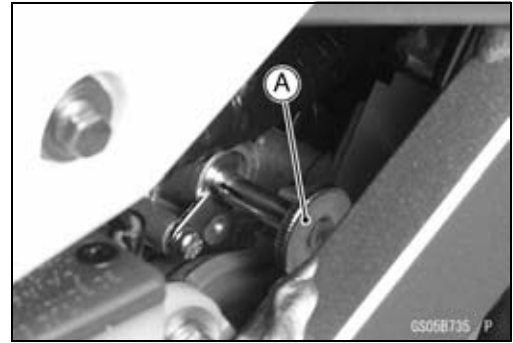

Fuel Hose Inspection (fuel leak, damage, installation condition)

- If the motorcycle is not properly handled, the high pressure inside the fuel line can cause fuel to leak [A] or the hose burst.
- ★ Replace the fuel hose if any fraying, cracks [B] or bulges [C] are noticed.
- Check that the fuel hose is routed according to Cable, Wire, and Hose Routing section in the Appendix chapter.
- When installing the fuel hose, avoid sharp bending, kinking, flattening or twist, and route the fuel hose with a minimum of bending so that fuel flow will not be obstructed.
- ★ Replace the hose if it has been sharply bent or kinked.

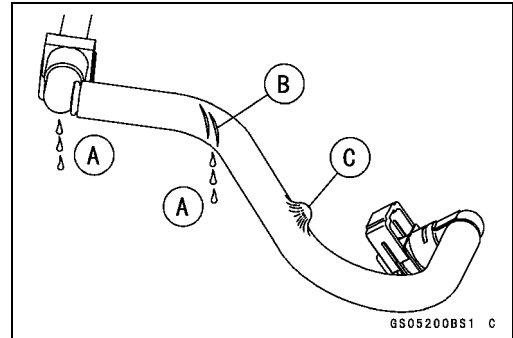

Evaporative Emission Control System Inspection (SEA and TH Models)

- Inspect the canister as follows.
- Remove the left side cover (see Side Cover Removal in the Frame chapter).
- Remove the canister [A], and disconnect the hoses from the canister.
- Visually inspect the canister for cracks or other damage.
- ★ If the canister has any cracks or bad damage, replace it with a new one.



NOTE

- *The canister is designed to work well through the motorcycle's life without any maintenance if it is used under normal conditions.*

Periodic Maintenance Procedures

- Check the liquid/vapor separator as follows.
 - Disconnect the hoses from the separator, and remove the separator [A] from the motorcycle left side.
 - Visually inspect the separator for cracks and other damage.
 - ★ If the separator has any cracks or damage, replace it with a new one.
 - To prevent the gasoline from flowing into or out of the canister, hold the separator perpendicular to the ground.
- Check the hoses of the evaporative emission control system as follows.
 - Check that the hoses are securely connected and clips are in position.
 - Replace any kinked, deteriorated or damaged hoses.
 - Route the hoses according to Cable, Wire, and Hose Routing section in the Appendix chapter.
 - When installing the hoses, avoid sharp bending, kinking, flattening or twisting, and route the hoses with a minimum of bending so that the emission flow will not be obstructed.

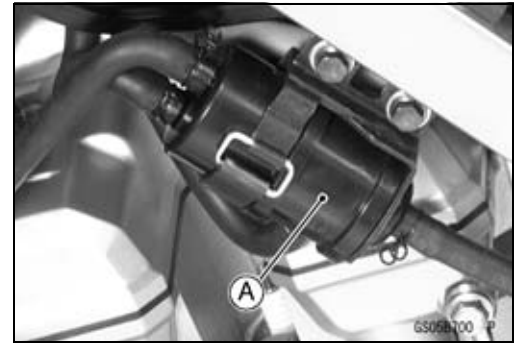

Cooling System

Coolant Level Inspection

NOTE

- Check the level when the engine is cold (room or ambient temperature).
- Check the coolant level in the reserve tank [A] with the motorcycle held perpendicular (Do not use the side-stand.).
- ★ If the coolant level is lower than the “LOW” level line [B], unscrew the reserve tank cap and add coolant to the “FULL” level line [C].

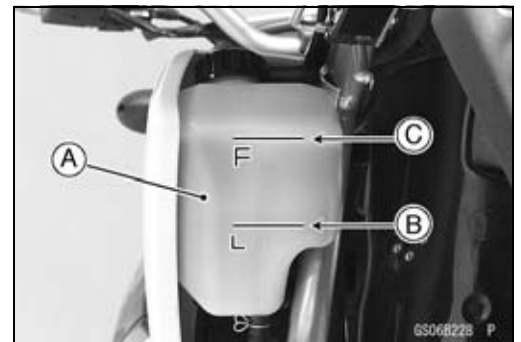

NOTICE

For refilling, add the specified mixture of coolant and soft water. Adding water alone dilutes the coolant and degrades its anticorrosion properties. The diluted coolant can attack the aluminum engine parts. In an emergency, soft water alone can be added. But the diluted coolant must be returned to the correct mixture ratio within a few days. If coolant must be added often or the reservoir tank has run completely dry, there is probably leakage in the cooling system. Check the system for leaks. Coolant ruins painted surfaces. Immediately wash away any coolant that spills on the frame, engine, wheels or other painted parts.

2-18 PERIODIC MAINTENANCE

Periodic Maintenance Procedures

Radiator Hose Inspection (coolant leak, damage, installation condition)

- The high pressure inside the radiator hose can cause coolant to leak [A] or the hose to burst if the line is not properly maintained.
- Visually inspect the hoses for signs of deterioration. Squeeze the hoses. A hose should not be hard and brittle, nor should it be soft or swollen.
- ★Replace the hose if any fraying, cracks [B] or bulges [C] are noticed.
- Check that the hoses are securely connected and water hose clamp screws are tightened correctly.

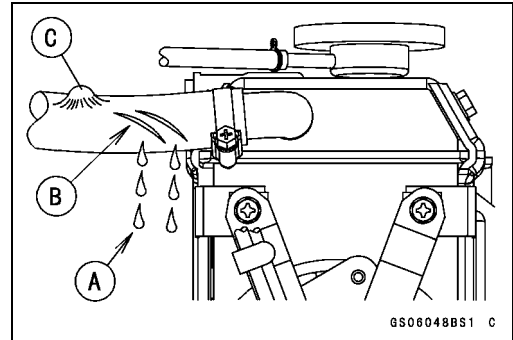

Engine Top End

Valve Clearance Inspection

NOTE

○Valve clearance must be checked and adjusted when the engine is cold (room temperature).

- Remove the cylinder head cover (see Cylinder Head Cover Removal in the Engine Top End chapter).
- Remove the timing inspection cap [A] and alternator rotor bolt cap [B], using the filler cap driver.

Special Tool - Filler Cap Driver: 57001-1454

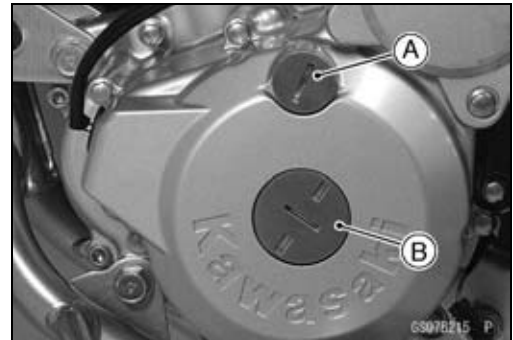

- Using a wrench on the alternator rotor bolt, turn the crankshaft counterclockwise [A] until the "T" mark [B] on the alternator rotor is aligned with notch [C] in the edge of the timing inspection hole.

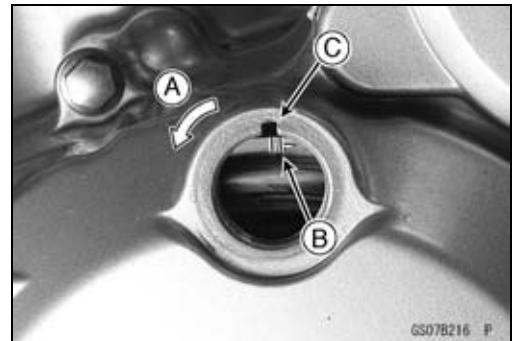

- Using the thickness gauge [A], measure the valve clearance between cam and shim of all four valves.
- Measure the valve clearance of the valves for which the cam [B] are turned away from each other.

Valve Clearance

Standard:

Exhaust	0.15 ~ 0.24 mm (0.0059 ~ 0.0094 in.)
Inlet	0.10 ~ 0.19 mm (0.0039 ~ 0.0075 in.)

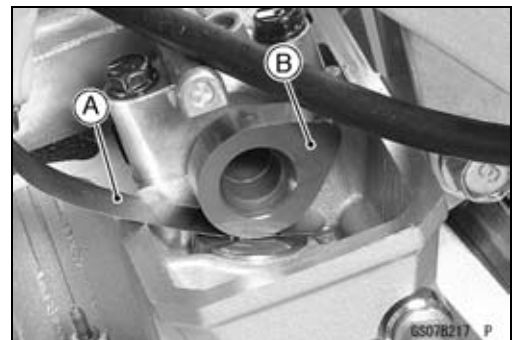

NOTE

○Check the valve clearance using this method only. Checking the clearance at any other cam position may result in improper valve clearance.

- ★If the valve clearance is not within the specified range, first record the clearance, and then adjust it.

Periodic Maintenance Procedures

Valve Clearance Adjustment

- Remove the camshaft [A] (see Camshaft Removal in the Engine Top End chapter).
- Remove the valve lifter [B] of a valve that requires an adjustment.
- Remove the shim [C] on the spring retainer.

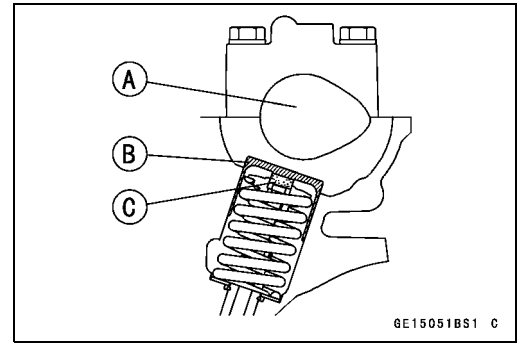

NOTE

○Mark the shim and valve lifter so that they can be installed in their original positions during assembly.

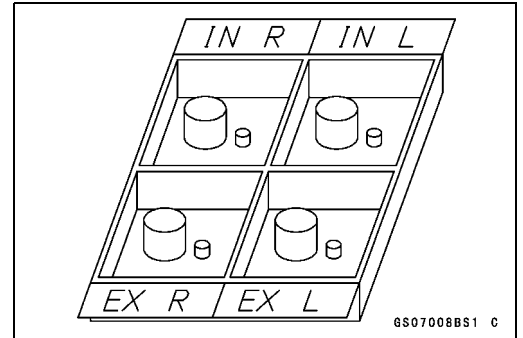

- Measure the thickness of the removed shim.
- Select an optimum shim from the Valve Clearance Adjustment Charts and replace the shim detached from the motorcycle with the selected one.

NOTE

○If there is no valve clearance, use a shim that is a few sizes smaller, and remeasure the valve clearance.

- Apply engine oil to the shim and install it so that the mark [A] on it faces to the valve lifter [B].

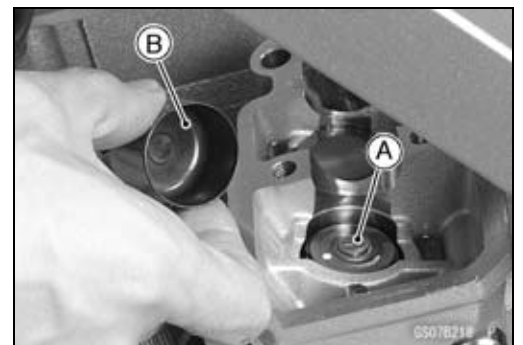

NOTICE

Do not put shim stock under the shim. This may cause the shim to pop out at high rpm, causing extensive engine damage.
Do not grind the shim. This may cause it to fracture, causing extensive engine damage.

- Apply oil to the valve lifter surface, and install it.
- Install the camshaft (see Camshaft Installation in the Engine Top End chapter).
- Recheck the valve clearance and readjust if necessary.
- Install the cylinder head cover, timing inspection cap and rotor bolt cap.

Special Tool - Filler Cap Driver: 57001-1454

Torque - Timing Inspection Cap: 2.3 N·m (0.23 kgf·m, 20 in·lb)

Alternator Rotor Bolt Cap: 2.3 N·m (0.23 kgf·m, 20 in·lb)

2-20 PERIODIC MAINTENANCE

Periodic Maintenance Procedures

Valve Clearance Adjustment Charts Inlet

		Present Shim														Example						
Part No. (92180~)		1014	1016	1018	1020	1022	1024	1026	1028	1030	1032	1034	1036	1038	1040	1042	1044	1046	1048	1050	1052	1054
Mark		50	55	60	65	70	75	80	85	90	95	00	05	10	15	20	25	30	35	40	45	50
Thickness (mm)		2.50	2.55	2.60	2.65	2.70	2.75	2.80	2.85	2.90	2.95	3.00	3.05	3.10	3.15	3.20	3.25	3.30	3.35	3.40	3.45	3.50
Valve Clearance Measurement (mm)	0.00~0.04	-	-	-	2.50	2.55	2.60	2.65	2.70	2.75	2.80	2.85	2.90	2.95	3.00	3.05	3.10	3.15	3.20	3.25	3.30	3.35
	0.05~0.09	-	-	2.50	2.55	2.60	2.65	2.70	2.75	2.80	2.85	2.90	2.95	3.00	3.05	3.10	3.15	3.20	3.25	3.30	3.35	3.40
	0.10~0.14	Specified Clearance / No Change Required																				
	0.15~0.19	Specified Clearance / No Change Required																				
	0.20~0.24	2.55	2.60	2.65	2.70	2.75	2.80	2.85	2.90	2.95	3.00	3.05	3.10	3.15	3.20	3.25	3.30	3.35	3.40	3.45	3.50	
	0.25~0.29	2.60	2.65	2.70	2.75	2.80	2.85	2.90	2.95	3.00	3.05	3.10	3.15	3.20	3.25	3.30	3.35	3.40	3.45	3.50		
	0.30~0.34	2.65	2.70	2.75	2.80	2.85	2.90	2.95	3.00	3.05	3.10	3.15	3.20	3.25	3.30	3.35	3.40	3.45	3.50			
	0.35~0.39	2.70	2.75	2.80	2.85	2.90	2.95	3.00	3.05	3.10	3.15	3.20	3.25	3.30	3.35	3.40	3.45	3.50				
	0.40~0.44	2.75	2.80	2.85	2.90	2.95	3.00	3.05	3.10	3.15	3.20	3.25	3.30	3.35	3.40	3.45	3.50					
	0.45~0.49	2.80	2.85	2.90	2.95	3.00	3.05	3.10	3.15	3.20	3.25	3.30	3.35	3.40	3.45	3.50						
	0.50~0.54	2.85	2.90	2.95	3.00	3.05	3.10	3.15	3.20	3.25	3.30	3.35	3.40	3.45	3.50							
	0.55~0.59	2.90	2.95	3.00	3.05	3.10	3.15	3.20	3.25	3.30	3.35	3.40	3.45	3.50								
	0.60~0.64	2.95	3.00	3.05	3.10	3.15	3.20	3.25	3.30	3.35	3.40	3.45	3.50									
	0.65~0.69	3.00	3.05	3.10	3.15	3.20	3.25	3.30	3.35	3.40	3.45	3.50										
	0.70~0.74	3.05	3.10	3.15	3.20	3.25	3.30	3.35	3.40	3.45	3.50											
0.75~0.79	3.10	3.15	3.20	3.25	3.30	3.35	3.40	3.45	3.50													
0.80~0.84	3.15	3.20	3.25	3.30	3.35	3.40	3.45	3.50														
0.85~0.89	3.20	3.25	3.30	3.35	3.40	3.45	3.50															
0.90~0.94	3.25	3.30	3.35	3.40	3.45	3.50																
0.95~0.99	3.30	3.35	3.40	3.45	3.50																	
1.00~1.04	3.35	3.40	3.45	3.50																		
1.05~1.09	3.40	3.45	3.50																			
1.10~1.14	3.45	3.50																				
1.15~1.19	3.50																					

Install the shim of this thickness (mm)

GE15162B S

1. Measure the valve clearance (when cold).
2. Check the present shim size.
3. Select an optimum shim based on a measured clearance value (row headings) and the thickness of the shim currently in use (column headings).
4. The cell where the row and line intersect indicates the shim thickness that provides a standard clearance.

(Example) Present Shim: 2.95 mm
 Measured clearance: 0.36 mm
 Exchange the shim for the 3.15 mm size shim. (intersecting point)

- Apply engine oil to the valve lifter surface and install the lifter.
- Install the camshafts.
- Recheck the valve clearance and readjust if necessary.

NOTE

○If the valve clearance is smaller (larger) than the standard, select a thinner (thicker) shim.

Periodic Maintenance Procedures

Valve Clearance Adjustment Charts
Exhaust

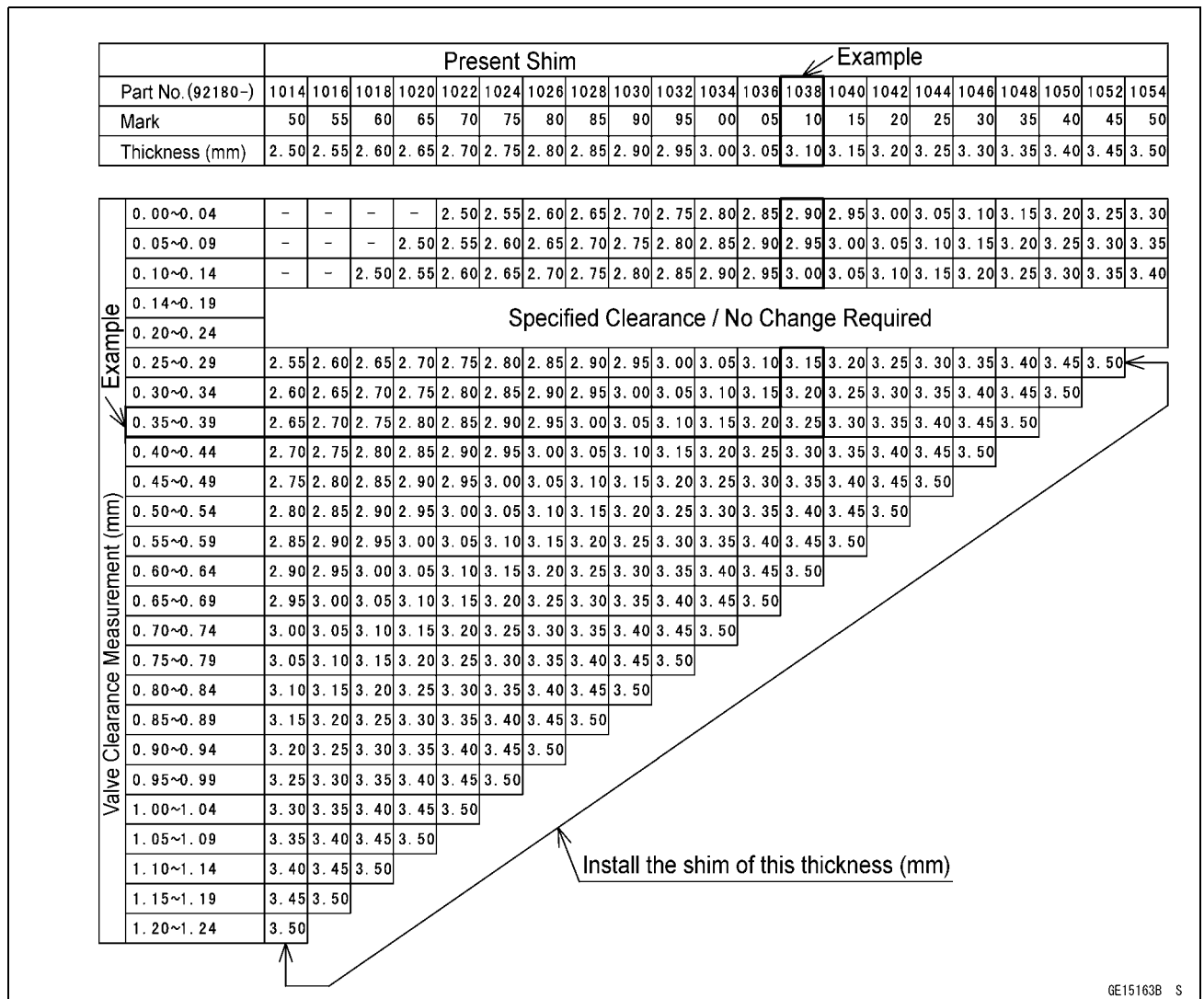

1. Measure the valve clearance (when cold).
2. Check the present shim size.
3. Select an optimum shim based on a measured clearance value (row headings) and the thickness of the shim currently in use (column headings).
4. The cell where the row and line intersect indicates the shim thickness that provides a standard clearance.

(Example) Present Shim: 3.10 mm
 Measured clearance: 0.36 mm
 Exchange the shim for the 3.25 mm size shim. (intersecting point)

- Apply engine oil to the valve lifter surface and install the lifter.
- Install the camshafts.
- Recheck the valve clearance and readjust if necessary.

NOTE

If the valve clearance is smaller (larger) than the standard, select a thinner (thicker) shim.

2-22 PERIODIC MAINTENANCE

Periodic Maintenance Procedures

Air Suction System Damage Inspection

- Remove the fuel tank (see Fuel Tank Removal in the Fuel System (DFI) chapter).
- Separate the air switching valve hose [A] from the air cleaner housing.

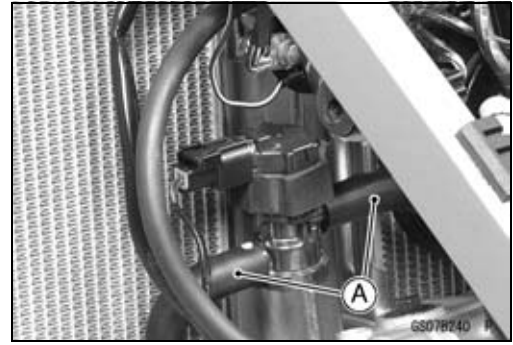

- Install the fuel tank temporary (see Fuel Tank Installation in the Fuel System (DFI) chapter).
- Start the engine and run it at idle speed.
- Plug the air switching valve hose end [A] with your finger and feel vacuum pulsing in the hose.
- ★ If there is no vacuum pulsation, check the hose line for leak.
- ★ If there is no leak, check the air switching valve (see Air Switching Valve Test in the Engine Top End chapter).

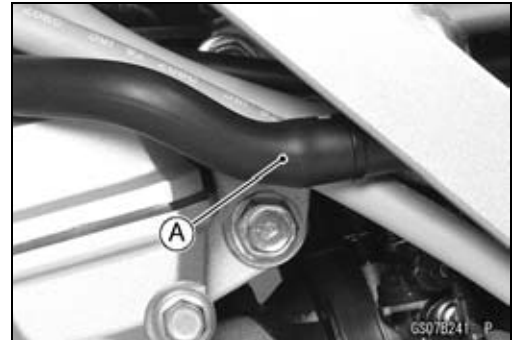

Clutch

Clutch Operation Inspection

- Turn over the dust cover [A].
- Pull the clutch lever [B] lightly, and check the clutch lever free play [C].

Clutch Lever Free Play

Standard: 2 ~ 3 mm (0.08 ~ 0.12 in.)

- ★ If the free play is incorrect, adjust it.

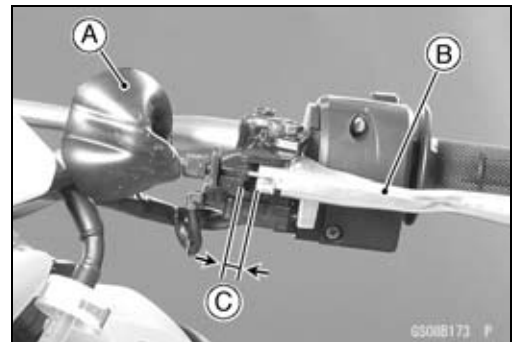

- Loosen the locknut [A].
- Turn the adjuster [B] to adjust the free play.
- Tighten the locknut.
- Slide back the dust cover.
- ★ If the free play can not be adjusted with the adjuster at the clutch lever, use the adjuster at the middle of the clutch cable.

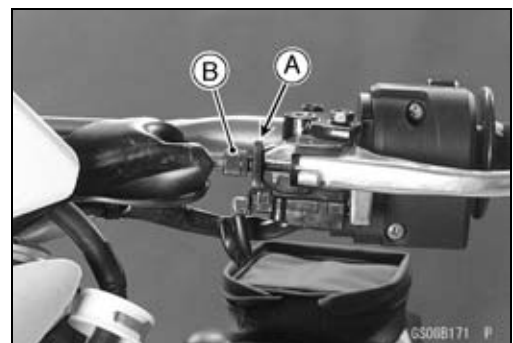

Periodic Maintenance Procedures

⚠ WARNING

The engine and exhaust system get extremely hot during normal operation and can cause serious burns. Never touch the engine or exhaust pipe during clutch adjustment.

- Slide the dust cover [A] at the clutch cable.
- Loosen the locknut [B] at the middle of the clutch cable.
- Turn the adjuster [C] at the clutch cable until the free play is correct.
- Slide back the dust cover.
- After the adjustment, start the engine and check that the clutch does not slip and that it releases properly.

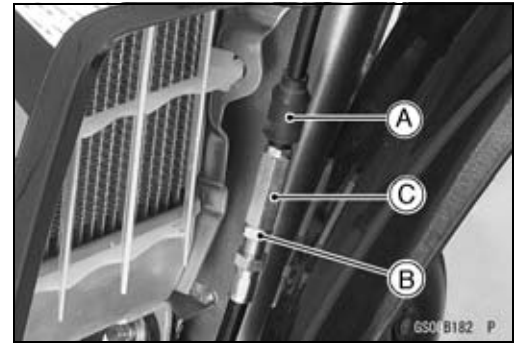

⚠ WARNING

When test riding the motorcycle, be aware of surrounding traffic for your safety.

Wheels/Tires

Air Pressure Inspection

- Remove the air valve cap.
- Measure the tire air pressure with an air pressure gauge [A] when the tires are cold (that is, when the motorcycle has not been ridden more than a mile during the past 3 hours).
- Install the air valve cap.
- ★ Adjust the tire air pressure according to the specifications if necessary.

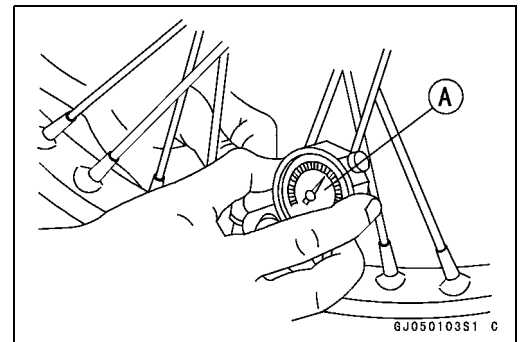

Air Pressure (When Cold)

Front:

KLX250S	150 kPa (1.5 kgf/cm², 22 psi)
KLX250V	200 kPa (2.0 kgf/cm², 29 psi)

Rear:

KLX250S	Up to 97.5 kg (215 lb)
	150 kPa (1.5 kgf/cm², 22 psi)
	97.5 ~ 181 kg (215 ~ 399 lb)
	175 kPa (1.75 kgf/cm², 25 psi)
KLX250V	225 kPa (2.25 kgf/cm², 33 psi)

Wheel/Tire Damage Inspection

- Remove any imbedded stones [A] or other foreign particles [B] from tread.
- Visually inspect the tire for cracks [C] and cuts [D], and replace the tire if necessary. Swelling or high spots indicate internal damage, requiring tire replacement.
- Visually inspect the wheel for cracks, cuts and dents damage.
- ★ If any damage is found, replace the wheel if necessary.

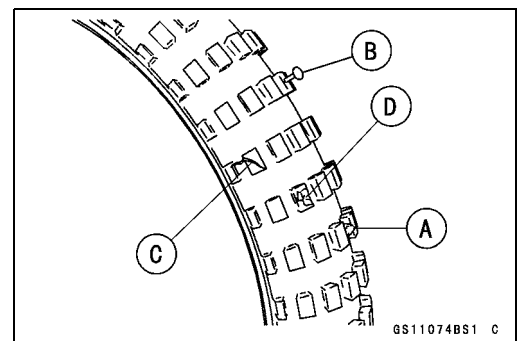

2-24 PERIODIC MAINTENANCE

Periodic Maintenance Procedures

Tire Tread Wear Inspection

As the tire tread wears down, the tire becomes more susceptible to puncture and failure. An accepted estimate is that 90% of all tire failures occur during the last 10% of tread life (90% worn). So it is false economy and unsafe to use the tires until they are bald.

- Measure the tread depth at the center of the tread with a depth gauge [A]. Since the tire may wear unevenly, take measurement at several places.
- ★ If any measurement is less than the service limit, replace the tire (see Tire Removal/Installation in the Wheels/Tires chapter).

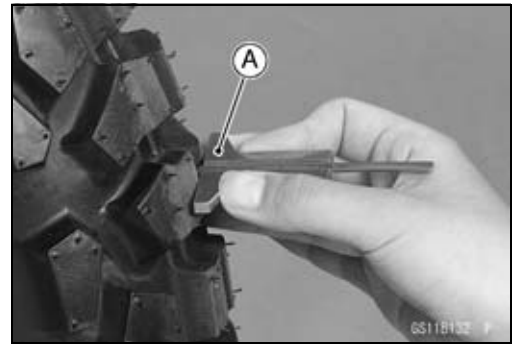

Tread Depth

Standard:

Front:

KLX250S 7.8 mm (0.31 in.)

KLX250V 4.4 mm (0.17 in.)

Rear:

KLX250S 11.8 mm (0.464 in.)

KLX250V 6.5 mm (0.26 in.)

Service Limit:

Front:

KLX250S 2 mm (0.08 in.)

KLX250V 1 mm (0.04 in.)

Rear:

KLX250S 2 mm (0.08 in.)

KLX250V 2 mm (0.08 in.) (Up to 130 km/h)

3 mm (0.12 in.) (Over 130 km/h)

⚠ WARNING

Some replacement tires may adversely affect handling and cause an accident resulting in serious injury or death. To ensure proper handling and stability, use only the recommended standard tires for replacement, inflated to the standard pressure.

Wheel Bearing Damage Inspection

- Raise the front wheel off the ground with jack.
Special Tool - Jack: 57001-1238
- Turn the handlebar all the way to the right or left.
- Inspect the roughness of the front wheel bearing by moving [A] the wheel with both hands to both sides.
- Spin [B] the front wheel lightly, and check for smoothly turn, roughness, binding or noise.
- ★ If roughness, binding or noise is found, remove the front wheel and inspect the wheel bearing (see Front Wheel Removal, Hub Bearing Inspection in the Wheels/Tires chapter).



Periodic Maintenance Procedures

- Raise the rear wheel off the ground with jack.
- Special Tool - Jack: 57001-1238**
- Inspect the roughness of the rear wheel bearing by moving the wheel with both hands to both sides.
- Spin [A] the rear wheel lightly, and check for smoothly turn, roughness, binding or noise.
- ★ If roughness, binding or noise is found, remove the rear wheel and inspect the wheel bearing (see Rear Wheel Removal, Hub Bearing Inspection in the Wheels/Tires chapter).



Spoke Tightness and Rim Runout Inspection

- Check that all the spokes are tightened evenly.
- ★ If spoke tightness is uneven or loose, tighten the spoke nipples evenly.

Torque - Spoke Nipples: 4.0 N·m (0.41 kgf·m, 35 in·lb)

- Check the rim runout.

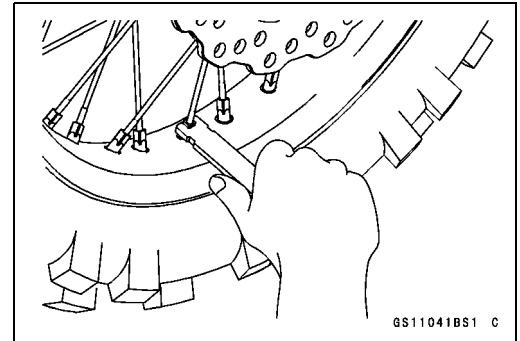

⚠ WARNING

A missing spoke places an additional load on the other spokes, which will eventually cause other spokes to break, creating the potential for an accident resulting in serious injury or death. Immediately replace any broken spoke(s).

2-26 PERIODIC MAINTENANCE

Periodic Maintenance Procedures

- Raise the front/rear wheel off the ground with jack.
Special Tool - Jack: 57001-1238
- Inspect the rim for small cracks, dents, bending, or warping.
- ★ If there is any damage to the rim, it must be replaced.
- Set a dial gauge against the side of the rim, and rotate the rim to measure the axial runout [A]. The difference between the highest and lowest dial readings is the amount of runout.
- Set a dial gauge against the outer circumference of the rim, and rotate the rim to measure radial runout [B]. The difference between the highest and lowest dial readings is the amount of runout.
- ★ If rim runout exceeds the service limit, check the wheel bearings first. Replace them if they are damaged. If the problem is not due to the bearings, correct the rim warp (runout). A certain amount of rim warp can be corrected by recentering the rim. Loosen some spokes and tighten others within the standard torque to change the position of different parts of the rim. If the rim is badly bent, however, it must be replaced.

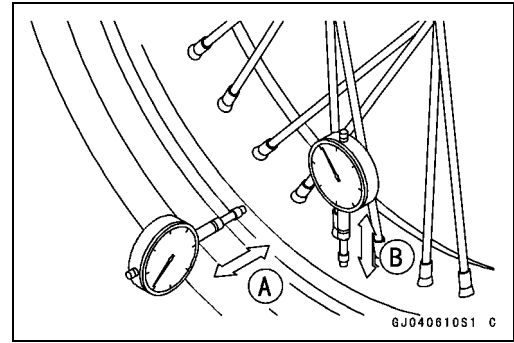

Rim Runout (with tire installed)

Standard:

Axial:

KLX250S TIR 0.7 mm (0.028 in.) or less

KLX250V TIR 0.8 mm (0.031 in.) or less

Radial:

KLX250S TIR 1.0 mm (0.039 in.) or less

KLX250V TIR 1.2 mm (0.047 in.) or less

Service Limit:

Axial: TIR 2.0 mm (0.08 in.)

Radial: TIR 2.0 mm (0.08 in.)

Drive Train

Drive Chain Lubrication Condition Inspection

- If a special lubricant is not available, a heavy oil such as SAE 90 is preferred to a lighter oil because it will stay on the chain longer and provide better lubrication.
- If the chain appears especially dirty, clean it before lubrication.

NOTICE

The O-rings between the side plates seal in the lubricant between the pin and the bushing. To avoid damaging the O-rings and resultant loss of lubricant, observe the following rules.

Use only kerosene or diesel oil for cleaning of the O-ring of the drive chain. Any other cleaning solution such as gasoline or trichloroethylene will cause deterioration and swelling of the O-ring. Immediately blow the chain dry with compressed air after cleaning. Complete cleaning and drying the chain within 10 minutes.

Periodic Maintenance Procedures

- Apply oil to the sides of the rollers so that oil will penetrate to the rollers and bushings. Apply the oil to the O-rings so that the O-rings will be coated with oil.
- Wipe off any excess oil.
 - Oil Applied Areas [A]
 - O-rings [B]

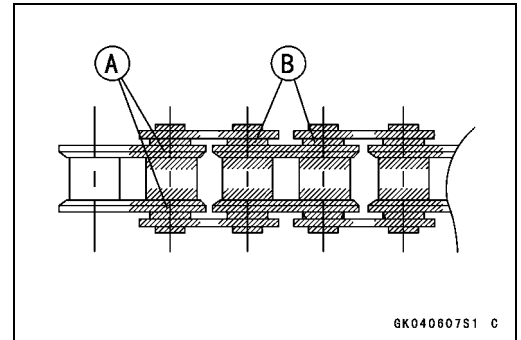

Drive Chain Slack Inspection

NOTE

- Check the slack with the motorcycle setting on its side-stand.
- Clean the chain if it is dirty, and lubricate it if it appears dry.
- Check the wheel alignment (see Wheel Alignment Inspection).
- Rotate the rear wheel to find the position where the chain is tightest.
- Measure the vertical movement (chain slack) [A] midway between the sprockets.
- ★ If the chain slack exceeds the standard, adjust it.

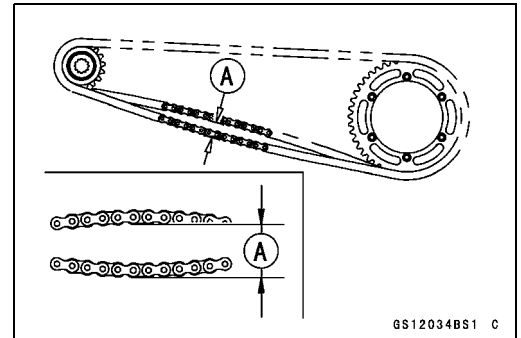

Chain Slack

Standard: 35 ~ 45 mm (1.4 ~ 1.8 in.)

Drive Chain Slack Adjustment

- Remove the cotter pin [A], and loosen the axle nut [B].
- Loosen the both chain adjuster locknuts [C].
- ★ If the chain is too loose, turn out the right and left chain adjusters [D] evenly.
- ★ If the chain is too tight, turn in the right and left chain adjusters evenly, and kick the wheel forward.
- Turn both chain adjusters evenly until the drive chain has the correct amount of slack. To keep the chain and wheel properly aligned, the notch [E] on the right wheel alignment indicator [F] should align with the same swingarm mark or position [G] that the left indicator notch aligns with.

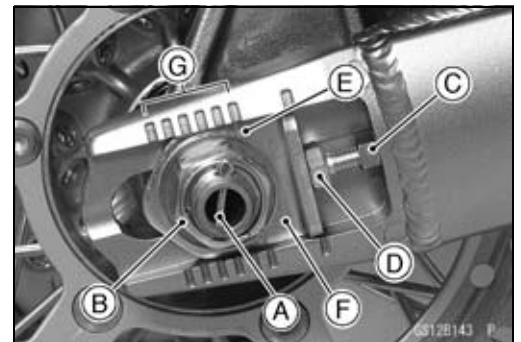

⚠ WARNING

Misalignment of the wheel will result in abnormal wear and may result in an unsafe riding condition. Be sure the wheel is properly aligned.

- Tighten both chain adjuster locknuts securely.
- Tighten the axle nut.
 - Torque - Rear Axle Nut: 110 N·m (11.2 kgf·m, 81.1 ft·lb)**
- Turn the wheel, measure the chain slack again at the tightest position, and readjust if necessary.
- Replace the cotter pin with a new one. Insert the cotter pin to the axle shaft and spread its ends surely.

2-28 PERIODIC MAINTENANCE

Periodic Maintenance Procedures

NOTE

- When inserting the cotter pin, if the slots in the nut do not align with the cotter pin hole in the axle shaft, tighten the nut clockwise [A] up to next alignment.
- It should be within 30 degree.
- Loosen one and tighten again when the slot goes past the nearest hole.

WARNING

A loose axle nut can lead to an accident resulting in serious injury or death. Tighten the axle nut to the proper torque and install a new cotter pin.

Wheel Alignment Inspection

- Check that the notch [A] on the right alignment indicator [B] aligns with the same swingarm mark or position [C] that the left alignment indicator notch aligns with.
- ★ If they do not, adjust the chain slack and align the wheel alignment (see Drive Chain Slack Adjustment).

NOTE

- Wheel alignment can be also checked using the straightedge or string method.

WARNING

Misalignment of the wheel will result in abnormal wear and may result in an unsafe riding condition. Tighten both belt adjuster locknuts.

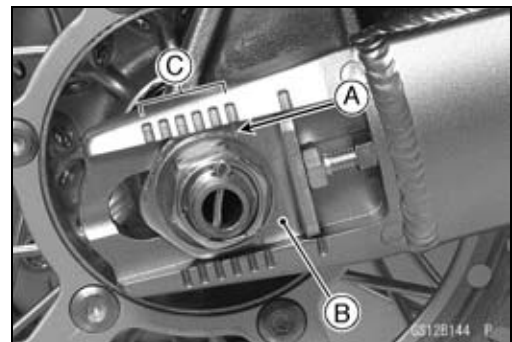
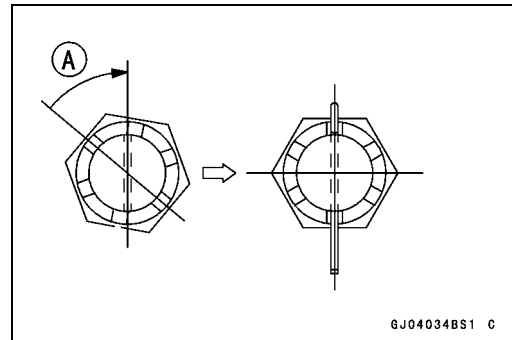

Periodic Maintenance Procedures

Drive Chain Wear Inspection

- Remove the chain cover (see Drive Chain Removal in the Final Drive chapter).
- Rotate the rear wheel to inspect the drive chain for damaged rollers, and loose pins and links.
- ★ If there is any irregularity, replace the drive chain.
- ★ Lubricate the drive chain if it appears dry.
- Stretch the chain taut by hanging a 98 N (10 kg, 20 lb) weight [A] on the chain.
- Measure the length of 20 links [B] on the straight part [C] of the chain from the pin center of the 1st pin to the pin center of the 21st pin. Since the chain may wear unevenly, take measurements at several places.
- ★ If any measurements exceed the service limit, replace the chain. Also, replace the front and rear sprockets when the drive chain is replaced.

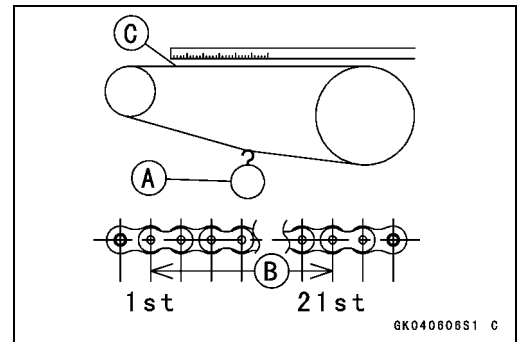

Drive Chain 20-link Length

Standard: 317.5 ~ 318.2 mm (12.50 ~ 12.53 in.)

Service Limit: 323 mm (12.7 in.)

⚠ WARNING

A chain that breaks or jumps off the sprockets could snag on the engine sprocket or lock the rear wheel, severely damaging the motorcycle and causing it to go out of control. Inspect the chain for damage and proper adjustment before each ride. If chain wear exceeds the service limit, replace it with the standard chain. It is an endless type and should not be cut for installation.

Standard Chain

- Make:** ENUMA
- Type:** EK525LV-O
- Link:**
 - KLX250S 106 Links
 - KLX250V 104 Links

2-30 PERIODIC MAINTENANCE

Periodic Maintenance Procedures

Chain Guide Wear Inspection

- Visually inspect the following parts.
 - Front Chain Guide [A]
 - Rear Chain Guide [B]
 - Chain Slipper [C]
 - Chain Guide Roller [D]
- ★ If the chain guides, chain slipper and chain guide roller show any signs of abnormal wear or damage, replace them.

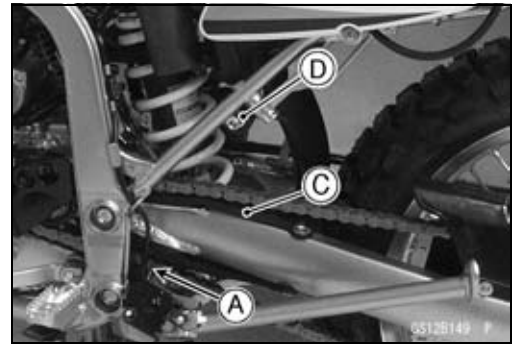

Periodic Maintenance Procedures

Brake System

Brake Fluid Leak Inspection

- Apply the brake lever or pedal and inspect the brake fluid leak from the brake hoses [A] and fittings [B].
- ★ If the brake fluid leaked from any position, inspect or replace the problem part.

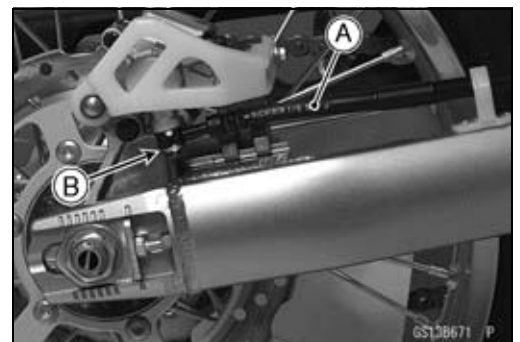
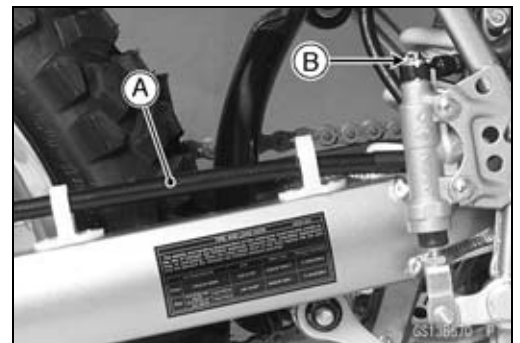
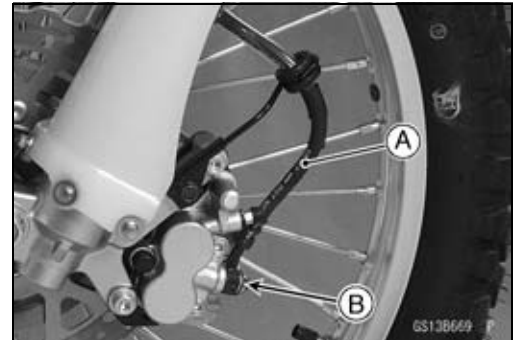
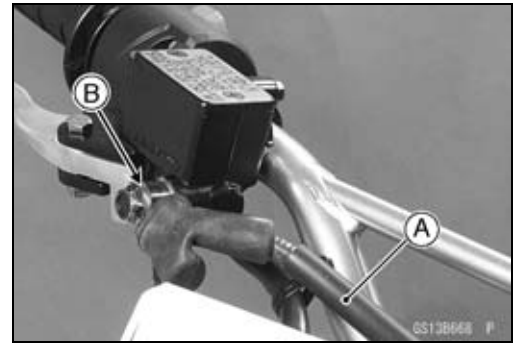

2-32 PERIODIC MAINTENANCE

Periodic Maintenance Procedures

Brake Hose Damage and Installation Condition Inspection

- Inspect the brake hoses and fittings for deterioration, cracks and signs of leakage.
- The high pressure inside the brake line can cause fluid to leak [A] or the hose to burst if the line is not properly maintained. Bend and twist the rubber hose while examining it.
- ★ Replace the hose if any crack [B], bulge [C] or leakage is noticed.
- ★ Tighten any brake hose banjo bolts and brake pipe joint nuts.

Torque - Brake Hose Banjo Bolts: 25 N·m (2.5 kgf·m, 18 ft·lb)

- Inspect the brake hose routing.
- ★ If any brake hose routing is incorrect, route the brake hose according to Cable, Wire, and Hose Routing section in the Appendix chapter.

Brake Operation Inspection

- Inspect the operation of the front and rear brake by running the vehicle on the dry road.
- ★ If the brake operation is insufficiency, inspect the brake system.

⚠ WARNING

When test riding the vehicle, be aware of surrounding traffic for your safety.

Brake Fluid Level Inspection

- Check that the brake fluid level in the front brake reservoir [A] is above the lower level line [B].

NOTE

○ Hold the reservoir horizontal by turning the handlebar when checking brake fluid level.

- ★ If the fluid level is lower than the lower level line, fill the reservoir to the upper level line [A] in the reservoir.
- Install the front master cylinder reservoir cap.

Torque - Front Master Cylinder Reservoir Cap Screws: 1.5 N·m (0.15 kgf·m, 13 in·lb)

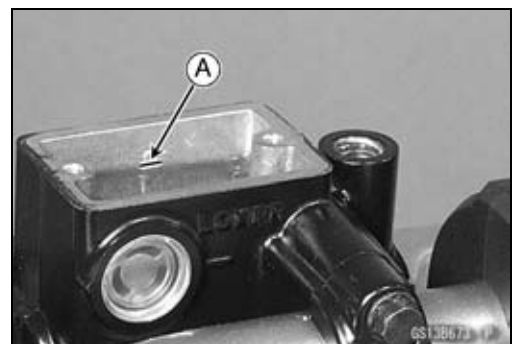
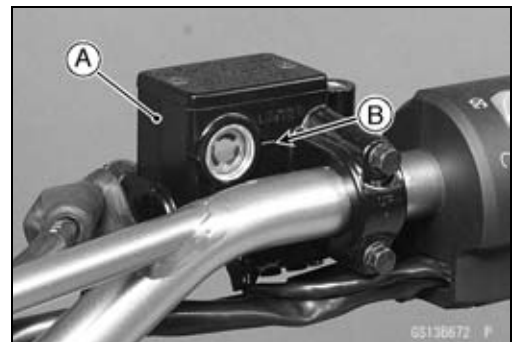
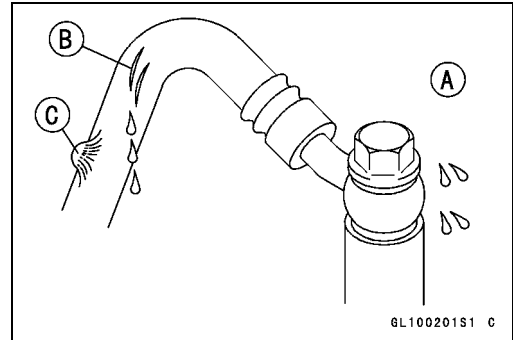

Periodic Maintenance Procedures

- Check that the brake fluid level in the rear brake reservoir [A] is above the lower level line [B].
- ★ If the fluid level is lower than the lower level line, fill the reservoir to the upper level line [C].

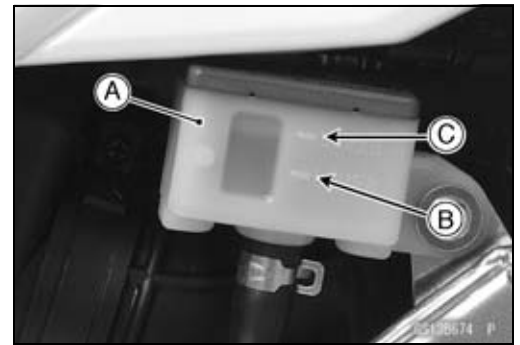

⚠ WARNING

Mixing brands and types of brake fluid can reduce the brake system's effectiveness and cause an accident resulting in injury or death. Do not mix two brands of brake fluid. Change the brake fluid in the brake line completely if the brake fluid must be re-filled but the type and brand of the brake fluid that is already in the reservoir are unidentified.

Recommended Disc Brake Fluid
Grade: DOT3 or DOT4

- Install the rear master cylinder reservoir cap.
Torque - Rear Master Cylinder Reservoir Cap Screws: 1.5 N·m (0.15 kgf·m, 13 in·lb)

Brake Pad Wear Inspection

- Remove the brake pads (see Front/Rear Brake Pad Removal in the Brakes chapter).
- Check the lining thickness [A] of the pads in each caliper.
- ★ If the lining thickness of either pad is less than the service limit [B], replace both pads in the caliper as a set.

Pad Lining Thickness
Standard:

Front	4.5 mm (0.18 in.)
Rear	6.4 mm (0.25 in.)
Service Limit:	1 mm (0.04 in.)

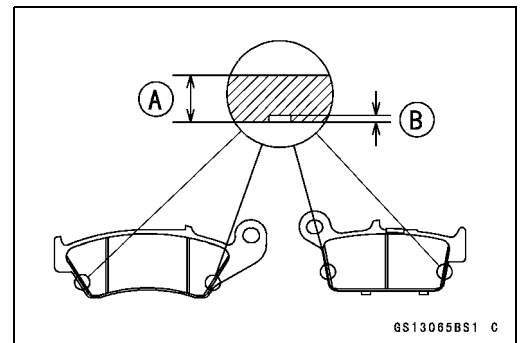

Brake Light Switch Operation Inspection

- Turn the ignition switch ON.
- The brake light [A] should go on when the brake lever is applied or after the brake pedal is depressed about 10 mm (0.39 in.).

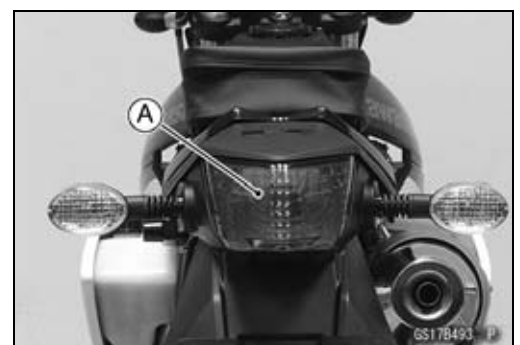

2-34 PERIODIC MAINTENANCE

Periodic Maintenance Procedures

- ★ If it does not, adjust the brake light switch.
- While holding the switch body, turn the adjusting nut to adjust the switch.
 - Switch Body [A]
 - Adjusting Nut [B]
 - Light sooner as the body rises [C]
 - Light later as the body lowers [D]

NOTICE

To avoid damaging the electrical connections inside the switch, be sure that the switch body does not turn during adjustment.

- ★ If it does not go on, inspect or replace the following items.
 - Battery (see Battery Condition in the Electrical System chapter)
 - Brake Light (see Tail/Brake Light Bulb Replacement in the Electrical System chapter)
 - Main Fuse 20 A (see Fuse Inspection in the Electrical System chapter)
 - Front Brake Light Switch [A] (see Switch Inspection in the Electrical System chapter)
 - Rear Brake Light Switch (see Switch Inspection in the Electrical System chapter)
 - Harness (see Wiring Inspection in the Electrical System chapter)

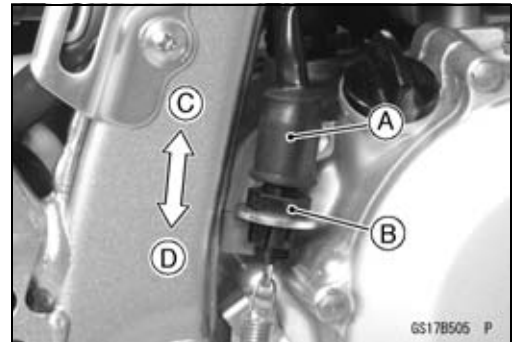

Suspensions

Front Forks/Rear Shock Absorber Operation Inspection

- Pump the forks down and up [A] 4 or 5 times, and inspect the smooth stroke.
- ★ If the forks do not smoothly or noise is found, inspect the fork oil level or fork clamps (see Front Fork Oil Change in the Suspension chapter).
- Pump the tail portion down and up [B] 4 or 5 times, and inspect the smooth stroke.
- ★ If the shock absorber [A] does not smoothly stroke or noise is found, inspect the oil leak (see Rear Shock Absorber Oil Leak Inspection).

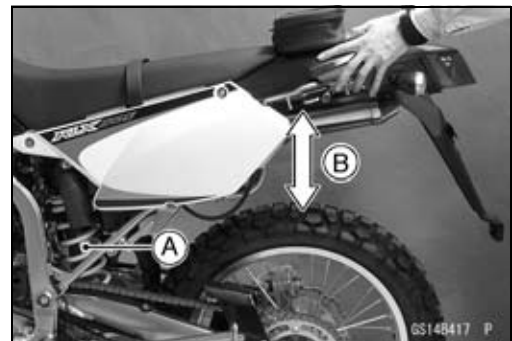
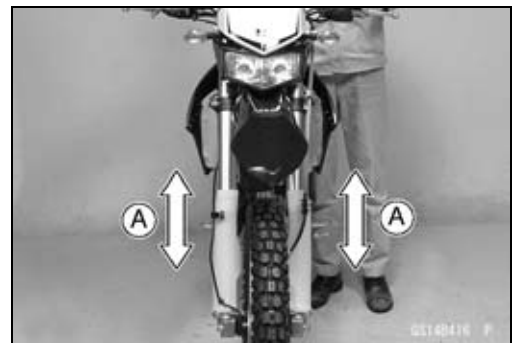

Periodic Maintenance Procedures

Front Fork Oil Leak Inspection

- Visually inspect the front forks [A] for oil leakage.
- ★ Replace or repair any defective parts, if necessary.



Rear Shock Absorber Oil Leak Inspection

- Visually inspect the shock absorber [A] for oil leakage.
- ★ If the oil leakage is found on it, replace the shock absorber with a new one.



Rocker Arm Operation Inspection

- Pump the tail portion down and up 4 or 5 times, and inspect the smooth stroke.
- ★ If the rocker arm [A] does not smoothly stroke or noise is found, inspect the fasteners and bearings (see Rocker Arm/Tie-Rod Bearing, Sleeve Inspection in the Suspension chapter).

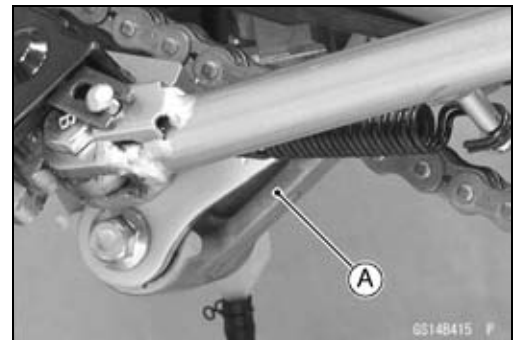

Rocker Arm Bearing Lubrication

- Remove the rocker arm (see Rocker Arm Removal in the Suspension chapter).
- Remove the sleeves [A].
- Using a high-flash point solvent, clean the old grease out of the needle bearings [B].
- Apply plenty of grease to the inner surface of the needle bearings.
- Apply thin coat of grease to the lips of the grease seals [C].
- Install the rocker arm (see Rocker Arm Installation in the Suspension chapter).

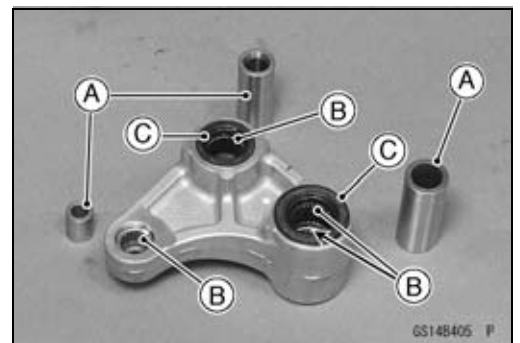

2-36 PERIODIC MAINTENANCE

Periodic Maintenance Procedures

Tie-Rod Operation Inspection

- Pump the tail grip down and up 4 or 5 times, and inspect the smooth stroke.
- ★ If the tie-rods [A] do not smoothly stroke or noise is found, inspect the fasteners and tie-rod bearings (see Rocker Arm/Tie-Rod Bearing, Sleeve Inspection in the Suspension chapter).

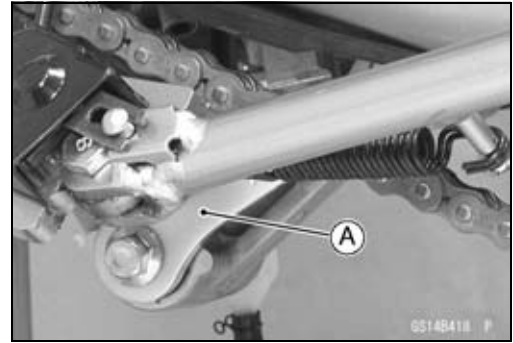

Tie-Rod Bearing Lubrication

- Remove the tie-rods (see Tie-Rod Removal in the Suspension chapter).
- Lubricate the tie-rod bearings in the same way as rocker arm bearings (see Rocker Arm Bearing Lubrication).
- Install the tie-rods (see Tie-Rod Installation in the Suspension chapter).

Swingarm Pivot Lubrication

- Remove the swingarm (see Swingarm Removal in the Suspension chapter).
- Remove the sleeves [A] and grease seals [B].
- Using a high-flash point solvent, clean the old grease out of the needle bearings [C].
- Apply plenty of grease to the inner surface of the needle bearings.
- Apply thin coat of grease to the lips of the grease seals.
- Install the swingarm (see Swingarm Installation in the Suspension chapter).

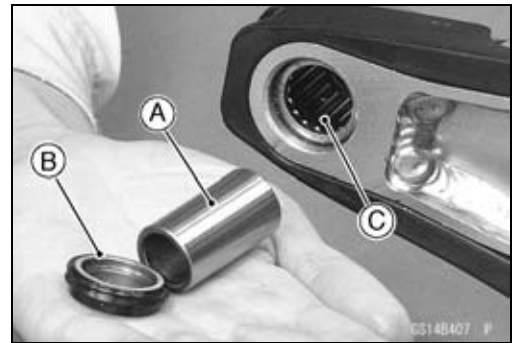

Steering System

Steering Play Inspection

- Raise the front wheel off the ground with jack.
Special Tools - Jack: 57001-1238
- With the front wheel pointing straight ahead, alternately tap each end of the handlebar. The front wheel should swing fully left and right from the force of gravity until the fork hits the stop.
- ★ If the wheel binds or catches before the stop, the steering is too tight.
- Feel for steering looseness by pushing and pulling the forks.
- ★ If you feel looseness, the steering is too loose.



NOTE

- The cables and wiring will have some effect on the motion of the fork which must be taken into account.
- Be sure the leads and cables are properly routed.
- The bearings must be in good condition and properly lubricated in order for any test to be valid.

Periodic Maintenance Procedures

Steering Play Adjustment

- Remove:
 - Handlebar (see Handlebar Removal in the Steering chapter)
- Loosen:
 - Lower Fork Clamp Bolts (see Front Fork Removal in the Suspension chapter)
 - Steering Stem Head Nut [A]
- Adjust the steering stem nut [C], using the steering stem nut wrench [B].

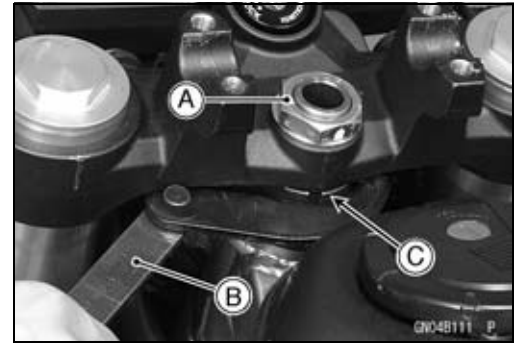

Special Tool - Steering Stem Nut Wrench: 57001-1100

- ★ If the steering is too tight, loosen the stem nut a fraction of a turn.
- ★ If the steering is too loose, tighten the stem nut a fraction of a turn.

NOTE

○ Turn the stem nut 1/8 turn at time maximum.

- Tighten:
 - Torque - Steering Stem Head Nut: 44 N·m (4.5 kgf·m, 32 ft·lb)**
 - Lower Front Fork Clamp Bolts: 25 N·m (2.5 kgf·m, 18 ft·lb)**
- Check the steering again.
- ★ If the steering is still too tight or too loose, repeat the adjustment.

Steering Stem Bearing Lubrication

- Remove the steering stem (see Stem, Stem Bearing Removal in the Steering chapter).
- Using a high-flash point solvent, wash the upper and lower tapered roller bearings [A] in the cages, and wipe the upper and lower outer races, which are press-fitted into the frame head pipe, clean off grease and dirt.
- Visually check the outer races and rollers.
- ★ If the rollers or races are worn, or if either race is dented, replace both races and all the bearings as a set.
- Pack the upper and lower tapered roller bearings in the cages with grease, and apply a light coat of grease to the upper and lower outer races.
- Install the steering stem (see Stem, Stem Bearing Installation in the Steering chapter).
- Adjust the steering (see Steering Play Adjustment).

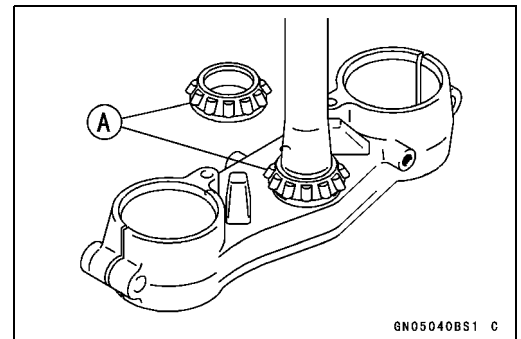

2-38 PERIODIC MAINTENANCE

Periodic Maintenance Procedures

Electrical System

Lights and Switches Operation Inspection

First Step

- Set the gear position in the neutral position.
- Set the lighting switch to ON position (IN model).
- Turn the ignition switch ON.
- The following lights should go on according to below table.

Taillight [A]	goes on
Meter Panel LCD [B]	goes on
Meter Panel Illumination Light (LED) [C]	goes on
FI Indicator Light (LED) [D]	goes on about 3 second
Fuel Level Warning Indicator Light (LED) [E]	goes on about 3 second
Water Temperature Warning Indicator Light (LED) [F]	goes on about 3 second
High beam Indicator Light (LED) [G]	goes on about 3 second
Neutral Indicator Light (LED) [H]	goes on
Turn Signal Indicator Light (LED) [I]	goes on about 3 second
Headlight [J]	goes on
City Light (IN and EUR Models) [K]	goes on

IN and EUR Models [L]

TH Model [M]

- ★ If the light does not go on, inspect or replace the following item.

Battery (see Battery Condition in the Electrical System chapter)

Main Fuse 20 A and Lighting Fuse 10 A (see Fuse Inspection in the Electrical System chapter)

Taillight Bulb (Tail/Brake Light Bulb Replacement in the Electrical System chapter)

Headlight Bulb (see Headlight Bulb Replacement in the Electrical System chapter)

City Light Bulb (see City Light Bulb Replacement in the Electrical System chapter)

Meter Unit for FI Indicator Light (LED) (see Meter Unit Disassembly in the Electrical System chapter)

Meter Unit for Neutral Indicator Light (LED) (see Meter Unit Disassembly in the Electrical System chapter)

ECU (see ECU Power Supply Inspection in the Fuel System (DFI) chapter)

Ignition Switch (see Switch Inspection in the Electrical System chapter)

Lighting Switch (see Switch Inspection in the Electrical System chapter)

Neutral Switch (see Switch Inspection in the Electrical System chapter)

Harness (see Wiring Inspection in the Electrical System chapter)

- Turn the ignition switch OFF.
- The all lights should go off.
- ★ If the light does not go off, replace the ignition switch.

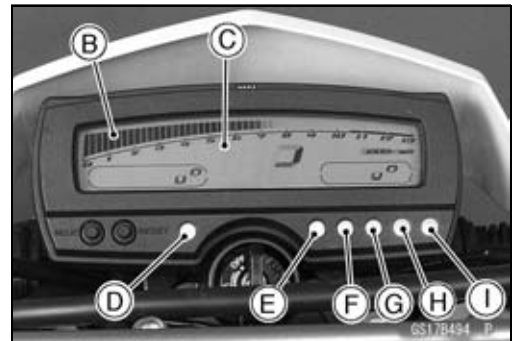
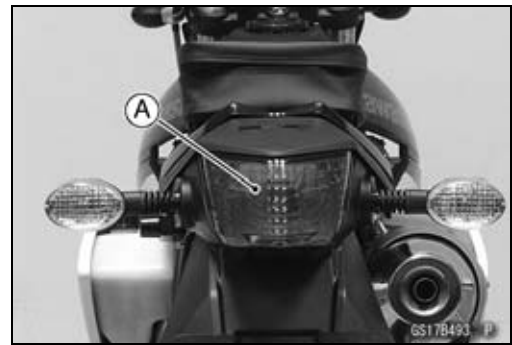

Periodic Maintenance Procedures

Second Step

- Turn on the turn signal switch [A] (left or right position).
- The left or right turn signal lights [B] (front and rear) according to the switch position should flash.
- The turn signal indicator light (LED) [C] in the meter unit should flash.

★ If the each light does not flash, inspect or replace the following item.

Turn Signal Light Bulb (see Turn Signal Light Bulb Replacement in the Electrical System chapter)

Meter Unit for Turn Signal Light Indicator Light (LED) (see Meter Unit Disassembly in the Electrical System chapter)

Turn Signal Switch (see Switch Inspection in the Electrical System chapter)

Turn Signal Relay (see Turn Signal Relay Inspection in the Electrical System chapter)

Harness (see Wiring Inspection in the Electrical System chapter)

- Push the turn signal switch.
 - The turn signal lights and indicator light should go off.
- ★ If the light does not go off, inspect or replace the following item.

Turn Signal Switch (see Switch Inspection in the Electrical System chapter)

Turn Signal Relay (see Turn Signal Relay Inspection in the Electrical System chapter)



Third Step (IN Model)

- Set the lighting switch [A] to PO position.
- Turn the ignition switch ON.
- The city light should go on.

★ If the light does not go on, inspect or replace the following item.

City Light Bulb (see City Light Bulb Replacement in the Electrical System chapter)

Lighting System Fuse 10 A (see Fuse Inspection in the Electrical System chapter)

Lighting Switch (see Switch Inspection in the Electrical System chapter)

Harness (see Wiring Inspection in the Electrical System chapter)

- Set the lighting switch to OFF position.
 - The city light should go off.
- ★ If the light does not go off, inspect or replace the following item.

Lighting Switch (see Switch Inspection in the Electrical System chapter)



2-40 PERIODIC MAINTENANCE

Periodic Maintenance Procedures

Forth Step

- Set the lighting switch to ON position.
- Set the dimmer switch [A] to low beam position.
- Turn the ignition switch ON.
- The low beam headlight should go on.
- ★ If the low beam headlight does not go on, inspect or replace the following item.
 - Headlight Bulb (see Headlight Bulb Replacement in the Electrical System chapter)
 - Lighting System Fuse 10 A (see Fuse Inspection in the Electrical System chapter)
 - Lighting Switch (see Switch Inspection in the Electrical System chapter)
 - Dimmer Switch (see Switch Inspection in the Electrical System chapter)
 - Harness (see Wiring Inspection in the Electrical System chapter)
- Set the dimmer switch to high beam position [A].



- The high beam indicator light (LED) [A] should go on.
- ★ If the high beam headlight and/or high beam indicator light does not go on, inspect or replace the following item.
 - Headlight Bulb (see Headlight Bulb Replacement in the Electrical System chapter)
 - Dimmer Switch (see Switch Inspection in the Electrical System chapter)
- Turn the ignition switch OFF.
- The headlight and high beam indicator light (LED) should go off.

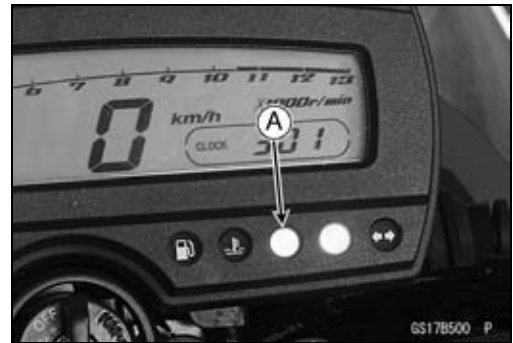

Headlight Aiming Inspection

- Inspect the headlight beam for aiming.
- ★ If the headlight beam points to one side rather than straight ahead, adjust the horizontal beam.

Headlight Beam Horizontal Adjustment (IN and EUR Models)

- Turn the horizontal adjuster [A] on the headlight with the screwdriver in or out until the beam points straight ahead.
- ★ If the headlight beam points too low or high, adjust the vertical beam.



Periodic Maintenance Procedures

Headlight Beam Vertical Adjustment

- Turn the vertical adjuster [A] on the headlight with the screwdriver in or out to adjust the headlight vertically.
IN and Europe Models [B]
TH Model [C]



NOTE

○ON high beam, the brightest points should be slightly below horizontal with the motorcycle on its wheels and the rider seated. Adjust the headlight to the proper angle according to local regulations.

Sidestand Switch Operation Inspection

- Raise the rear wheel off the ground with jack.
Special Tool - Jack: 57001-1238
- Inspect the sidestand switch [A] operation accordance to the following table.

Sidestand Switch Operation

Sidestand	Gear Position	Clutch Lever	Engine Start	Engine Run
Up	Neutral	Released	Starts	Continue running
Up	Neutral	Pulled in	Starts	Continue running
Up	In Gear	Released	Doesn't start	Continue running
Up	In Gear	Pulled in	Starts	Continue running
Down	Neutral	Released	Starts	Continue running
Down	Neutral	Pulled in	Starts	Continue running
Down	In Gear	Released	Doesn't start	Stops
Down	In Gear	Pulled in	Doesn't start	Stops



2-42 PERIODIC MAINTENANCE

Periodic Maintenance Procedures

★ If the sidestand switch operation does not work, inspect or replace the following item.

Battery (see Battery Condition in the Electrical System chapter)

Main Fuse 20 A (see Fuse Inspection in the Electrical System chapter)

ECU Fuse 15 A (see Fuse Inspection in the Electrical System chapter)

Ignition Fuse 10 A (see Fuse Inspection in the Electrical System chapter)

Ignition Switch (see Switch Inspection in the Electrical System chapter)

Sidestand Switch (see Switch Inspection in the Electrical System chapter)

Engine Stop Switch (see Switch Inspection in the Electrical System chapter)

Starter Button (see Switch Inspection in the Electrical System chapter)

Neutral Switch (see Switch Inspection in the Electrical System chapter)

Starter Relay (see Starter Relay Inspection in the Electrical System chapter)

Interlock Diode Unit (see Interlock Diode Unit Inspection in the Electrical System chapter)

Starter Circuit Relay (see Starter Circuit Relay Inspection in the Electrical System chapter)

Harness (see Wiring Inspection in the Electrical System chapter)

★ If all parts are in good condition, replace the ECU.

Engine Stop Switch Operation Inspection

First Step

- Turn the ignition switch ON.
- Set the neutral position.
- Turn the engine stop switch to stop position [A].
- Push the starter button.
- The engine does not start.

★ If the engine starts, inspect or replace the following item.

Engine Stop Switch (see Wiring Inspection in the Electrical System chapter)

Second Step

- Turn the ignition switch ON.
 - Set the neutral position.
 - Turn the engine stop switch to run position [A].
 - Push the starter button and run the engine.
 - Turn the engine stop switch to stop position.
 - Immediately the engine should be stop.
- ★ If the engine does not stop, inspect or replace the following item.

Engine Stop Switch (see Wiring Inspection in the Electrical System chapter)



Periodic Maintenance Procedures

Others

Chassis Parts Lubrication

- Before lubricating each part, clean off any rusty spots with rust remover and wipe off any grease, oil, dirt, or grime.
- Lubricate the points listed below with indicated lubricant.

NOTE

○ *Whenever the vehicle has been operated under wet or rainy conditions, or especially after using a high-pressure water spray, perform the general lubrication.*

Pivots: Lubricate with Grease.

- Brake Lever (Apply silicone grease.)
- Clutch Lever (Apply silicone grease.)
- Brake Pedal
- Sidestand

Points: Lubricate with Grease.

- Clutch Inner Cable Upper and Lower Ends [A]
- Throttle Inner Cable Upper and Lower Ends

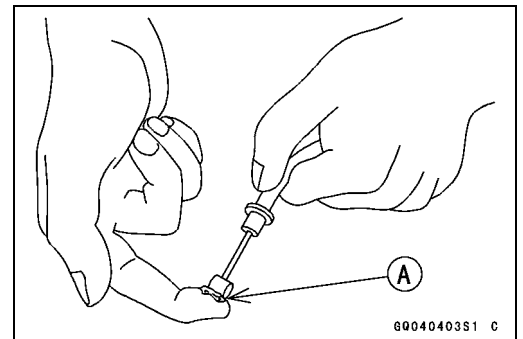

Cables: Lubricate with Rust Inhibitor.

- Clutch Cable
- Throttle Cables

- Lubricate the cables by seeping the oil between the cable and housing.
- The cable may be lubricated by using a commercially available pressure cable lubricator with an aerosol cable lubricant.

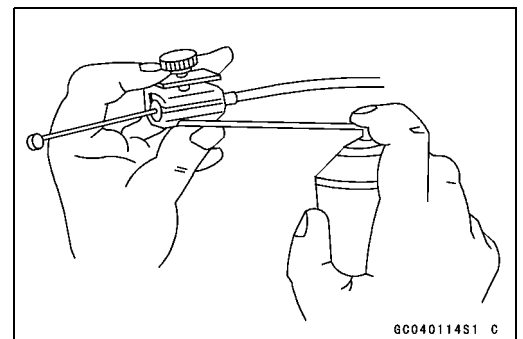

2-44 PERIODIC MAINTENANCE

Periodic Maintenance Procedures

- With the cable disconnected at both ends, the cable should move freely [A] within the cable housing.
- ★ If cable movement is not free after lubricating, if the cable is frayed [B], or if the cable housing is kinked [C], replace the cable.

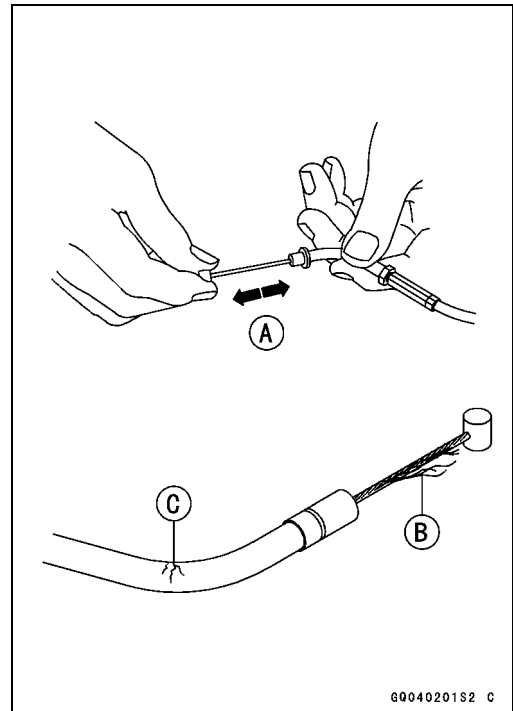

Periodic Maintenance Procedures

Bolts, Nuts and Fasteners Tightness Inspection

- Check the tightness of the bolts and nuts listed here. Also, check to see that each cotter pin is in place and in good condition.

NOTE

○ *For the engine fasteners, check the tightness of them when the engine is cold (at room temperature).*

- ★ If there are loose fasteners, retighten them to the specified torque following the specified tightening sequence. Refer to the appropriate chapter for torque specifications. If torque specifications are not in the appropriate chapter, see the Standard Torque Table. For each fastener, first loosen it by 1/2 turn, then tighten it.
- ★ If cotter pins are damaged, replace them with new ones.

Bolt, Nut and Fastener to be checked

Engine:

Clutch Lever Pivot Bolt Locknut
 Engine Bracket Nuts
 Engine Mounting Bolt and Nuts
 Exhaust Pipe Holder Nuts
 Exhaust Pipe Holder Clamp Bolt
 Muffler Body Bolts
 Radiator Bolts

Wheels:

Front Axle Nut
 Front Axle Clamp Bolts
 Rear Axle Nut
 Rear Axle Nut Cotter Pin

Brakes:

Brake Lever Pivot Bolt and Locknut
 Brake Rod Joint Cotter Pin
 Caliper Mounting Bolts
 Front Master Cylinder Clamp Bolts
 Brake Pad Pins
 Rear Master Cylinder Mounting Bolts

Suspension:

Front Fork Clamp Bolts
 Rear Shock Absorber Bolts
 Swingarm Pivot Shaft Nut
 Tie-Rod Nuts
 Rocker Arm Pivot Shaft Nut

Steering:

Handlebar Holder Bolts
 Steering Stem Head Nut

Others:

Footpeg Bracket Bolts
 Front Fender Bolts
 Sidestand Bolt and Nut

2-46 PERIODIC MAINTENANCE

Periodic Maintenance Procedures

Replacement Parts

Air Cleaner Element Replacement

NOTE

- In dusty areas, the element should be replaced more frequently than the recommended interval.
- After riding through rain or on muddy roads, the element should be replaced immediately.

⚠ WARNING

If dirt or dust is allowed to pass through into the carburetor, the throttle may become stuck, possibly causing accident. Replace the air cleaner element according to the maintenance chart.

- Remove:
 - Seat (see Seat Removal in the Frame chapter)
 - Bolts [A]
 - Air Cleaner Cap [B]
- Remove:
 - Wing Bolt [A] and Washer
 - Air Cleaner Element [B]
- Stuff pieces of lint-free, clean cloth into the air cleaner housing to keep dirt out of the carburetor and engine.

NOTICE

If dirt gets through into the engine, excessive engine wear and possibly engine damage will occur.

- Separate the frame [A] from the element [B].
- Discard the air cleaner element.

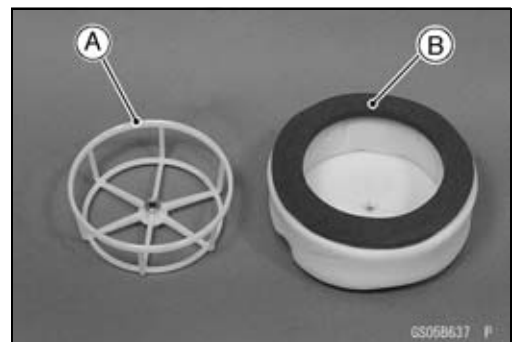
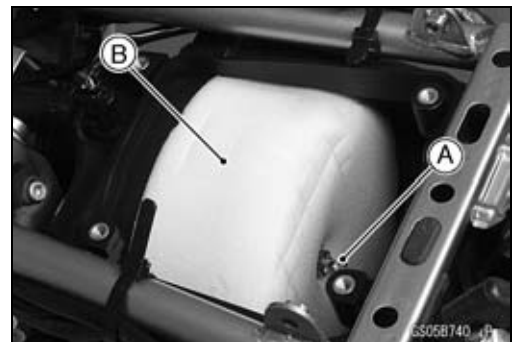
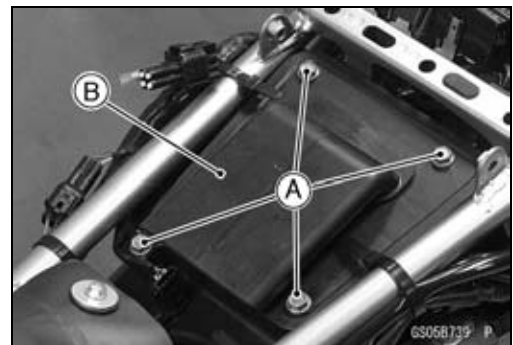

Periodic Maintenance Procedures

- Install the frame into the new element.
- Coat the lip of the element with a thick layer of all purpose grease [A] to assure a complete seal against the air cleaner element base. Also, coat the base where the lip of the element fits.

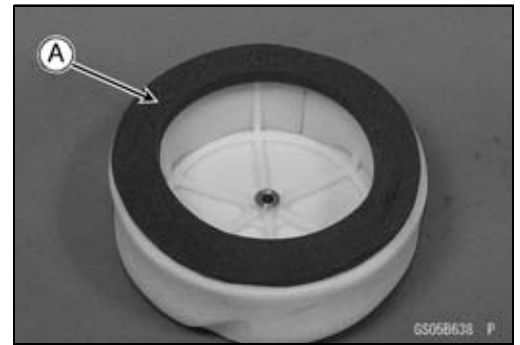

- Install the element, and tighten the wing bolt securely.
- Install the air cleaner cap [A], and tighten the bolts [B].

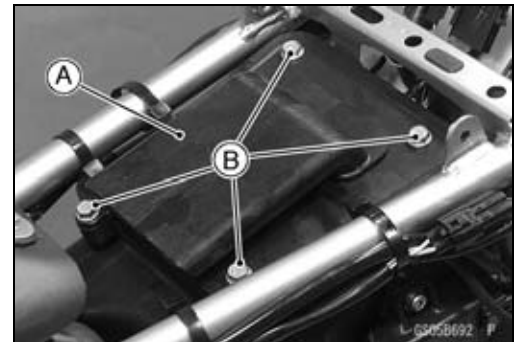

Fuel Hose Replacement

⚠ WARNING

Fuel is flammable and explosive under certain conditions and can cause severe burns. Be prepared for fuel spillage; any spilled fuel must be completely wiped up immediately. When the fuel hose is disconnected, fuel spills out from the hose and the pipe because of residual pressure. Cover the hose connection with a piece of clean cloth to prevent fuel spillage.

- Draw the fuel out from the fuel tank with a commercially available electric pump.
- Remove the fuel tank (see Fuel Tank Removal in the Fuel System (DFI) chapter).
- Be careful of fuel spillage from the fuel tank since fuel still remains in the fuel tank and fuel pump. Plug the fuel pipe of the fuel tank.
- Turn the fuel tank upside down.
- Be sure to place a piece of cloth around the fuel inlet hose [A].
- Remove:
 - Clamps [B]
 - Fuel Inlet Hose

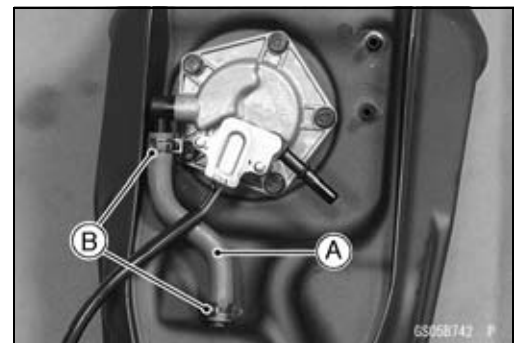

2-48 PERIODIC MAINTENANCE

Periodic Maintenance Procedures

- Be sure to place a piece of cloth [A] around the fuel outlet hose joint.
- Insert a minus screw driver [B] into the slit [C] on the joint lock.
- Turn the driver to disconnect the joint lock [D].

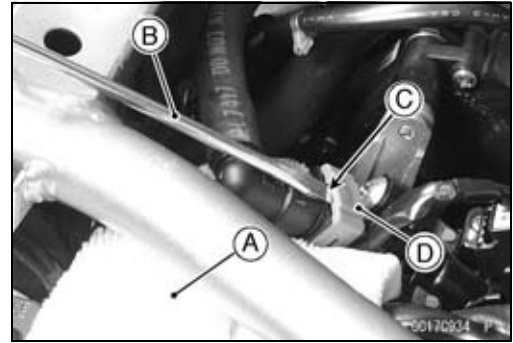

- Pull the fuel hose joint [A] out of the delivery pipe [B].
- Replace the fuel hose with a new one.



- Insert the fuel hose joint [A] straight onto the delivery pipe until the hose joint clicks.
- Push the joint lock [B] until the hose joint clicks.
- Push and pull [C] the fuel hose joint back and forth more than two times, and make sure it is locked and does not come off.

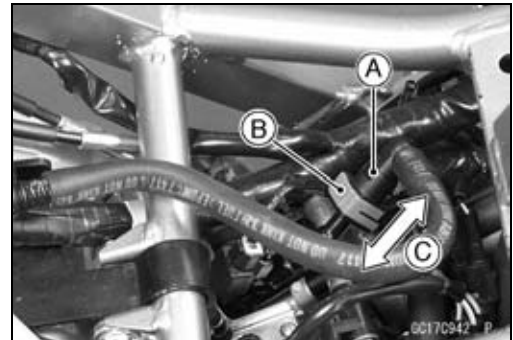

⚠ WARNING

Leaking fuel can cause a fire or explosion resulting in severe burns. Make sure the fuel hose joint is installed correctly on the delivery pipe and that it doesn't leak.

- ★ If it comes off, reinstall the hose joint.
- Install the fuel inlet hose [A], and hold it with the clamps [B].

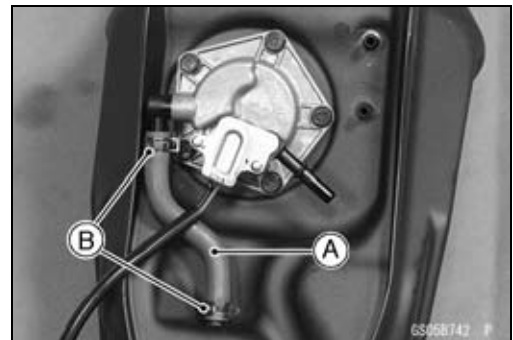

- Run the fuel outlet hose correctly (see Cable, Wire, and Hose Routing section in the Appendix chapter).
- Install the fuel tank (see Fuel Tank Installation in the Fuel System (DFI) chapter).
- Start the engine and check the fuel hose for leaks.

Periodic Maintenance Procedures

Coolant Change

⚠ WARNING

Coolant can be extremely hot and cause severe burns, is toxic and very slippery. Do not remove the radiator cap or attempt to change the coolant when the engine is hot; allow it cool completely. Immediately wipe any spilled coolant from tires, frame, engine or other painted parts. Do not ingest coolant.

- Remove:
Side Cover (see Side Cover Removal in the Frame chapter)
- Place a container under the coolant drain plug [A], then remove the drain plug.

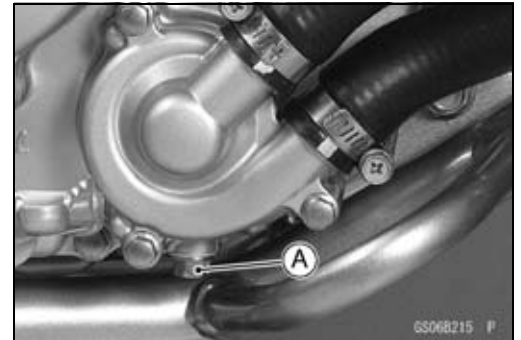

- Remove the radiator cap stop screw [A].
- Remove the radiator cap [B] in two steps. First turn the cap counterclockwise to the first stop. Then push and turn it further in the same direction and remove the cap.
- The coolant will drain from the radiator and engine.

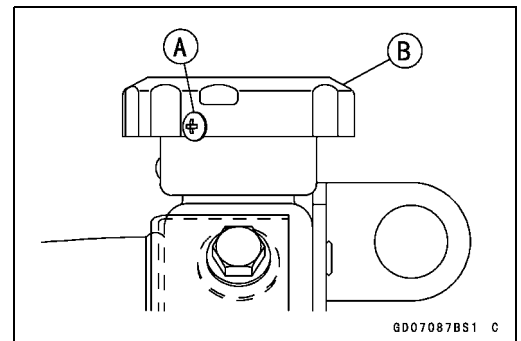

- Remove:
Bolts [A]
Reserve Tank Overflow Hose [B]
- Remove the cap [C], and pour the coolant into a container.
- Install the reserve tank.
- Replace the drain plug gasket with a new one.
- Tighten the drain plug with the gasket.

Torque - Coolant Drain Plug: 25 N·m (2.5 kgf·m, 18 ft·lb)

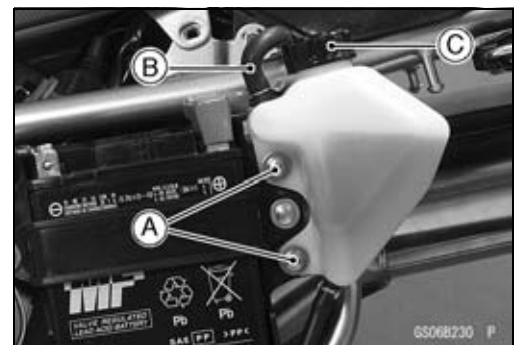

2-50 PERIODIC MAINTENANCE

Periodic Maintenance Procedures

- When filling the coolant, choose a suitable mixture ratio by referring to the coolant manufacturer's directions.

NOTICE

Soft or distilled water must be used with the antifreeze in the cooling system. If hard water is used in the system, it causes scales accumulation in the water passages, and considerably reduces the efficiency of the cooling system.

Water and Coolant Mixture Ratio (Recommended)

Soft Water:	50%
Coolant:	50%
Freezing Point:	-35°C (-31°F)
Total Amount:	1.3 L (1.4 US qt)

- Fill the radiator up to the filler neck [A] with coolant.

NOTE

○ Pour in the coolant slowly so that it can expel the air from the engine and radiator.

- Check the cooling system for leaks.
- Tap the radiator hoses to force any air bubbles caught inside.
- Fill the radiator up to the filler neck with coolant.
- Install the radiator cap.

Torque - Radiator Cap Stop Screw: 2.5 N·m (0.25 kgf·m, 22 in·lb)

- Fill the reserve tank up to the upper level line [A] with coolant and install the cap [B].
- Start the engine, warm it up thoroughly until the radiator fan turns on and then stop the engine.
- Check the coolant level in the reserve tank after the engine cools down.
- ★ If the coolant level is lower than the lower level line [C], add coolant to the upper level line.

NOTICE

Do not add more coolant above the "F" level line.

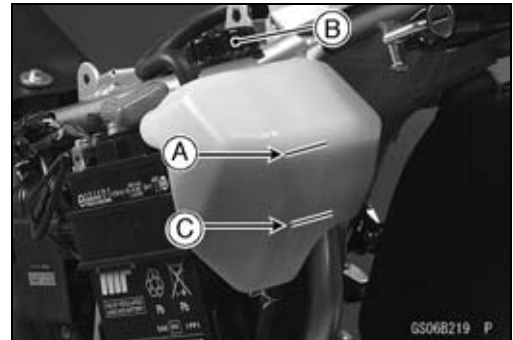

Periodic Maintenance Procedures

Radiator Hose and O-ring Replacement

- Drain the coolant (see Coolant Change).
- Remove:
 - Water Hose Fitting [A]
 - Water Pump Impeller [B] (see Water Pump Removal in the Cooling System chapter)
 - O-rings [C]
 - Hoses [D]
- Apply grease to the new O-rings and install them.
- Tighten:
 - Torque - Water Hose Fitting Bolts: 10 N·m (1.0 kgf·m, 89 in·lb)**
- Install the new hoses and tighten the hose clamp screws.
 - Torque - Radiator Hose Clamp Screws: 1.5 N·m (0.15 kgf·m, 13 in·lb)**
- Fill the coolant (see Coolant Change).
- Check the cooling system for leaks.

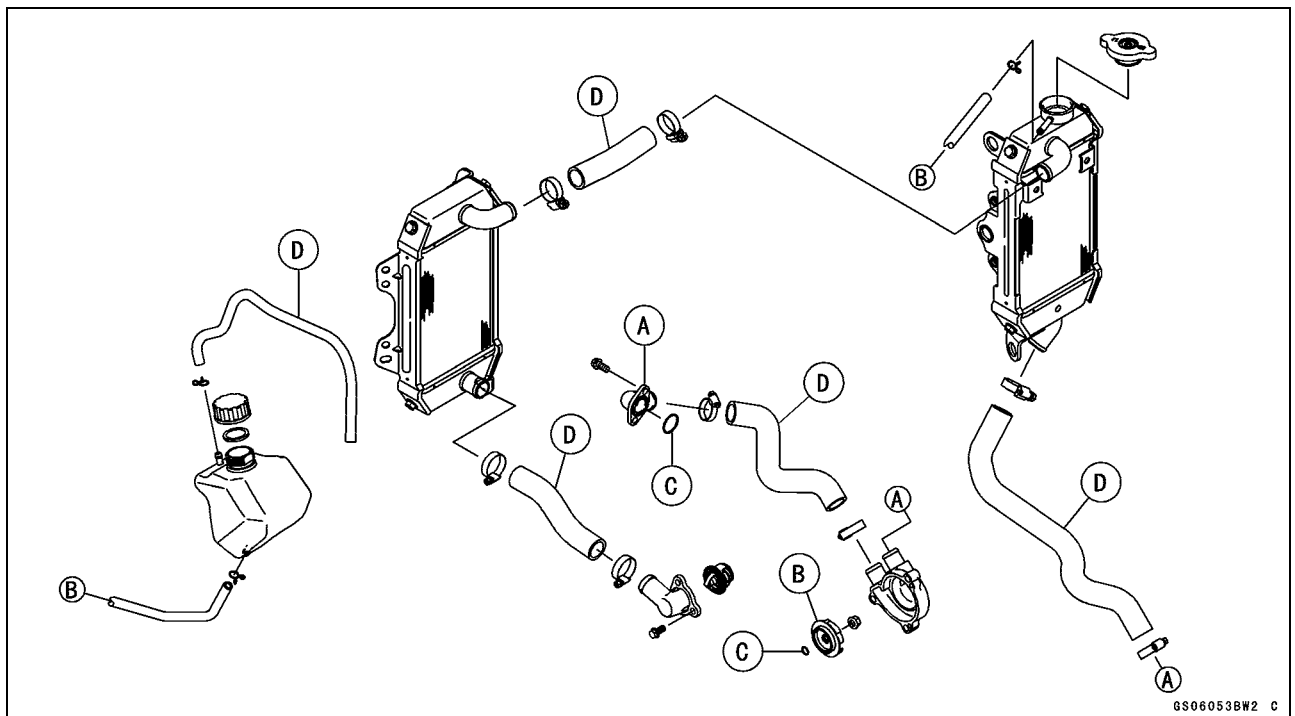

GS06053BW2 C

Engine Oil Change

- Situate the motorcycle so that it is vertical after warming up the engine.
- Remove the engine oil drain plug [A] to drain the oil.
- Replace the drain plug gasket with a new one.
- Tighten the drain plug.
 - Torque - Engine Oil Drain Plug: 15 N·m (1.5 kgf·m, 11 ft·lb)**
- Pour in the specified type and amount of oil.



2-52 PERIODIC MAINTENANCE

Periodic Maintenance Procedures

Recommended Engine Oil

Type: API SG, SH, SJ, SL or SM with JASO MA, MA1 or MA2

Viscosity: SAE 10W-40

Capacity:

KLX250S9F ~ SAF/V9F ~ VAF

1.3 L (1.4 US qt) (when filter is not removed)

1.4 L (1.5 US qt) (when filter is removed)

1.5 L (1.6 US qt) (when engine is completely dry)

KLX250SBF

1.0 L (1.1 US qt) (when filter is not removed)

1.1 L (1.2 US qt) (when filter is removed)

1.3 L (1.4 US qt) (when engine is completely dry)

NOTE

- Do not add any chemical additive to the oil. Oils fulfilling the above requirements are fully formulated and provide adequate lubrication for both the engine and the clutch.
- Although 10W-40 engine oil is the recommended oil for most conditions, the oil viscosity may need to be changed to accommodate atmospheric conditions in your riding area.

● Tighten:

Torque - Oil Filler Cap: Hand-tighten

- Check the oil level (see Oil Level Inspection in the Engine Lubrication System chapter).

Oil Filter Replacement

- Drain the engine oil (see Engine Oil Change).
- Remove:
 - Bolts [A]
 - Oil Filter Cap [B]

- Replace the oil filter [A] with a new one.
- Apply grease to the spring [B] so that it may stay in place without falling off from the oil filter.
- Apply engine oil to the grommet [C].
- Install the oil filter with the grommet side facing out.

NOTICE

If the filter is put in the wrong direction, it blocks oil from flowing to the engine and causes an engine seizure.

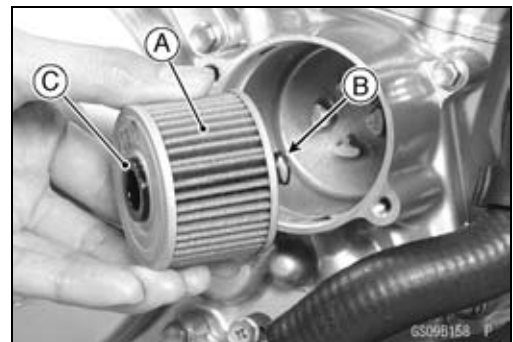
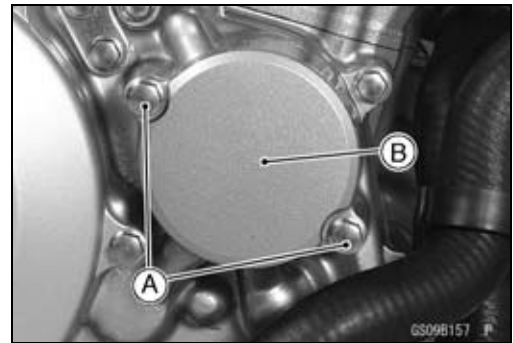
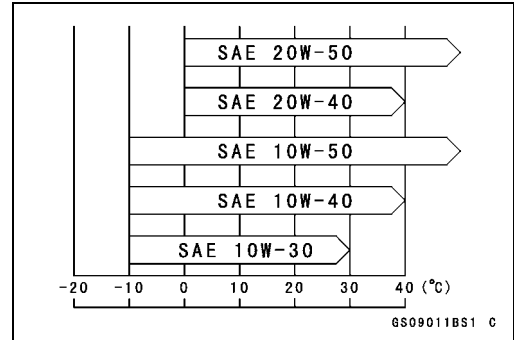

Periodic Maintenance Procedures

- Replace the O-ring [A] of the filter cap with a new one.
- Apply engine oil to the O-ring.
- Install the oil filter cap so that the align the oil passage holes [B] of the oil filter cap and right engine cover.
- Pour in the specified type and amount of oil (see Engine Oil Change).

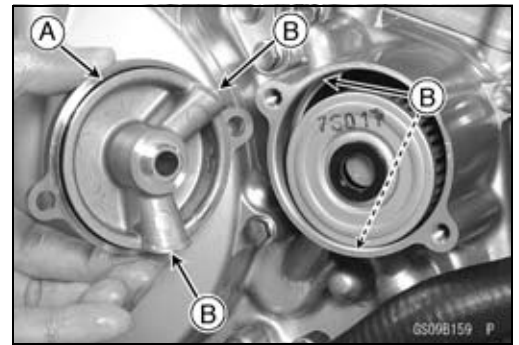

Brake Hose Replacement

NOTICE

Brake fluid quickly ruins painted plastic surfaces; any spilled fluid should be completely washed away immediately.

- Remove the brake hose banjo bolts [A].
- When removing the brake hose, take care not to spill the brake fluid on the painted or plastic parts.
- When removing the brake hoses [B], temporarily secure the end of the brake hose to some high place to keep fluid loss to a minimum.
- Immediately wash away any brake fluid that spills.
- There are washers on each side of the brake hose fitting. Replace them with new ones when installing.
- Tighten:

Torque - Brake Hose Banjo Bolts: 25 N·m (2.5 kgf·m, 18 ft·lb)

- When installing the hoses, avoid sharp bending, kinking, flattening or twisting, and route the hoses according to Cable, Wire, and Hose Routing section in the Appendix chapter.
- Fill the brake line after installing the brake hose (see Brake Fluid Change).

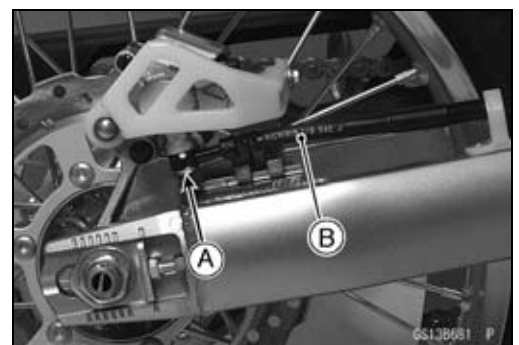
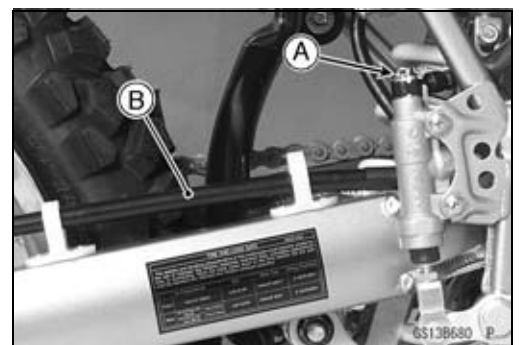
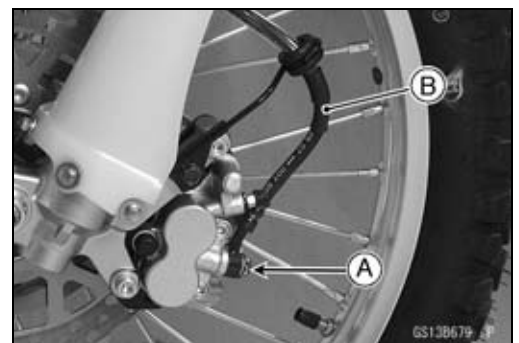
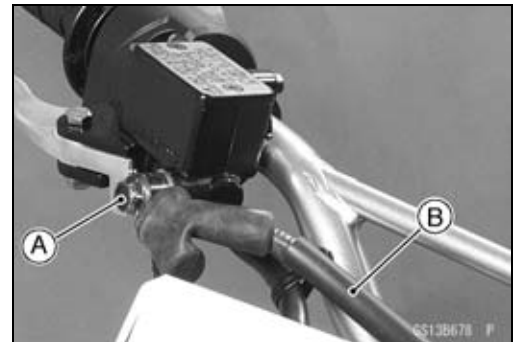

2-54 PERIODIC MAINTENANCE

Periodic Maintenance Procedures

Brake Fluid Change

NOTE

○The procedure to change the front brake fluid is as follows. Changing the rear brake fluid is the same as for the front brake.

- Level the brake fluid reservoir.
- Remove the reservoir cap and diaphragm.
- Remove the rubber cap from the bleed valve [A] on the caliper.
- Attach a clear plastic hose [B] to the bleed valve, and run the other end of the hose into a container.
- Fill the reservoir with fresh specified brake fluid.

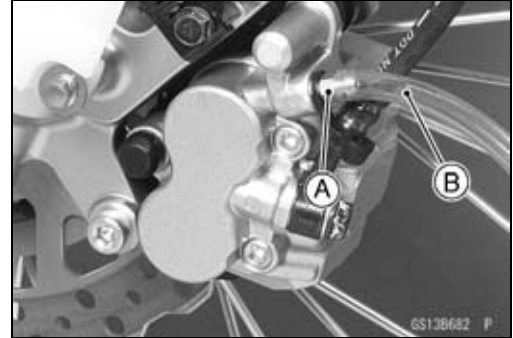

- Change the brake fluid.
- Repeat this operation until fresh brake fluid comes out from the plastic hose or the color of the fluid changes.
1. Open the bleed valve [A].
 2. Apply the brake and hold it [B].
 3. Close the bleed valve [C].
 4. Release the brake [D].

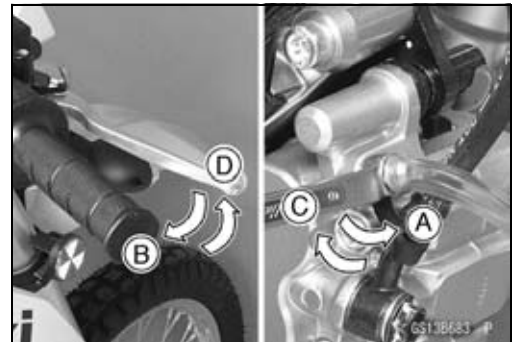

NOTE

○The fluid level must be checked often during the changing operation and replenished with fresh brake fluid. If the fluid in the reservoir runs out any time during the changing operation, the brakes will need to be bled since air will have entered the brake line.

- Remove the clear plastic hose.
- Install the diaphragm and reservoir cap.
- Tighten:
Torque - Master Cylinder Reservoir Cap Screws: 1.5 N·m (0.15 kgf·m, 13 in·lb)
Caliper Bleed Valves: 7.8 N·m (0.80 kgf·m, 69 in·lb)
- Install the rubber cap on the bleed valve.
- After changing the fluid, check the brake for good braking power, no brake drag, and no fluid leakage.
- ★ If necessary, bleed the air from the lines.

Periodic Maintenance Procedures

Master Cylinder Rubber Parts Replacement
Front Master Cylinder Disassembly

- Remove the front master cylinder (see Front Master Cylinder Removal in the Brakes chapter).
- Remove the reservoir cap [A] and diaphragm [B], and pour the brake fluid into a container.
- Unscrew the locknut [C] and pivot bolt [D], and remove the brake lever.
- Pull the dust cover [E] out of place, and remove the circlip [F].

Special Tool - Inside Circlip Pliers: 57001-143

- Remove the washer [G].
- Pull out the piston assy [H].

NOTICE

Do not remove the secondary cup from the piston since removal will damage it.

- Replace:
 Diaphragm [B]
 Dust Cover [E]
 Circlip [F]
 Piston Assy [H]

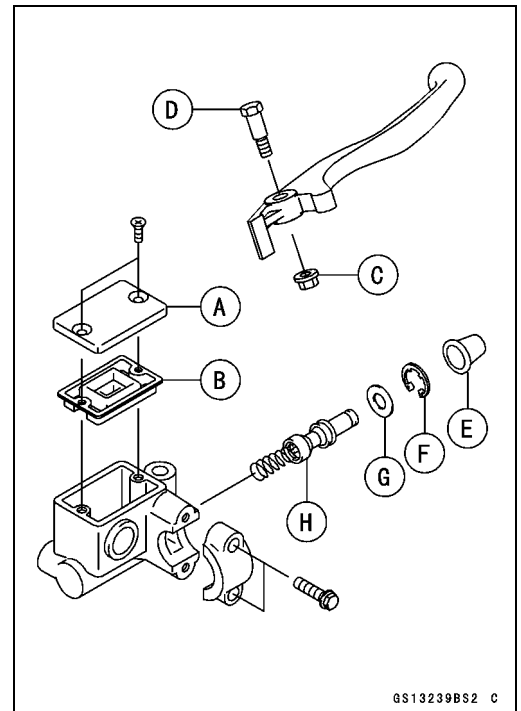

GS13239BS2 C

Rear Master Cylinder Disassembly

- Remove the rear master cylinder (see Rear Master Cylinder Removal in the Brakes chapter).
- Remove the reservoir cap [A] and diaphragm [B], and pour the brake fluid into a container.
- Remove the circlip [C], fitting [D] and O-ring [E].

Special Tool - Inside Circlip Pliers: 57001-143

- Slide the dust cover [F] out of place, and remove the circlip [G].
- Pull out the push rod assy [H].
- Take off the piston assy [I] and return spring [J].

NOTICE

Do not remove the secondary cup from the piston since removal will damage it.

- Replace:
 Diaphragm [B]
 Circlip [C]
 O-ring [E]
 Circlip [G]
 Push Rod Assy [H]
 Piston Assy [I]
 Hose [K]

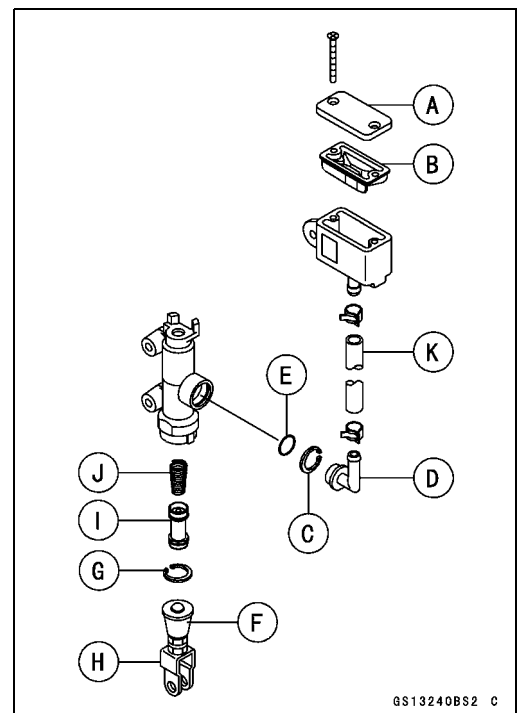

GS13240BS2 C

2-56 PERIODIC MAINTENANCE

Periodic Maintenance Procedures

Master Cylinder Assembly

- Before assembly, clean all parts including the master cylinder with brake fluid or alcohol.

NOTICE

Except for the disc pads and disc, use only disc brake fluid, isopropyl alcohol, or ethyl alcohol for cleaning brake parts. Do not use any other fluid for cleaning these parts. Gasoline, engine oil, or any other petroleum distillate will cause deterioration of the rubber parts. Oil spilled on any part will be difficult to wash off completely, and will eventually deteriorate the rubber used in the disc brake.

- Apply brake fluid to the new parts and to the inner wall of the cylinder.
- Take care not to scratch the piston or the inner wall of the cylinder.
- Apply silicone grease to the brake lever pivot bolt [A].
- Apply silicone grease to the contact surface [B] of the brake lever and piston.
- Tighten:

Torque - Brake Lever Pivot Bolt: 5.9 N·m (0.60 kgf·m, 52 in·lb)

Brake Lever Pivot Bolt Locknut [C]: 5.9 N·m (0.60 kgf·m, 52 in·lb)

Master Cylinder Reservoir Cap Screws [D]: 1.5 N·m (0.15 kgf·m, 13 in·lb)

Front Brake Light Switch Mounting Screw [E]: 1.2 N·m (0.12 kgf·m, 11 in·lb)

- Attach the brake hose [A] and the rear brake reservoir [B] to the rear master cylinder and set the upper hose clamp [C] and the lower hose clamp [D] as shown in the figure.

Section [E]

Section [F]

Front [G]

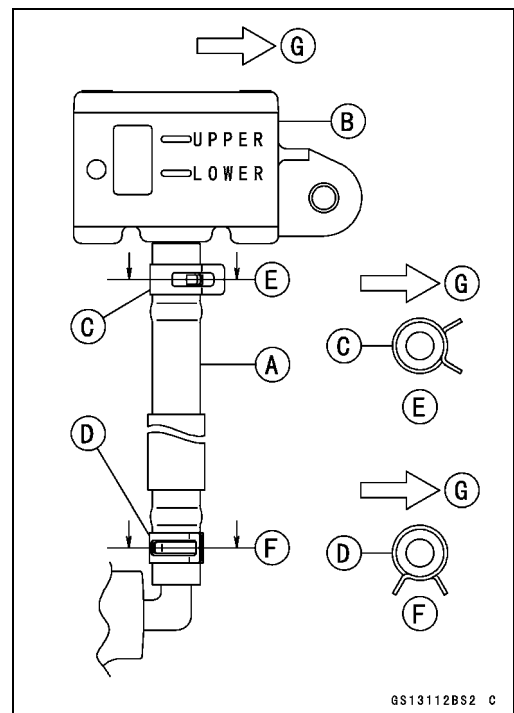
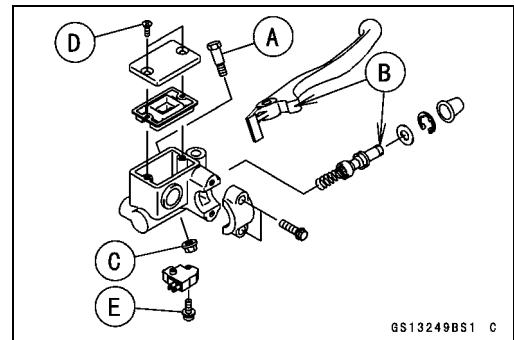

Periodic Maintenance Procedures

Caliper Rubber Parts Replacement

Front Caliper Disassembly

- Remove:
 - Front Caliper (see Front Caliper Removal in the Brakes chapter)
 - Brake Pads (see Front Brake Pad Removal in the Brakes chapter)
- Using compressed air, remove the pistons.
 - Cover the piston area with a clean, thick cloth [A].
 - Blow compressed air [B] into the hole for the banjo bolt to remove the piston.

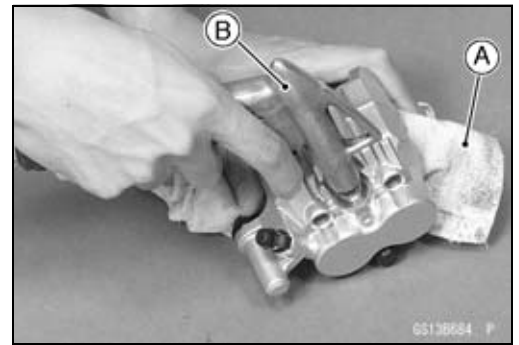

⚠ WARNING

The piston in the brake caliper can crush hands and fingers. Never place your hand or fingers in front of the piston.

- Pull out the pistons by hand.
- Remove the dust seals [A] and fluid seals [B].
- Remove the bleed valve [C] and rubber cap [D].

NOTE

○ If compressed air is not available, with the brake hose still attached, apply the brake lever to remove the piston. The remaining process is as described above.

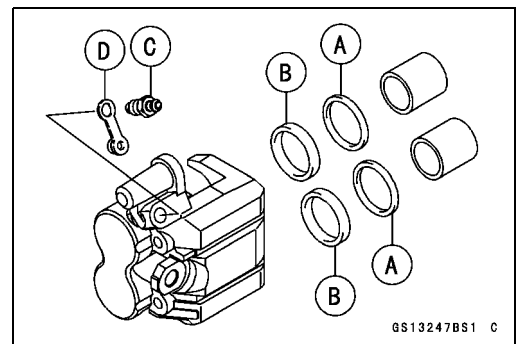

Front Caliper Assembly

- Clean the caliper parts except for the pads.

NOTICE

For cleaning the parts, use only disc brake fluid, isopropyl alcohol, or ethyl alcohol.

- Install the bleed valve and rubber cap.
 - Torque - Caliper Bleed Valves: 7.8 N·m (0.80 kgf·m, 69 in·lb)**
- Replace the fluid seals [A] with new ones.
 - Apply a thin coat of PBC (Poly Butyl Cuprysil) grease to the fluid seals, and install them into the cylinders by hand (PBC is a special high-temperature, water-resistance grease).
- Replace the dust seals [B] with new ones if they are damaged.
 - Apply brake fluid to the dust seals, and install them into the cylinders by hand.

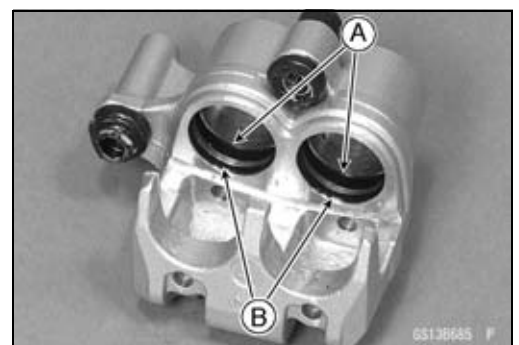

2-58 PERIODIC MAINTENANCE

Periodic Maintenance Procedures

- Install the anti-rattle spring [A] as shown.

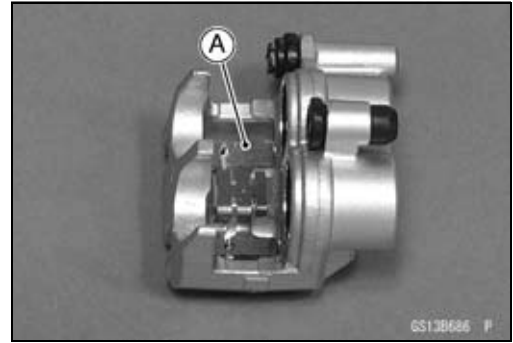

- Apply brake fluid to the outside of the pistons, and push them into each cylinder by hand.
- Check the shaft rubber friction boot [A] and the dust boot [B] replace them with new ones if they are damaged.
- Apply a thin coat of PBC (Poly Butyl Cuprysil) grease to the caliper holder shafts [C] and holder holes [D] (PBC is a special high-temperature, water-resistance grease).
- Install the pads (see Front Brake Pad Installation in the Brakes chapter).
- Wipe up any spilled brake fluid on the caliper with wet cloth.

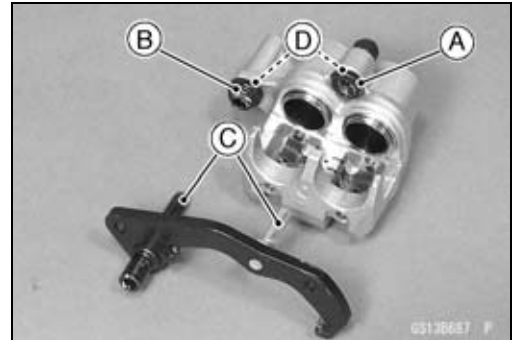

Rear Caliper Disassembly

- Remove:
 - Rear Caliper (see Rear Caliper Removal in the Brakes chapter)
 - Brake Pads (see Rear Brake Pad Removal in the Brakes chapter)
- Using compressed air, remove the pistons.
 - Cover the piston area with a clean, thick cloth [A].
 - Blow compressed air [B] into the hole for the banjo bolt to remove the piston.

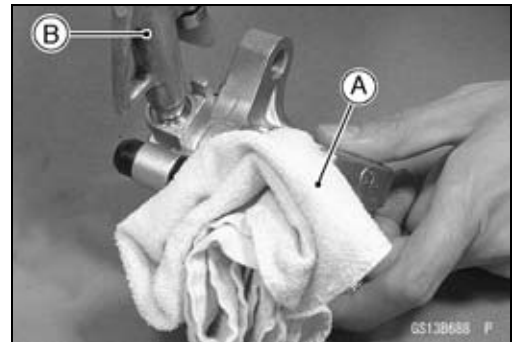

⚠ WARNING

The piston in the brake caliper can crush hands and fingers. Never place your hand or fingers in front of the piston.

- Remove the dust seal [A] and fluid seal [B].
- Remove the bleed valve [C] and rubber cap [D].

NOTE

○ If compressed air is not available, with the brake hose still attached, apply the brake pedal to remove the piston. The remaining process is as described above.

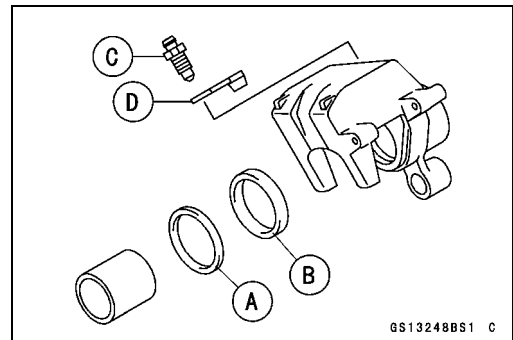

Periodic Maintenance Procedures

Rear Caliper Assembly

- Clean the caliper parts except for the pads.

NOTICE

For cleaning of the parts, use only disc brake fluid, isopropyl alcohol, or ethyl alcohol.

- Install the bleed valve and rubber cap.
- Torque - Bleed Valve: 7.8 N·m (0.80 kgf·m, 69 in·lb)**
- Replace the fluid seal [A] with a new one.
- Apply a thin coat of PBC (Poly Butyl Cuprysil) grease to the fluid seal, and install it into the cylinder by hand (PBC is a special high-temperature, water-resistance grease).
- Replace the dust seal [B] with a new one.
- Apply brake fluid to the dust seal, and install it into the cylinder by hand.

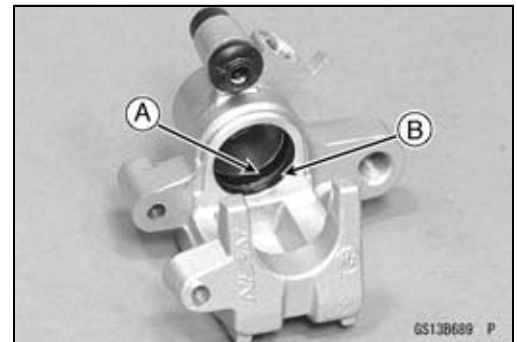

- Install the anti-rattle spring [A] in the caliper as shown.

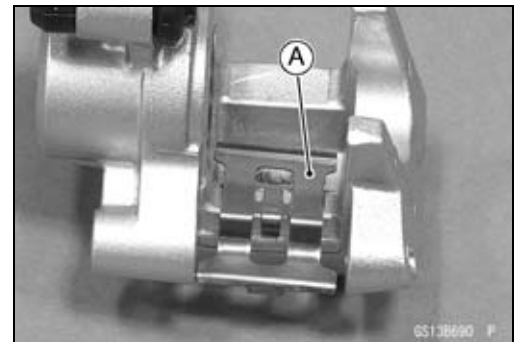

- Apply brake fluid to the outside of the piston, and push it into the cylinder by hand.
- Replace the shaft rubber friction boot [A] and dust boot [B] if they are damaged.
- Apply a thin coat of PBC (Poly Butyl Cuprysil) grease to the caliper holder shaft [C] and holder holes [D] (PBC is a special high-temperature, water-resistance grease).
- Install the pads (see Rear Brake Pad Installation in the Brakes chapter).

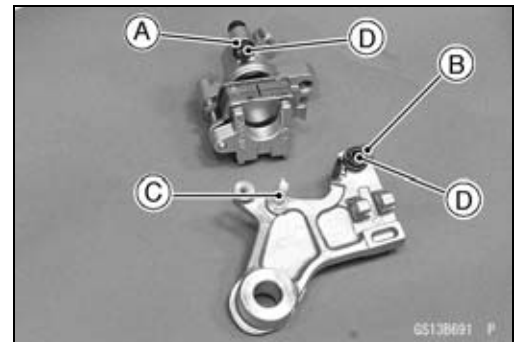

- Apply a thin coat of PBC (Poly Butyl Cuprysil) grease to the rear caliper mounting bolt [A] and tighten it.

Torque - Rear Caliper Mounting Bolt: 27 N·m (2.8 kgf·m, 20 ft·lb)

- Wipe up any spilled brake fluid on the caliper with wet cloth.

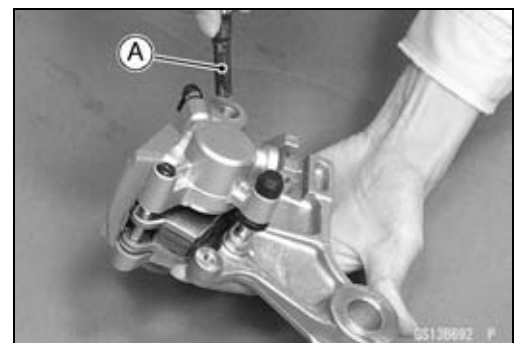

2-60 PERIODIC MAINTENANCE

Periodic Maintenance Procedures

Spark Plug Replacement

- Remove the left radiator shroud (see Radiator Shroud Removal in the Frame System chapter).
- Remove the spark plug cap [A] from the spark plug.
- Remove the spark plug using the plug wrench vertically.

Special Tool - Spark Plug Wrench, Hex 16: 57001-1262

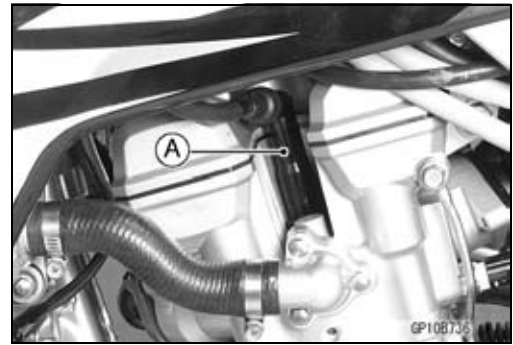

- Replace the spark plug with a new one.

Standard Spark Plug

Type: NGK CR8E or ND U24ESR-N

- Insert the spark plug [A] vertically into the plug hole with the spark plug installed in the plug wrench [B].

Special Tool - Spark Plug Wrench, Hex 16: 57001-1262

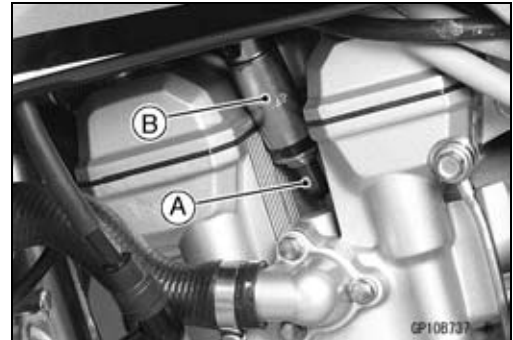

NOTICE

The insulator of the spark plug may break if when the wrench is inclined during tightening.

- Tighten:
Torque - Spark Plug: 13 N·m (1.3 kgf·m, 115 in·lb)
- Install the spark plug cap securely.
- Be sure the spark plug cap is installed by pulling up it lightly.

Fuel System (DFI)

Table of Contents

Exploded View.....	3-4
DFI System.....	3-10
DFI Parts Location.....	3-16
Specifications	3-18
Special Tools and Sealant.....	3-20
DFI Servicing Precautions.....	3-22
DFI Servicing Precautions	3-22
Troubleshooting the DFI System.....	3-24
Outline.....	3-24
Inquiries to Rider.....	3-27
DFI System Troubleshooting Guide	3-30
Self-Diagnosis	3-35
Self-diagnosis Outline	3-35
Self-diagnosis Procedures.....	3-35
How to Read Service Codes.....	3-37
How to Erase Service Codes.....	3-37
Service Code Table.....	3-38
Backups	3-40
Main Throttle Sensor (Service Code 11)	3-43
Main Throttle Sensor Removal/Adjustment	3-43
Main Throttle Sensor Input Voltage Inspection	3-43
Main Throttle Sensor Output Voltage Inspection	3-44
Main Throttle Sensor Resistance Inspection	3-46
Inlet Air Pressure Sensor (Service Code 12).....	3-47
Inlet Air Pressure Sensor Removal.....	3-47
Inlet Air Pressure Sensor Installation.....	3-47
Inlet Air Pressure Sensor Input Voltage Inspection.....	3-48
Inlet Air Pressure Sensor Output Voltage Inspection.....	3-49
Inlet Air Temperature Sensor (Service Code 13).....	3-52
Inlet Air Temperature Sensor Removal/Installation.....	3-52
Inlet Air Temperature Sensor Output Voltage Inspection	3-52
Inlet Air Temperature Sensor Resistance Inspection	3-53
Water Temperature Sensor (Service Code 14)	3-55
Water Temperature Sensor Removal/Installation	3-55
Water Temperature Sensor Output Voltage Inspection.....	3-55
Water Temperature Sensor Resistance Inspection.....	3-56
Crankshaft Sensor (Service Code 21).....	3-57
Crankshaft Sensor Removal/Installation	3-57
Crankshaft Sensor Resistance Inspection	3-57
Crankshaft Sensor Peak Voltage Inspection.....	3-57
Speed Sensor (Service Code 24).....	3-58
Speed Sensor Removal/Installation.....	3-58
Speed Sensor Input Voltage Inspection.....	3-58
Speed Sensor Output Voltage Inspection	3-59
Vehicle-down Sensor (Service Code 31).....	3-61
Vehicle-down Sensor Removal.....	3-61
Vehicle-down Sensor Installation	3-62
Vehicle-down Sensor Input Voltage Inspection.....	3-62
Vehicle-down Sensor Output Voltage Inspection	3-63
Subthrottle Sensor (Service Code 32: TH and EUR Models/Service Code 62: IN Model)	3-65

3-2 FUEL SYSTEM (DFI)

Subthrottle Sensor Removal/Adjustment	3-65
Subthrottle Sensor Input Voltage Inspection	3-65
Subthrottle Sensor Output Voltage Inspection	3-66
Subthrottle Sensor Resistance Inspection	3-68
Oxygen Sensor - not activated (Service Code 33)	3-69
Oxygen Sensor Removal/Installation	3-69
Oxygen Sensor Inspection	3-69
Fuel Injector (Service Code 41)	3-72
Fuel Injector Removal	3-72
Fuel Injector Installation	3-72
Fuel Injector Audible Inspection	3-74
Fuel Injector Resistance Inspection	3-74
Fuel Injector Power Supply Voltage Inspection	3-75
Fuel Injector Output Voltage Inspection	3-75
Injector Fuel Line Inspection	3-76
Fuel Pump Relay (Service Code 46)	3-78
Fuel Pump Relay Removal	3-78
Fuel Pump Relay Inspection	3-78
Ignition Coil (Service Code 51)	3-80
Ignition Coil Removal/Installation	3-80
Ignition Coil Input Voltage Inspection	3-80
Radiator Fan Relay (Service Code 56)	3-82
Radiator Fan Relay Removal/Installation	3-82
Radiator Fan Relay Inspection	3-82
Subthrottle Valve Actuator (Service Code 62: TH and EUR Models/Service Code 32: IN Model)	3-83
Subthrottle Valve Actuator Removal	3-83
Subthrottle Valve Actuator Inspection	3-83
Subthrottle Valve Actuator Resistance Inspection	3-83
Subthrottle Valve Actuator Input Voltage Inspection	3-84
Air Switching Valve (Service Code 64)	3-86
Air Switching Valve Removal/Installation	3-86
Air Switching Valve Inspection	3-86
Oxygen Sensor Heater (Service Code 67)	3-87
Oxygen Sensor Heater Removal/Installation	3-87
Oxygen Sensor Heater Resistance Inspection	3-87
Oxygen Sensor Heater Power Source Voltage Inspection	3-87
FI Indicator Light (LED)	3-89
FI Indicator Light (LED) Inspection	3-89
ECU	3-91
ECU Identification	3-91
ECU Removal	3-91
ECU Installation	3-92
ECU Power Supply Inspection	3-92
DFI Power Source	3-95
ECU Fuse Removal	3-95
ECU Fuse Installation	3-95
ECU Fuse Inspection	3-95
Fuel Line	3-96
Fuel Pressure Inspection	3-96
Fuel Flow Rate Inspection	3-97
Fuel Pump	3-99
Fuel Pump Removal	3-99
Fuel Pump Installation	3-100
Fuel Pump Operation Inspection	3-100
Fuel Pump Operating Voltage Inspection	3-101
Pressure Regulator Removal	3-102

Fuel Filter Cleaning.....	3-102
Throttle Grip and Cables	3-104
Throttle Grip Free Play Inspection	3-104
Throttle Grip Free Play Adjustment.....	3-104
Throttle Cable Remove	3-104
Throttle Cable Installation	3-105
Cable Lubrication	3-105
Throttle Body Assy	3-106
Idle Speed Inspection	3-106
Throttle Bore Cleaning.....	3-106
Throttle Body Assy Removal.....	3-106
Throttle Body Assy Installation.....	3-107
Throttle Body Assy Disassembly	3-107
Throttle Body Assy Assembly	3-108
Air Cleaner.....	3-110
Air Cleaner Element Removal/Installation	3-110
Air Cleaner Element Inspection	3-110
Air Cleaner Housing Removal.....	3-110
Air Cleaner Housing Installation.....	3-111
Fuel Tank.....	3-112
Fuel Tank Removal	3-112
Fuel Tank Installation	3-113
Fuel Tank Inspection	3-114
Fuel Tank Cleaning	3-115
Evaporative Emission Control System (SEA and TH Models)	3-116
Parts Removal/Installation	3-116
Hose Inspection	3-116
Separator Inspection.....	3-116
Separator Operation Test.....	3-117
Canister Inspection	3-117

Exploded View

No.	Fastener	Torque			Remarks
		N·m	kgf·m	ft·lb	
1	Front Air Cleaner Duct Clamp Screw	2.0	0.20	18 in·lb	
2	ECU Bracket Screws	5.0	0.51	44 in·lb	
3	Inlet Air Temperature Sensor Mounting Screw	1.2	0.12	11 in·lb	

4. Air Switching Valve

5. Fuel Injector

6. Throttle Body Assy

7. Breather Hose

8. ECU

9. IN Model

CL: Apply cable lubricant.

G: Apply grease.

O: Apply high-quality foam air filter oil.

R: Replacement Parts

3-6 FUEL SYSTEM (DFI)

Exploded View

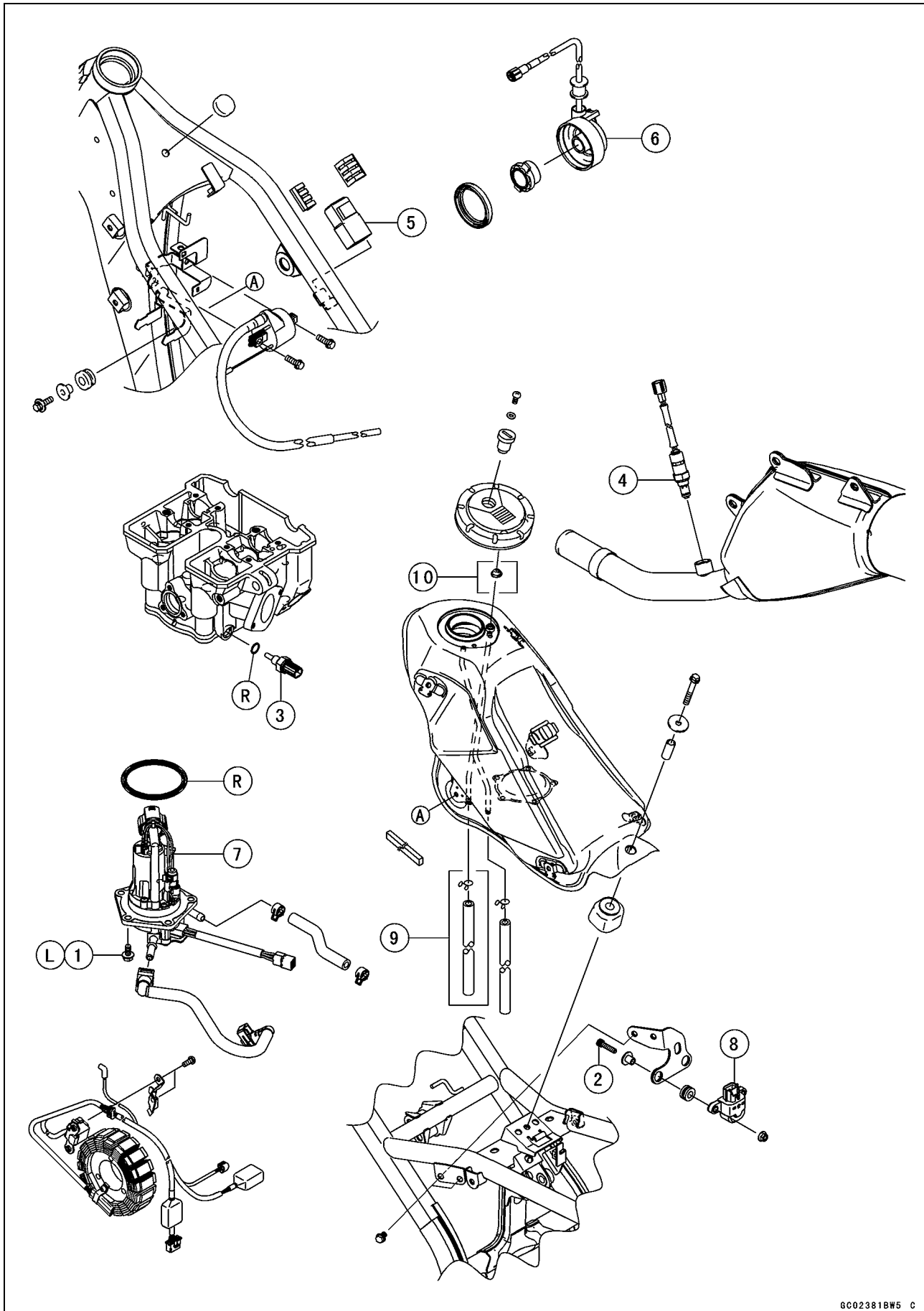

Exploded View

No.	Fastener	Torque			Remarks
		N·m	kgf·m	ft·lb	
1	Fuel Pump Bolts	9.8	1.0	87 in·lb	L
2	Vehicle-down Sensor Mounting Bolts	6.9	0.70	61 in·lb	
3	Water Temperature Sensor	12	1.2	106 in·lb	
4	Oxygen Sensor	25	2.5	18	

5. Fuel Pump Relay

6. Speed Sensor

7. Fuel Pump

8. Vehicle-down Sensor

9. IN and EUR Models

10. TH Model

L: Apply a non-permanent locking agent.

R: Replacement Parts

3-8 FUEL SYSTEM (DFI)

Exploded View

SEA and TH Models

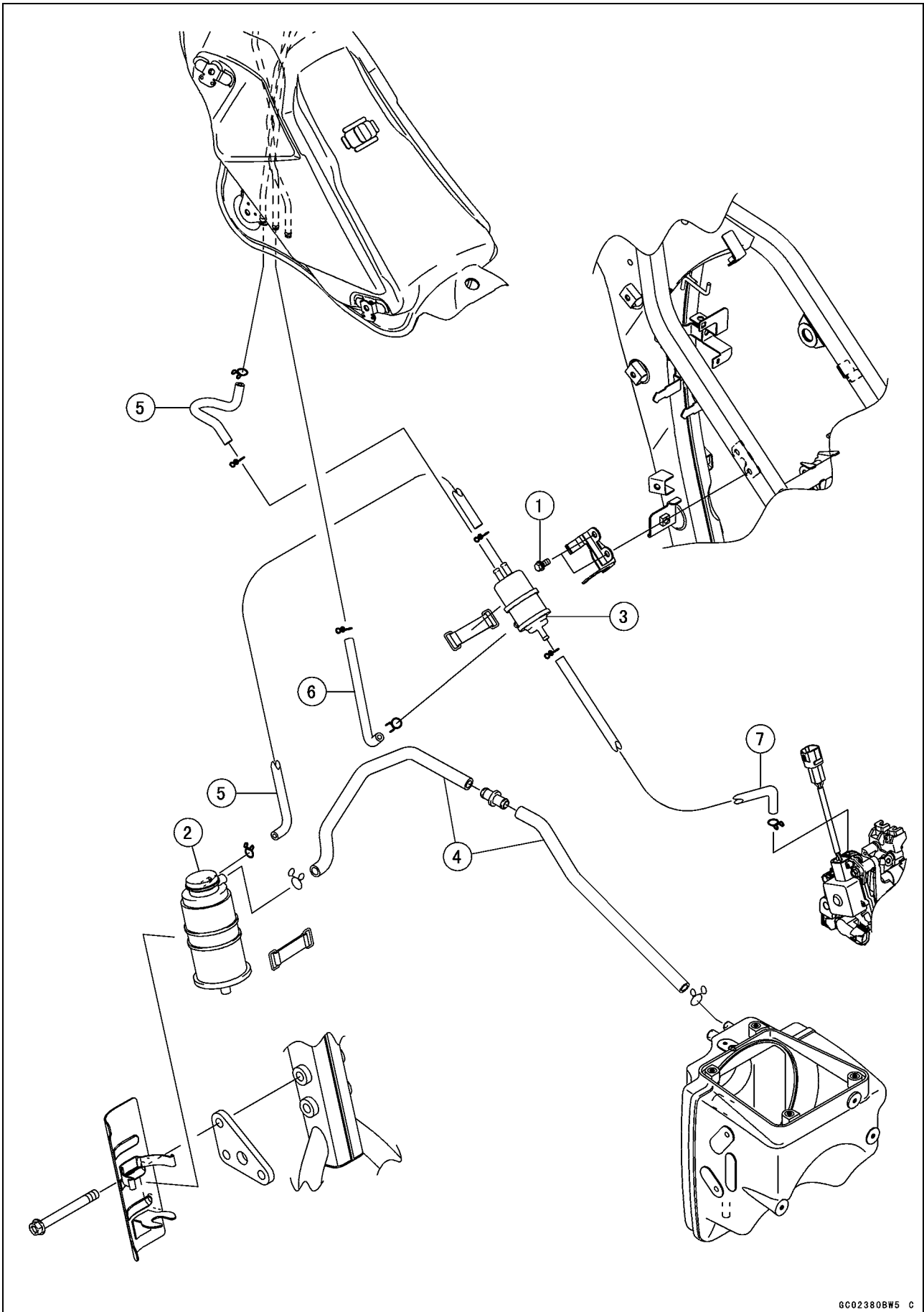

Exploded View

No.	Fastener	Torque			Remarks
		N·m	kgf·m	ft·lb	
1	Separator Bracket Bolts	9.8	1.0	87 in·lb	

2. Canister
3. Separator
4. Green/White Hose
5. Blue Hose
6. Red Hose
7. White Hose

3-10 FUEL SYSTEM (DFI)

DFI System

DFI System

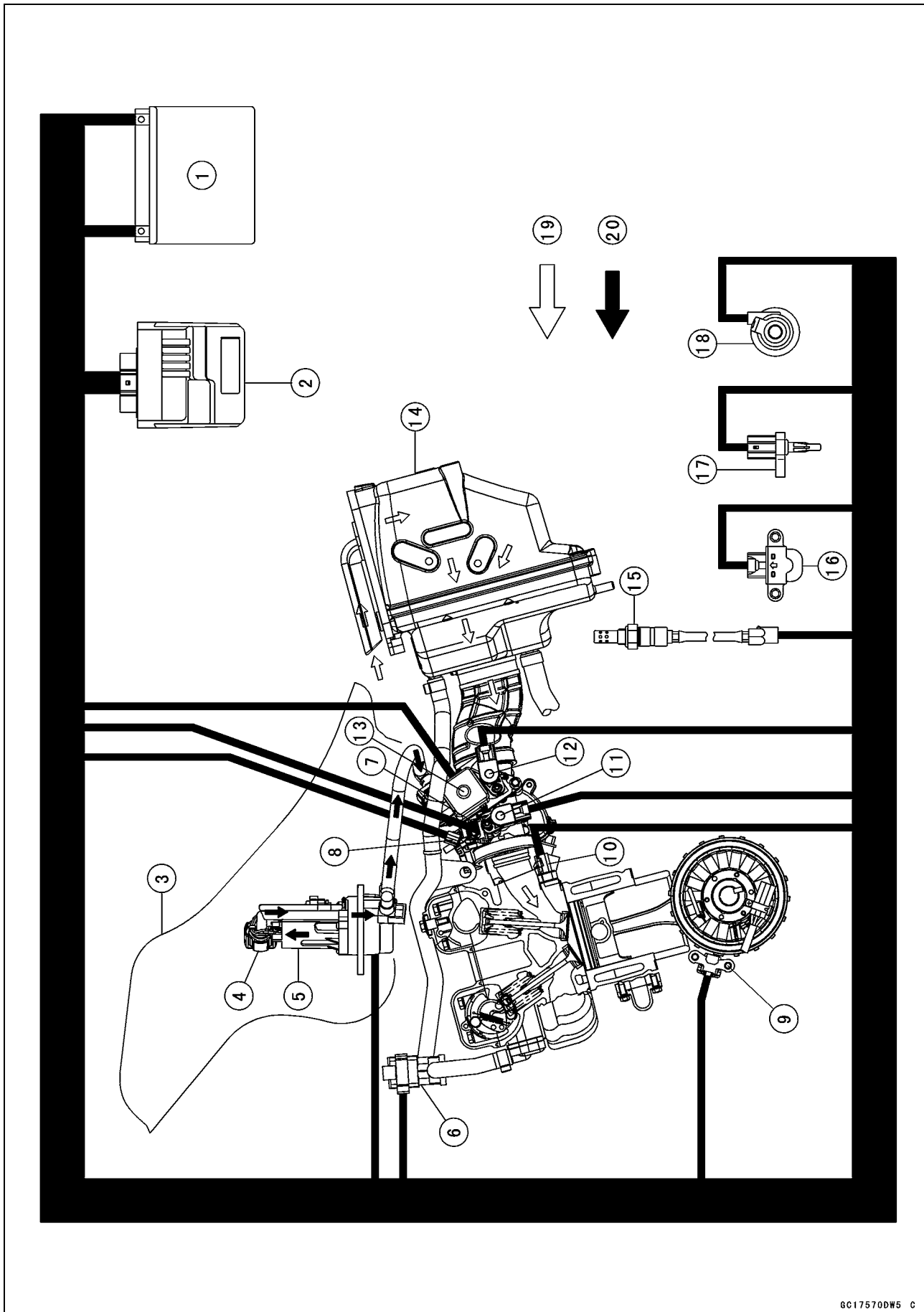

DFI System

1. Battery 12 V 6 Ah
2. ECU
3. Fuel Tank
4. Pressure Regulator
5. Fuel Pump
6. Air Switching Valve
7. Inlet Air Pressure Sensor
8. Fuel Injectors
9. Crankshaft Sensor
10. Water Temperature Sensor
11. Main Throttle Sensor
12. Subthrottle Sensor
13. Subthrottle Valve Actuator
14. Air Cleaner Housing
15. Oxygen Sensor
16. Vehicle-down Sensor
17. Inlet Air Temperature Sensor
18. Speed Sensor
19. Air Flow
20. Fuel Flow

3-12 FUEL SYSTEM (DFI)

DFI System

DFI System Wiring Diagram

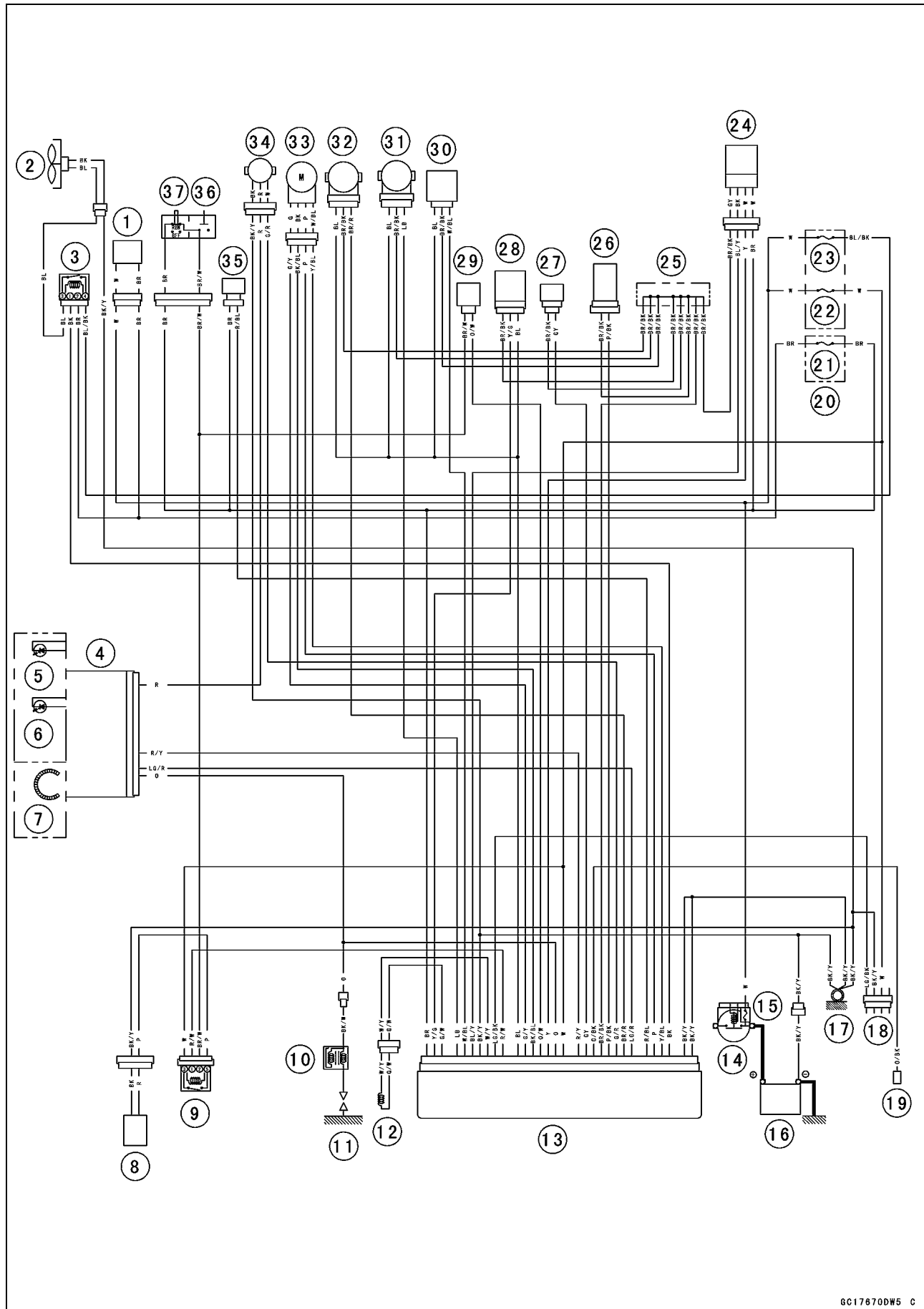

DFI System

Part Names

1. Ignition Switch
2. Fan Motor
3. Radiator Fan Relay
4. Meter Unit
5. Water Temperature Warning Indicator Light (LED)
6. FI Indicator Light (LED)
7. Tachometer
8. Fuel Pump
9. Fuel Pump Relay
10. Ignition Coil
11. Spark Plug
12. Crankshaft Sensor
13. ECU
14. Starter Relay
15. Main Fuse 20 A
16. Battery 12 V 6 Ah
17. Frame Ground
18. Kawasaki Diagnostic System Connector
19. Self-diagnosis Terminal
20. Fuse Box
21. Ignition Fuse 10 A
22. ECU Fuse 15 A
23. Radiator Fan Fuse 10 A
24. Oxygen Sensor
25. Water-proof Joint
26. Inlet Air Temperature Sensor
27. Water Temperature Sensor
28. Vehicle-down Sensor
29. Fuel Injector
30. Inlet Air Pressure Sensor
31. Main Throttle Sensor
32. Subthrottle Sensor
33. Subthrottle Valve Actuator
34. Speed Sensor
35. Air Switching Valve
36. Starter Button
37. Engine Stop Switch

○Color Codes:

BK: Black	GY: Gray	PU: Purple
BL: Blue	LB: Light Blue	R: Red
BR: Brown	LG: Light Green	V: Violet
CH: Chocolate	O: Orange	W: White
DG: Dark Green	P: Pink	Y: Yellow
G: Green		

3-14 FUEL SYSTEM (DFI)

DFI System

Terminal Numbers of ECU Connectors

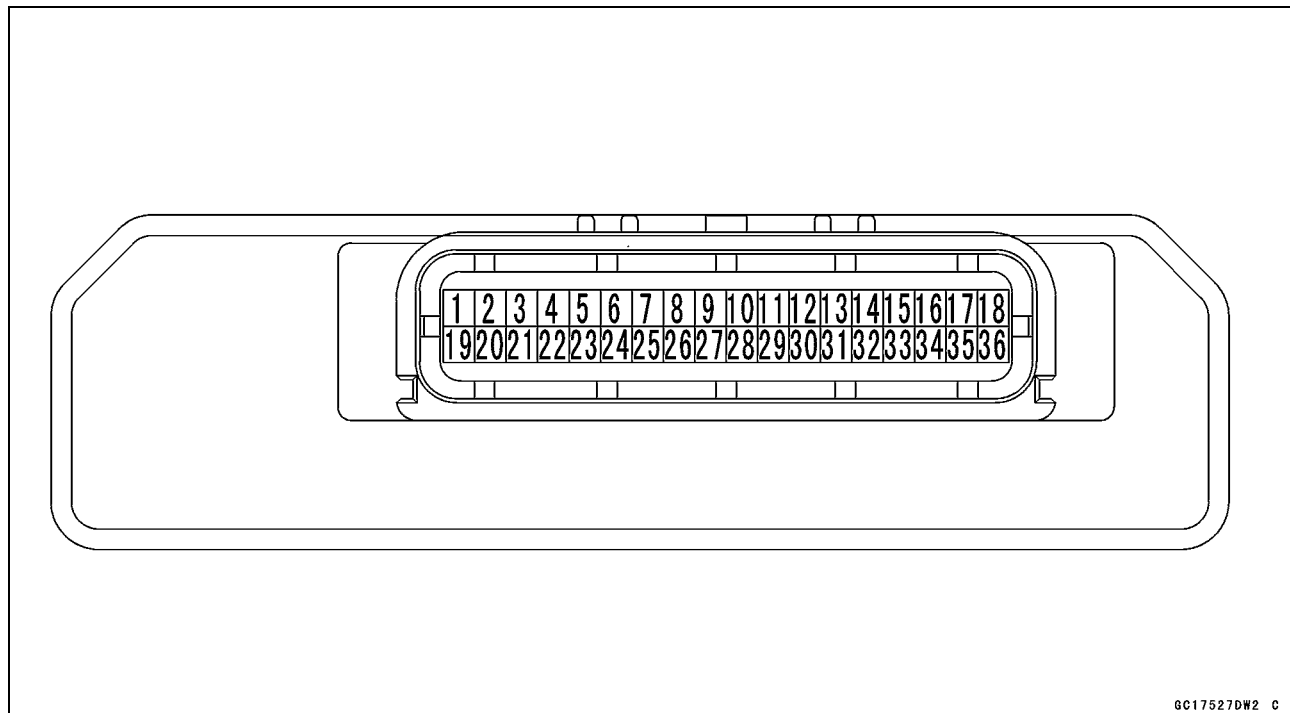

GC17527DW2 C

Terminal Names

1. Power Supply to ECU (from Ignition Switch)
2. Vehicle-down Sensor
3. Crankshaft Sensor (+)
4. Unused
5. Main Throttle Sensor
6. Inlet Air Pressure Sensor
7. Oxygen Sensor
8. Ground for Control System
9. Crankshaft Sensor
10. External Communication Line (*KDS)
11. Fuel Pump Relay
12. Starter Lockout Switch
13. Power Supply to Sensors
14. Subthrottle Valve Actuator B
15. Subthrottle Valve Actuator A
16. Injector
17. Oxygen Sensor
18. Ignition Coil
19. Power Supply to ECU (from Battery)
20. Neutral Switch
21. FI Indicator Light (LED)
22. Water Temperature Sensor
23. Self-diagnosis Terminal
24. Ground for Sensors
25. Inlet Air Temperature Sensor
26. Speed Sensor
27. Subthrottle Sensor
28. Water Temperature Warning Indicator Light (LED)
29. Sidestand Switch
30. Air Switching Valve
31. Subthrottle Valve Actuator A
32. Subthrottle Valve Actuator B
33. Radiator Fan Relay
34. Engine Stop Switch



DFI System

35. Ground for ECU

36. Ground for ECU

*: KDS (Kawasaki Diagnostic System)

3-16 FUEL SYSTEM (DFI)

DFI Parts Location

ECU [A]

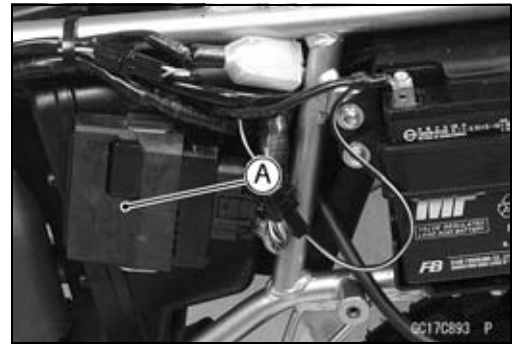

Self-diagnosis Terminal [A]
Kawasaki Diagnostic System Connector [B]
Oxygen Sensor [C]

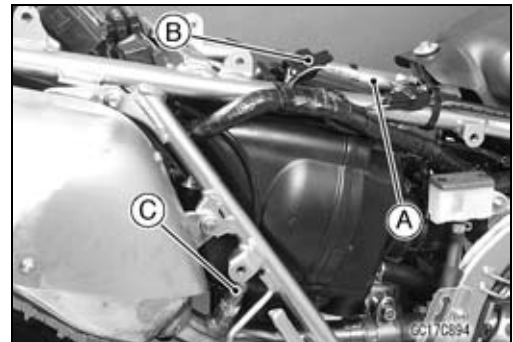

Fuel Pump [A]
Fuel Pump Relay [B]
Throttle Body Assy [C]

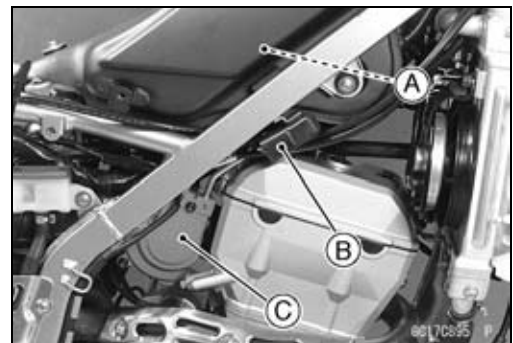

Inlet Air Temperature Sensor [A]



Main Throttle Sensor [A]



DFI Parts Location

Vehicle-down Sensor [A]
Subthrottle Sensor [B]
Water Temperature Sensor [C]
Subthrottle Valve Actuator [D]

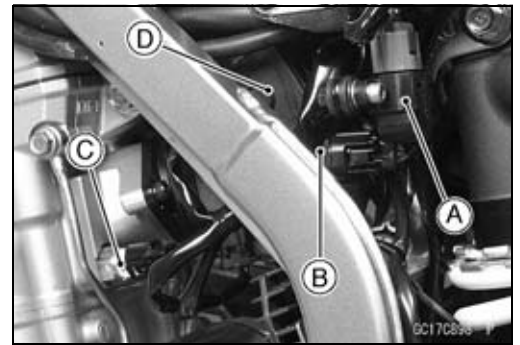

Fuel Injector [A]
Inlet Air Pressure Sensor [B]

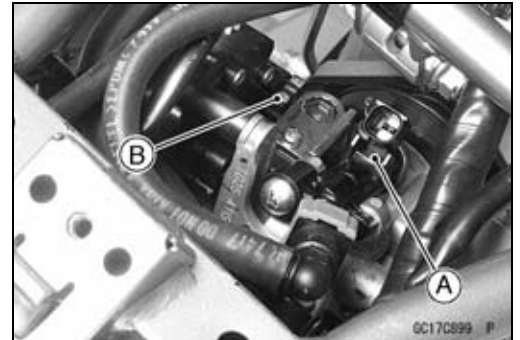

Ignition Coil [A]
Air Switching Valve [B]

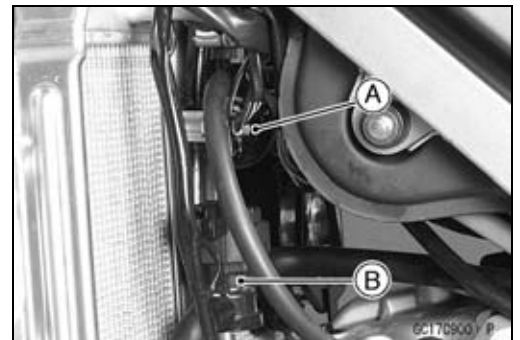

Speed Sensor [A]



ECU Fuse 15 A [A]



3-18 FUEL SYSTEM (DFI)

Specifications

Item	Standard
Digital Fuel Injection System	
Idle Speed	1 300 ±50 r/min (rpm)
Throttle Body Assy:	
Type	Single barrel
Bore	φ34 mm (1.34 in.)
ECU:	
Make	KEIHIN
Type	Digital memory type, with built in IC igniter, sealed with resin
Fuel Pressure (High Pressure Line)	294 kPa (3.0 kgf/cm ² , 43 psi) with engine idling
Fuel Pump:	
Type	Wesco pump
Discharge	11 mL (0.37 US oz.) or more for 2 seconds
Fuel Injectors:	
Type	KN-7
Nozzle Type	One spray type with 10 holes
Resistance	About 9.97 ~ 11.03 Ω at 20°C (68°F)
Main Throttle Sensor:	
Input Voltage	DC 4.75 ~ 5.25 V
Output Voltage	DC 0.585 ~ 0.615 V at idle throttle opening DC 3.7 ~ 3.9 V at full throttle opening
Resistance	4 ~ 6 kΩ
Inlet Air Pressure Sensor:	
Input Voltage	DC 4.75 ~ 5.25 V
Output Voltage	DC 2.87 ~ 2.93 V at standard atmospheric pressure (see this text for details)
Inlet Air Temperature Sensor:	
Output Voltage	About DC 2.25 ~ 2.50 V at inlet air temperature 20°C (32°F)
Resistance	5.4 ~ 6.6 kΩ at 0°C (32°F) 0.29 ~ 0.39 kΩ at 80°C (176°F) (for reference)
Water Temperature Sensor:	
Resistance	see Electrical System chapter
Output Voltage	About DC 2.80 ~ 2.97 V at 20°C (68°F)
Speed Sensor:	
Input Voltage	About DC 9 ~ 11 V
Output Voltage	Less than DC 0.6 V or over than DC 4.8 V at ignition switch ON and 0 km/h
Vehicle-down Sensor:	
Detection Angle	More than 60 ~ 70° for each bank
Input Voltage	DC 4.75 ~ 5.25 V
Output Voltage	With sensor tilted 60 ~ 70° or more right or left: DC 0.65 ~ 1.35 V With sensor arrow mark pointed up: DC 3.55 ~ 4.45 V
Subthrottle Sensor:	
Input Voltage	DC 4.75 ~ 5.25 V

Specifications

Item	Standard
Output Voltage	DC 0.48 ~ 0.52 V at subthrottle valve full close position DC 3.8 ~ 4.0 V at subthrottle valve full open position (for reference)
Resistance	4 ~ 6 kΩ
Subthrottle Valve Actuator:	
Resistance	About 5.2 ~ 7.8 Ω
Input Voltage	About DC 10.5 ~ 12.5 V, and then 0 V
Oxygen Sensor:	
Output Voltage (Rich)	DC 0.8 V or more
Output Voltage (Lean)	DC 0.24 V or more
Heater Resistance	6.7 ~ 10.5 Ω at 20°C (68°F)
Throttle Grip and Cables	
Throttle Grip Free Play	2 ~ 3 mm (0.08 ~ 0.12 in.)

3-20 FUEL SYSTEM (DFI)

Special Tools and Sealant

Oil Pressure Gauge, 5 kgf/cm²:

57001-125

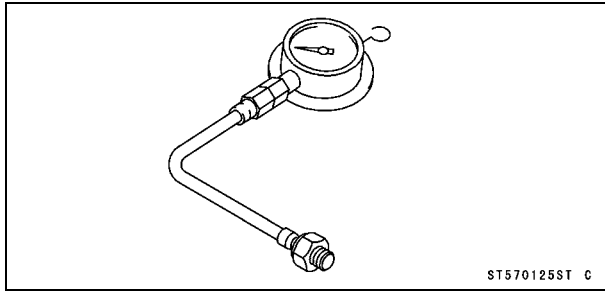

ST570125ST C

Needle Adapter Set:

57001-1457

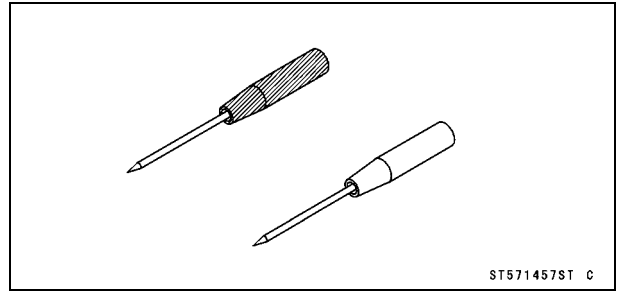

ST571457ST C

Jack:

57001-1238

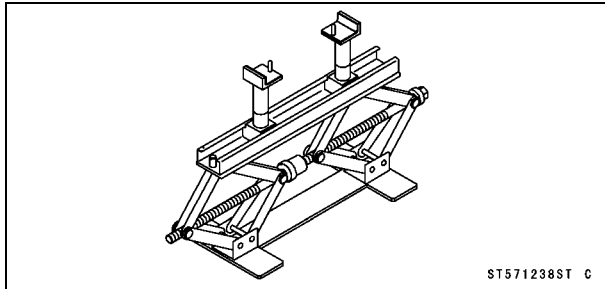

ST571238ST C

Throttle Sensor Setting Adapter:

57001-1538

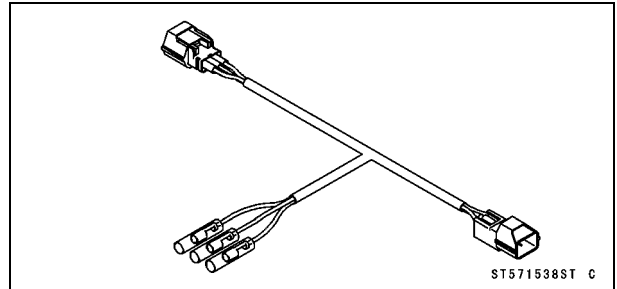

ST571538ST C

Hand Tester:

57001-1394

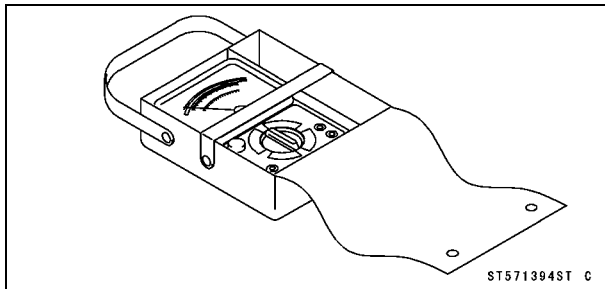

ST571394ST C

Fuel Pressure Gauge Adapter:

57001-1593

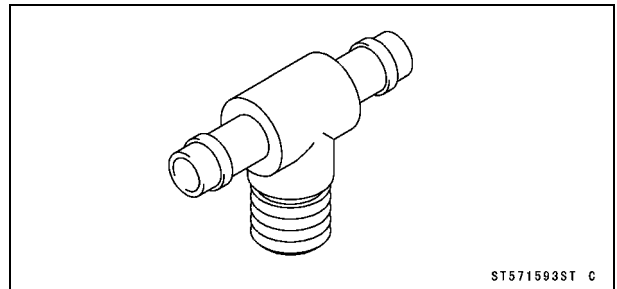

ST571593ST C

Throttle Sensor Setting Adapter #1:

57001-1400

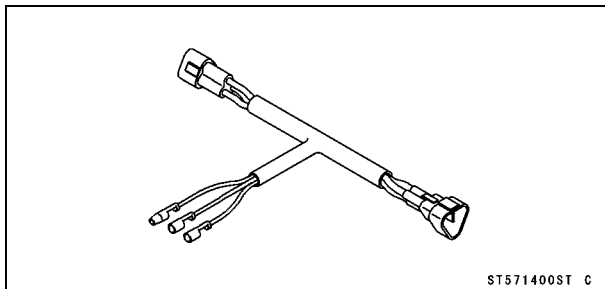

ST571400ST C

Fuel Hose:

57001-1607

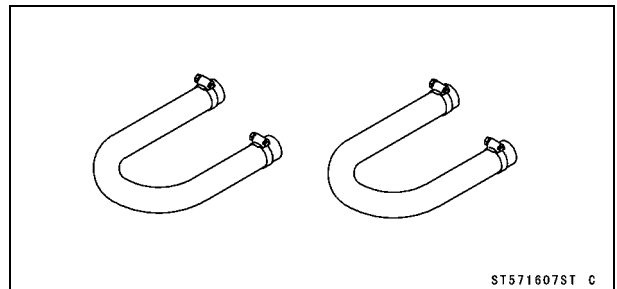

ST571607ST C

Peak Voltage Adapter:

57001-1415

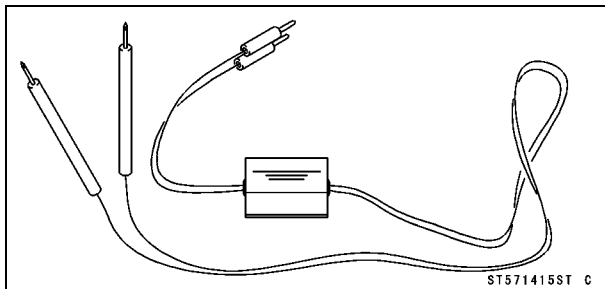

ST571415ST C

Measuring Adapter:

57001-1700

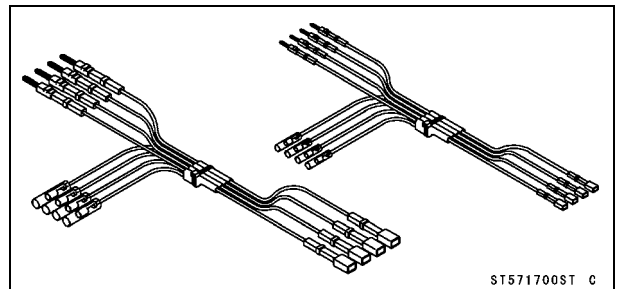

ST571700ST C

Special Tools and Sealant

Liquid Gasket, TB1211:
56019-120

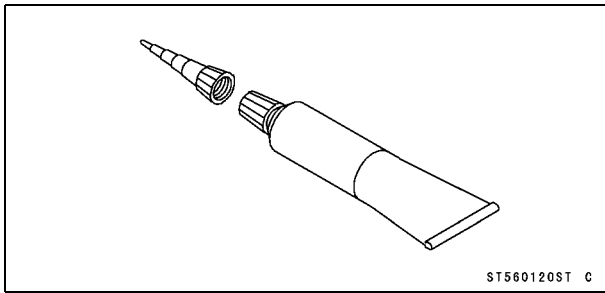

3-22 FUEL SYSTEM (DFI)

DFI Servicing Precautions

DFI Servicing Precautions

There are a number of important precautions that should be followed servicing the DFI system.

- This DFI system is designed to be used with a 12 V sealed battery as its power source. Do not use any other battery except for a 12 V sealed battery as a power source.
- Do not reverse the battery cable connections. This will damage the ECU.
- To prevent damage to the DFI parts, do not disconnect the battery cables or any other electrical connections when the ignition switch is ON, or while the engine is running.
- Take care not to short the leads that are directly connected to the battery positive (+) terminal to the chassis ground.
- When charging, remove the battery from the motorcycle. This is to prevent ECU damage by excessive voltage.
- Whenever the DFI electrical connections are to be disconnected, first turn off the ignition switch, and disconnect the battery (–) terminal. Do not pull the lead, only the connector. Conversely, make sure that all the DFI electrical connections are firmly reconnected before starting the engine.
- Connect these connectors until they click [A].

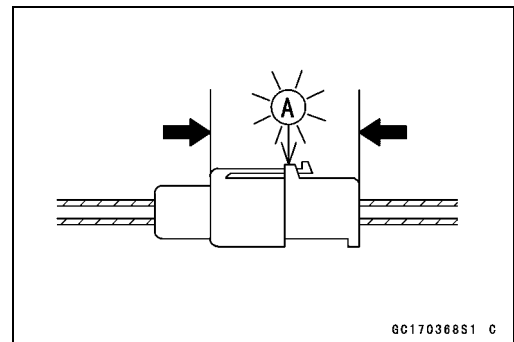

- Do not turn the ignition switch ON while any of the DFI electrical connectors are disconnected. The ECU memorizes service codes.
- Do not spray water on the electrical parts, DFI parts, connectors, leads and wiring.
- If a transceiver is installed on the motorcycle, make sure that the operation of the DFI system is not influenced by electric wave radiated from the antenna. Check operation of the system with the engine at idle. Locate the antenna as far as possible away from the ECU.
- When any fuel hose is disconnected, do not turn on the ignition switch. Otherwise, the fuel pump will operate and fuel will spout from the fuel hose.
- Do not operate the fuel pump if the pump is completely dry. This is to prevent pump seizure.
- Before removing the fuel system parts, blow the outer surfaces of these parts clean with compressed air.
- When any fuel hose is disconnected, fuel may spout out by residual pressure in the fuel line. Cover the hose joint with a piece of clean cloth to prevent fuel spillage.
- When installing the fuel hoses, avoid sharp bending, kinking, flattening or twisting, and run the fuel hoses with a minimum of bending so that the fuel flow will not be obstructed.
- Route the hoses according to Cable, Wire, and Hose Routing section in the Appendix chapter.
- To prevent corrosion and deposits in the fuel system, do not add to fuel any fuel antifreeze chemicals.

DFI Servicing Precautions

○If the motorcycle is not properly handled, the high pressure inside the fuel line can cause fuel to leak or the hose to burst. Remove the fuel tank (see Fuel Tank Removal) and check the fuel hose.

Fuel Inlet Hose [A]

Fuel Outlet Hose [B]

★Replace the fuel hose if any fraying, cracks or bulges are noticed.

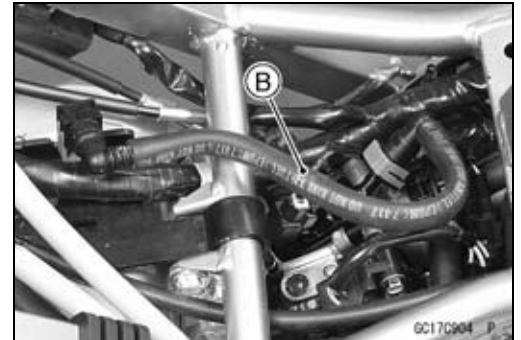
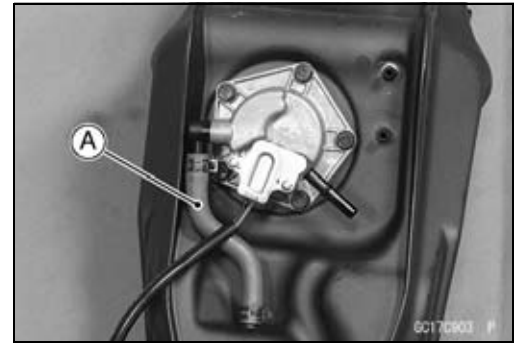

○To maintain the correct fuel/air mixture (F/A), there must be no inlet air leaks in the DFI system. Be sure to install the oil filler plug [A] after filling the engine oil.

Torque - Oil Filler Plug: Hand-tighten



3-24 FUEL SYSTEM (DFI)

Troubleshooting the DFI System

Outline

When an abnormality in the system occurs, the FI indicator LED (Light Emitting Diode) light goes on to alert the rider on the meter panel. In addition, the condition of the problem is stored in the memory of the ECU (Electronic Control Unit). With the engine stopped and turned in the self-diagnosis mode, the service code [A] is indicated by the number of times the FI indicator LED light blinks.

When due to a malfunction, the FI indicator LED light remains lit, ask the rider about the conditions [B] under which the problem occurred and try to determine the cause [C].

- First, conduct a self-diagnosis inspection and then a non-self-diagnosis inspection. The non-self-diagnosis items are not indicated by the FI indicator LED light. Don't rely solely on the DFI self-diagnosis function, use common sense.

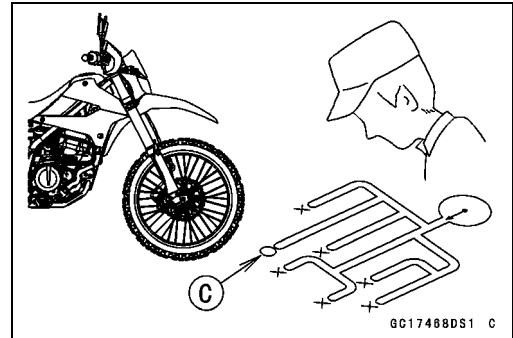
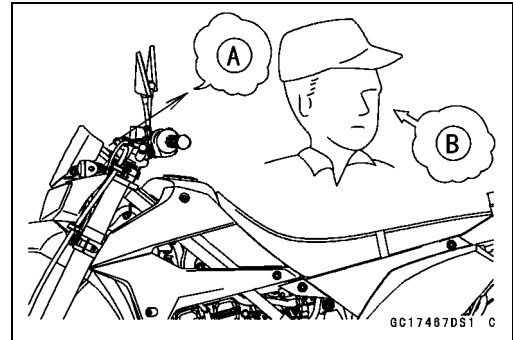

Even when the DFI system is operating normally, the FI indicator LED light [A] may light up under strong electrical interference. No repair needed. Turn the ignition switch OFF to stop the indicator light.

When the FI indicator LED light goes on and the motorcycle is brought in for repair, check the service codes.

When the repair has been done, the LED light doesn't go on. But the service codes stored in memory are not erased to preserve the problem history, and the LED light can display the codes in the self-diagnosis mode. The problem history is referred when solving unstable problems.

When the motorcycle is down, the vehicle-down sensor is turned OFF and the ECU shuts off the fuel injectors and ignition system. The FI indicator LED light blinks but the service code cannot be displayed. The ignition switch is left ON. If the starter button is pushed, the electric starter turns but the engine doesn't start. To start the engine again, raise the motorcycle, turn the ignition switch OFF, and then ON. The vehicle-down sensor is turned ON and the LED light goes OFF.

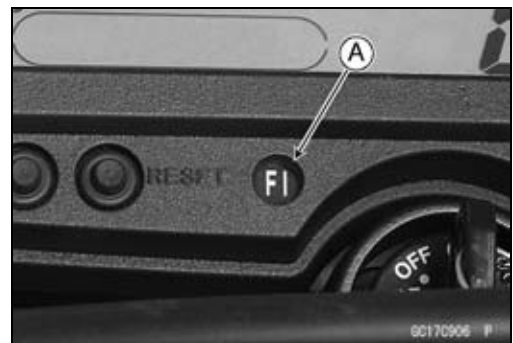

Troubleshooting the DFI System

- When checking the DFI parts, use a digital meter which can be read two decimal place voltage or resistance.
- The DFI part connectors [A] have seals [B], including the ECU. When measuring the input or output voltage with the connector joined, use the needle adapter set [C]. Insert the needle adapter inside the seal until the needle adapter reaches the terminal.

Special Tool - Needle Adapter Set: 57001-1457

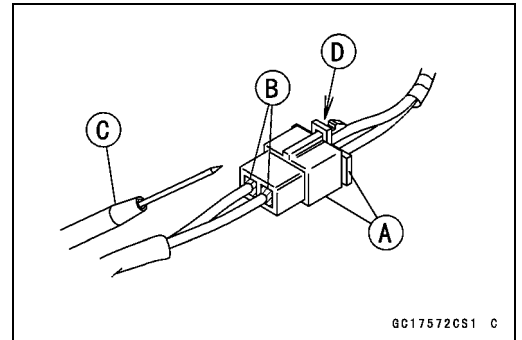

NOTICE

Insert the needle adapter straight along the terminal in the connector to prevent short-circuit between terminals.

- Make sure that measuring points are correct in the connector, noting the position of the lock [D] and the lead color before measurement. Do not reverse connections of a digital meter.
- Be careful not to short-circuit the leads of the DFI or electrical system parts by contact between adapters.
- Turn the ignition switch ON and measure the voltage with the connector joined.

NOTICE

Incorrect, reverse connection or short circuit by needle adapters could damage the DFI or electrical system parts.

- After measurement, remove the needle adapters and apply silicone sealant to the seals [A] of the connector [B] for waterproofing.

Sealant - Liquid Gasket, TB1211: 56019-120

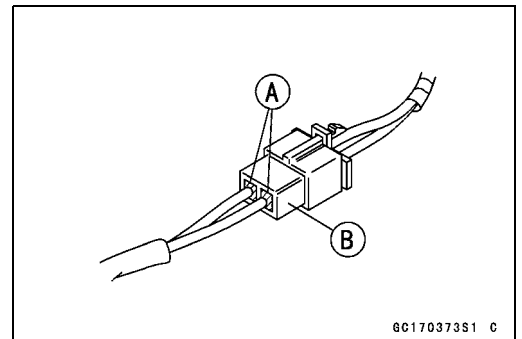

- Always check battery condition before replacing the DFI parts. A fully charged battery is a must for conducting accurate tests of the DFI system.
 - Trouble may involve one or in some cases all items. Never replace a defective part without determining what CAUSED the problem. If the problem was caused by some other item or items, they too must be repaired or replaced, or the new replacement part will soon fail again.
 - Measure coil winding resistance when the DFI part is cold (at room temperature).
 - Make sure all connectors in the circuit are clean and tight, and examine leads for signs of burning, fraying, short, etc. Deteriorated leads and bad connections can cause reappearance of problems and unstable operation of the DFI system.
- ★ If any wiring is deteriorated, replace the wiring.

3-26 FUEL SYSTEM (DFI)

Troubleshooting the DFI System

- Pull each connector [A] apart and inspect it for corrosion, dirt, and damage.
- ★ If the connector is corroded or dirty, clean it carefully. If it is damaged, replace it. Connect the connectors securely.
- Check the wiring for continuity.
- Use the wiring diagram to find the ends of the lead which is suspected of being a problem.
- Connect the hand tester between the ends of the leads.

Special Tool - Hand Tester: 57001-1394

- Set the tester to the $\times 1 \Omega$ range, and read the tester.
- ★ If the tester does not read 0Ω , the lead is defective. Replace the lead or the main harness or the subharness.
- If both ends of a harness [A] are far apart, ground [B] the one end [C], using a jumper lead [D] and check the continuity between the end [E] and the ground [F]. This enables to check a long harness for continuity. If the harness is open, repair or replace the harness.

- When checking a harness [A] for short circuit, open one end [B] and check the continuity between the other end [C] and ground [D]. If there is continuity, the harness has a short circuit to ground, and it must be repaired or replaced.

- Narrow down suspicious locations by repeating the continuity tests from the ECU connectors.
- ★ If no abnormality is found in the wiring or connectors, the DFI parts are the next likely suspects. Check the part, starting with input and output voltages. However, there is no way to check the ECU itself.
- ★ If an abnormality is found, replace the affected DFI part.
- ★ If no abnormality is found in the wiring, connectors, and DFI parts, replace the ECU.

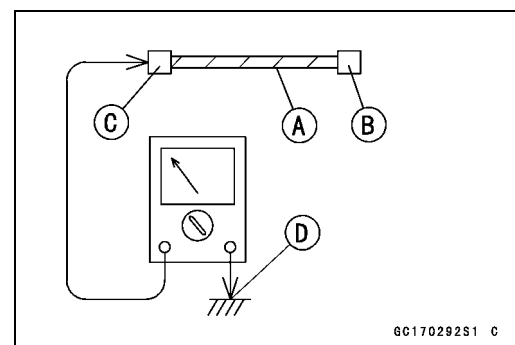
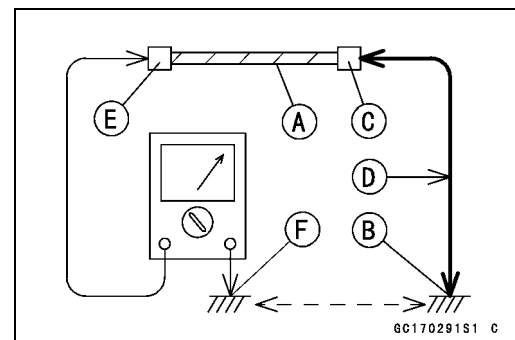
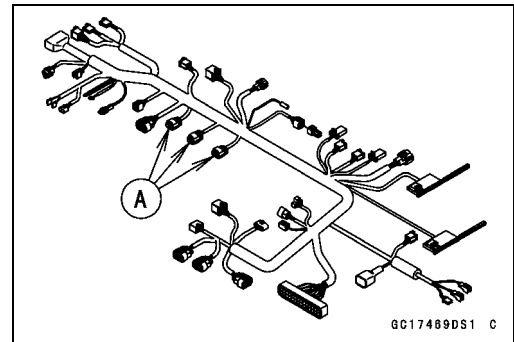

Troubleshooting the DFI System

DFI Diagnosis Flow Chart

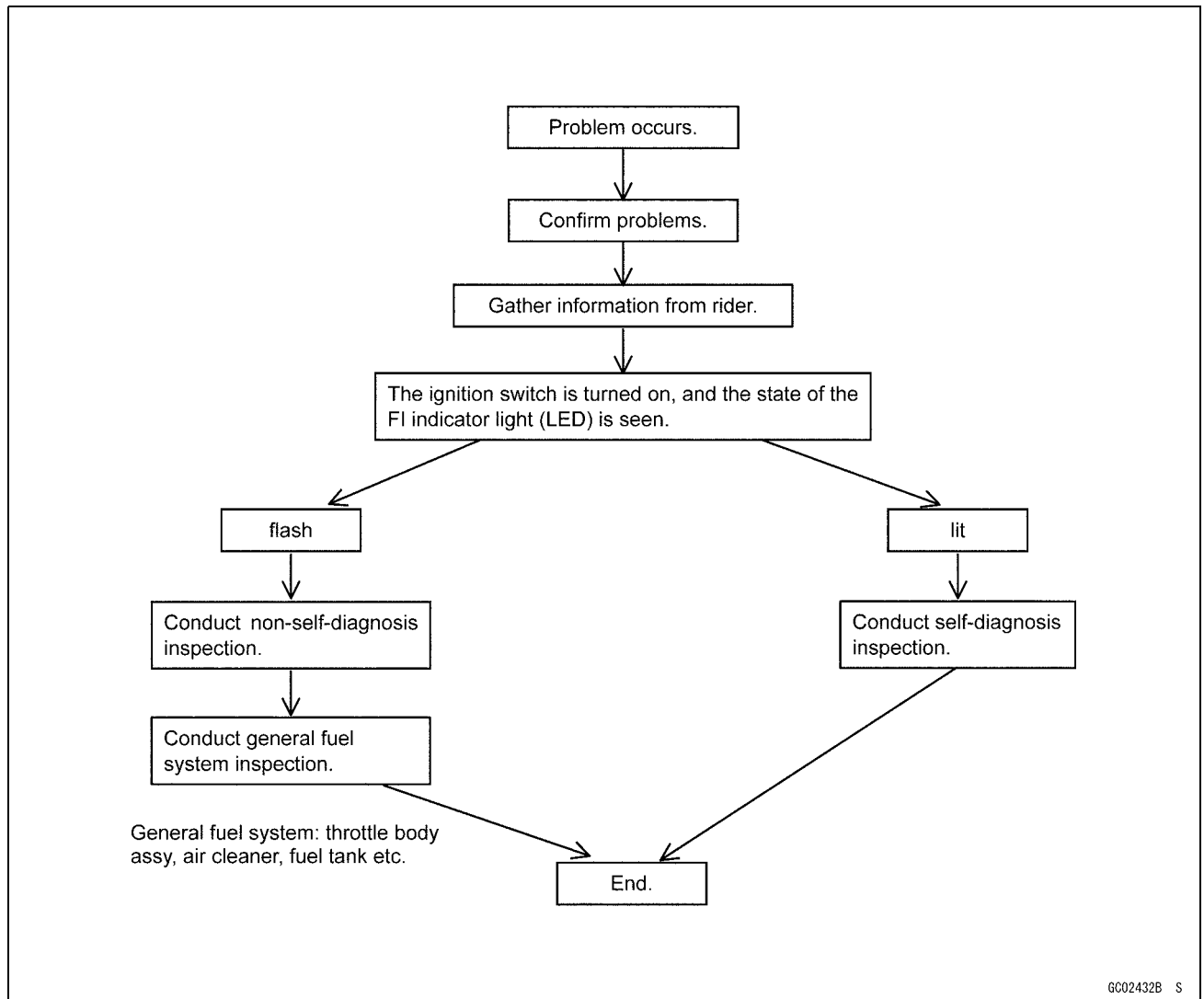

Inquiries to Rider

- Each rider reacts to problems in different ways, so it is important to confirm what kind of symptoms the rider has encountered.
- Try to find out exactly what problem occurred under exactly what conditions by asking the rider; knowing this information may help you reproduce the problem.
- The following sample diagnosis sheet will help prevent you from overlooking any areas, and will help you decide if it is a DFI system problem, or a general engine problem.

3-28 FUEL SYSTEM (DFI)

Troubleshooting the DFI System

Sample Diagnosis Sheet

Rider name	Registration No. (license plate No.)	Year of initial registration
Model	Engine No.	Frame No.
Date problem occurred		Mileage
Environment when problem occurred.		
Weather	<input type="checkbox"/> fine, <input type="checkbox"/> cloudy, <input type="checkbox"/> rain, <input type="checkbox"/> snow, <input type="checkbox"/> always, <input type="checkbox"/> other:	
Temperature	<input type="checkbox"/> hot, <input type="checkbox"/> warm, <input type="checkbox"/> cold, <input type="checkbox"/> very cold, <input type="checkbox"/> always	
Problem frequency Road	<input type="checkbox"/> chronic, <input type="checkbox"/> often, <input type="checkbox"/> once	
	<input type="checkbox"/> street, <input type="checkbox"/> highway, <input type="checkbox"/> mountain road (<input type="checkbox"/> uphill, <input type="checkbox"/> downhill), <input type="checkbox"/> bumpy, <input type="checkbox"/> pebble	
Altitude	<input type="checkbox"/> normal, <input type="checkbox"/> high (about 1000 m or more)	
Motorcycle conditions when problem occurred.		
FI indicator LED light	<input type="checkbox"/> light up immediately after ignition switch ON, and goes off after engine oil pressure is high enough (with engine running) (normal).	
	<input type="checkbox"/> lights up immediately after ignition switch ON, and stays on after engine oil pressure is high enough (with engine running) (DFI problem)	
	<input type="checkbox"/> lights up immediately after ignition switch ON, but goes off after about 10 seconds though engine oil pressure is high enough (with engine running) (DFI problem).	
	<input type="checkbox"/> unlights (LED light, ECU or its wiring fault).	
	<input type="checkbox"/> sometimes lights up (probably wiring fault).	
Starting difficulty	<input type="checkbox"/> starter motor not rotating.	
	<input type="checkbox"/> starter motor rotating but engine doesn't turn over.	
	<input type="checkbox"/> starter motor and engine don't turn over.	
	<input type="checkbox"/> no fuel flow (<input type="checkbox"/> no fuel in tank, <input type="checkbox"/> no fuel pump sound).	
	<input type="checkbox"/> engine flooded (do not crank engine with throttle opened, which promotes engine flooding).	
	<input type="checkbox"/> no spark.	
	<input type="checkbox"/> other:	
Engine stops	<input type="checkbox"/> right after starting.	
	<input type="checkbox"/> when opening throttle grip.	
	<input type="checkbox"/> when closing throttle grip.	
	<input type="checkbox"/> when moving off.	
	<input type="checkbox"/> when stopping the motorcycle.	
	<input type="checkbox"/> when cruising.	
	<input type="checkbox"/> other:	
Poor running at low speed	<input type="checkbox"/> very low fast idle speed.	
	<input type="checkbox"/> very low idle speed, <input type="checkbox"/> very high idle speed, <input type="checkbox"/> rough idle speed.	
	<input type="checkbox"/> battery voltage is low (charge the battery).	
	<input type="checkbox"/> spark plug loose (tighten it).	
	<input type="checkbox"/> spark plug dirty, broken, or gap maladjusted (adjust it).	
	<input type="checkbox"/> backfiring.	
	<input type="checkbox"/> afterfiring.	
	<input type="checkbox"/> hesitation when acceleration.	
	<input type="checkbox"/> engine oil viscosity too high.	
	<input type="checkbox"/> brake dragging.	

Troubleshooting the DFI System

	<input type="checkbox"/> engine overheating.
	<input type="checkbox"/> clutch slipping.
	<input type="checkbox"/> other:
Poor running or no power at high speed	<input type="checkbox"/> spark plug loose (tighten it).
	<input type="checkbox"/> spark plug dirty, broken, or gap maladjusted (remedy it).
	<input type="checkbox"/> spark plug incorrect (replace it).
	<input type="checkbox"/> knocking (fuel poor quality or incorrect).
	<input type="checkbox"/> brake dragging.
	<input type="checkbox"/> clutch slipping.
	<input type="checkbox"/> engine overheating.
	<input type="checkbox"/> engine oil level too high.
	<input type="checkbox"/> engine oil viscosity too high.
	<input type="checkbox"/> other:

3-30 FUEL SYSTEM (DFI)

DFI System Troubleshooting Guide

NOTE

- *This is not an exhaustive list, giving every possible cause for each problem listed. It is meant simply as a rough guide to assist the troubleshooting for some of the more common difficulties in DFI system.*
- *The ECU may be involved in the DFI electrical and ignition system troubles. If these parts and circuits are checked out good, be sure to check the ECU for ground and power supply. If the ground and power supply are checked good, replace the ECU.*

Engine Won't Turn Over

Symptoms or Possible Causes	Actions (chapter)
Neutral, starter lockout or sidestand switch trouble	Inspect each switch (see chapter 16).
Vehicle-down sensor OFF	Reinstall (see chapter 3).
Crankshaft sensor trouble	Inspect (see chapter 16).
Ignition coil shorted or not in good contact	Inspect or Reinstall (see chapter 16).
Ignition coil trouble	Inspect (see chapter 16).
Spark plug dirty, broken or gap maladjusted	Inspect and replace (see chapter 16).
Spark plug incorrect	Replace it with the correct plug (see chapter 2).
ECU ground and power supply trouble	Inspect (see chapter 3).
ECU trouble	Inspect (see chapter 3).
No or little fuel in tank	Supply fuel (see Owner's Manual).
Fuel injector trouble	Inspect and replace (see chapter 3).
Fuel pump not operating	Inspect (see chapter 3).
Fuel pump relay trouble	Inspect and replace (see chapter 3).
Fuel filter or pump screen clogged	Inspect and replace fuel pump (see chapter 3).
Fuel pressure regulator trouble	Inspect fuel pressure and replace fuel pump (see chapter 16).
Fuel line clogged	Inspect and repair (see chapter 3).

Poor Running at Low Speed

Symptoms or Possible Causes	Actions (chapter)
Spark weak:	
Ignition coil shorted or not in good contact	Inspect or reinstall (see chapter 16).
Ignition coil trouble	Inspect (see chapter 16).
Spark plug dirty, broken or gap maladjusted	Inspect and replace (see chapter 16).
Spark plug incorrect	Replace it with the correct plug (see chapter 2).
ECU trouble	Inspect (see chapter 3).
Fuel/air mixture incorrect:	
Little fuel in tank	Supply fuel (see Owner's Manual).
Air cleaner clogged, poorly sealed, or missing	Clean element or inspect sealing (see chapter 3).
Air cleaner duct loose	Reinstall (see chapter 3).
Throttle body assy holder loose	Reinstall (see chapter 3).
Fuel injector dust seal damage	Replace (see chapter 3).
Fuel injector O-ring damage	Replace (see chapter 3).
Fuel filter or pump screen clogged	Inspect and replace fuel pump (see chapter 3).
Fuel pressure regulator trouble	Inspect fuel pressure and replace fuel pump (see chapter 3).

DFI System Troubleshooting Guide

Symptoms or Possible Causes	Actions (chapter)
Fuel line clogged	Inspect and repair (see chapter 3).
Inlet air pressure sensor trouble	Inspect (see chapter 3).
Water temperature sensor trouble	Inspect (see chapter 3).
Inlet air temperature sensor trouble	Inspect (see chapter 3).
Main throttle sensor trouble	Inspect (see chapter 3).
Subthrottle sensor trouble	Inspect (see chapter 3).
Subthrottle valve actuator trouble	Inspect (see chapter 3).
Unstable (rough) idling:	
Fuel pressure too low or too high	Inspect (see chapter 3).
Fuel injector trouble	Inspect (see chapter 3).
Main throttle sensor trouble	Inspect (see chapter 3).
Subthrottle sensor trouble	Inspect (see chapter 3).
Subthrottle valve actuator trouble	Inspect (see chapter 3).
Inlet air pressure sensor trouble	Inspect (see chapter 3).
Water temperature sensor trouble	Inspect (see chapter 3).
Inlet air temperature sensor trouble	Inspect (see chapter 3).
Engine stalls easily:	
Spark plug dirty, broken or gap maladjusted	Inspect and replace (see chapter 16).
Ignition coil trouble	Inspect (see chapter 16).
Main throttle sensor trouble	Inspect (see chapter 3).
Subthrottle sensor trouble	Inspect (see chapter 3).
Subthrottle valve actuator trouble	Inspect (see chapter 3).
Inlet air pressure sensor trouble	Inspect (see chapter 3).
Water temperature sensor trouble	Inspect (see chapter 3).
Inlet air temperature sensor trouble	Inspect (see chapter 3).
Fuel pump trouble	Inspect (see chapter 3).
Fuel injector trouble	Inspect (see chapter 3).
Fuel pressure too low or too high	Inspect (see chapter 3).
Fuel pressure regulator trouble	Inspect fuel pressure and replace fuel pump (see chapter 16).
Fuel line clogged	Inspect and repair (see chapter 3).
Poor acceleration:	
Fuel pressure too low	Inspect (see chapter 3).
Water or foreign matter in fuel	Change fuel. Inspect and clean fuel system (see chapter 3).
Fuel filter or pump screen clogged	Inspect and replace fuel pump (see chapter 3).
Fuel pump trouble	Inspect (see chapter 3).
Fuel injector trouble	Inspect (see chapter 3).
Main throttle sensor trouble	Inspect (see chapter 3).
Subthrottle sensor trouble	Inspect (see chapter 3).
Subthrottle valve actuator trouble	Inspect (see chapter 3).
Inlet air pressure sensor trouble	Inspect (see chapter 3).
Water temperature sensor trouble	Inspect (see chapter 3).
Inlet air temperature sensor trouble	Inspect (see chapter 3).

3-32 FUEL SYSTEM (DFI)

DFI System Troubleshooting Guide

Symptoms or Possible Causes	Actions (chapter)
Spark plug dirty, broken or gap maladjusted	Inspect and replace (see chapter 16).
Ignition coil trouble	Inspect (see chapter 16).
Stumble:	
Fuel pressure too low	Inspect (see chapter 3).
Fuel injector trouble	Inspect (see chapter 3).
Main throttle sensor trouble	Inspect (see chapter 3).
Subthrottle sensor trouble	Inspect (see chapter 3).
Subthrottle valve actuator trouble	Inspect (see chapter 3).
Inlet air pressure sensor trouble	Inspect (see chapter 3).
Water temperature sensor trouble	Inspect (see chapter 3).
Inlet air temperature sensor trouble	Inspect (see chapter 3).
Surge:	
Unstable fuel pressure	Fuel pressure regulator trouble (Inspect and replace fuel pump) or kinked fuel line (Inspect and replace fuel pump) (see chapter 3).
Fuel injector trouble	Inspect (see chapter 3).
Water temperature sensor trouble	Inspect (see chapter 3).
Backfiring when deceleration:	
Spark plug dirty, broken or gap maladjusted	Inspect and replace (see chapter 16).
Fuel pressure too low	Inspect (see chapter 3).
Fuel pump trouble	Inspect (see chapter 3).
Main throttle sensor trouble	Inspect (see chapter 3).
Subthrottle sensor trouble	Inspect (see chapter 3).
Subthrottle valve actuator trouble	Inspect (see chapter 3).
Inlet air pressure sensor trouble	Inspect (see chapter 3).
Water temperature sensor trouble	Inspect (see chapter 3).
Inlet air temperature sensor trouble	Inspect (see chapter 3).
Air switching valve trouble	Inspect and replace (see chapter 16).
Air suction valve trouble	Inspect and replace (see chapter 5).
After fire:	
Spark plug burned or gap maladjusted	Replace (see chapter 16).
Fuel injector trouble	Inspect (see chapter 3).
Inlet air pressure sensor trouble	Inspect (see chapter 3).
Water temperature sensor trouble	Inspect (see chapter 3).
Inlet air temperature sensor trouble	Inspect (see chapter 3).
Other:	
Intermittent any DFI fault and its recovery	Check that DFI connectors are clean and tight, and examine leads for signs of burning or fraying (see chapter 3).

Poor Running or No Power at High Speed

Symptoms or Possible Causes	Actions (chapter)
Firing incorrect:	
Ignition coil shorted or not in good contact	Inspect or Reinstall (see chapter 16).
Ignition coil trouble	Inspect (see chapter 16).

DFI System Troubleshooting Guide

Symptoms or Possible Causes	Actions (chapter)
Spark plug dirty, broken or gap maladjusted	Inspect and replace (see chapter 16).
Spark plug incorrect	Replace it with the correct plug (see chapter 2).
ECU trouble	Inspect (see chapter 3).
Fuel/air mixture incorrect:	
Air cleaner clogged, poorly sealed, or missing	Clean element or inspect sealing (see chapter 3).
Air cleaner housing loose	Reinstall (see chapter 3).
Throttle body assy holder loose	Reinstall (see chapter 3).
Fuel injector dust seal damage	Replace (see chapter 3).
Water or foreign matter in fuel	Change fuel. Inspect and clean fuel system (see chapter 3).
Fuel injector O-ring damage	Replace (see chapter 3).
Fuel injector clogged	Inspect and repair (see chapter 3).
Fuel line clogged	Inspect and repair (see chapter 3).
Fuel pump operates intermittently and often DFI fuse blows.	Fuel pump bearings may wear. Replace the fuel pump (see chapter 3).
Fuel pump trouble	Inspect (see chapter 3).
Inlet air pressure sensor trouble	Inspect (see chapter 3).
Water temperature sensor trouble	Inspect (see chapter 3).
Inlet air temperature sensor trouble	Inspect (see chapter 3).
Main throttle sensor trouble	Inspect (see chapter 3).
Subthrottle sensor trouble	Inspect (see chapter 3).
Subthrottle valve actuator trouble	Inspect (see chapter 3).
Knocking:	
Fuel poor quality or incorrect	Fuel change (Use the gasoline recommended in the Owner's Manual).
Spark plug incorrect	Replace it with the correct plug (see chapter 2).
Ignition coil trouble	Inspect (see chapter 16).
ECU trouble	Inspect (see chapter 3).
Inlet air pressure sensor trouble	Inspect (see chapter 3).
Water temperature sensor trouble	Inspect (see chapter 3).
Inlet air temperature sensor trouble	Inspect (see chapter 3).
Miscellaneous:	
Subthrottle sensor trouble	Inspect (see chapter 3).
Subthrottle valve actuator trouble	Inspect (see chapter 3).
Speed sensor trouble	Inspect (see chapter 3).
Throttle valve will not fully open	Inspect throttle cables and lever linkage (see chapter 3).
Engine overheating - Water temperature sensor, crankshaft sensor or speed sensor trouble	(see Overheating of Troubleshooting Guide in chapter 17)
Air switching valve trouble	Inspect and replace (see chapter 16).
Air suction valve trouble	Inspect and replace (see chapter 5).
Exhaust Smokes Excessively:	
(Black smoke)	
Air cleaner element clogged	Clean element (see chapter 3).
Fuel pressure too high	Inspect (see chapter 3).

3-34 FUEL SYSTEM (DFI)

DFI System Troubleshooting Guide

Symptoms or Possible Causes	Actions (chapter)
Fuel injector trouble	Inspect (see chapter 3).
Water temperature sensor trouble	Inspect (see chapter 3).
Inlet air temperature sensor trouble	Inspect (see chapter 3).
(Brown smoke)	
Air cleaner housing loose	Reinstall (see chapter 3).
Fuel pressure too low	Inspect (see chapter 3).
Water temperature sensor trouble	Inspect (see chapter 3).
Inlet air temperature sensor trouble	Inspect (see chapter 3).

Self-Diagnosis

Self-diagnosis Outline

The self-diagnosis system has two modes and can be switched to another mode by grounding the self-diagnosis terminal.

User Mode

The ECU notifies the rider of troubles in DFI system and ignition system by lighting the FI indicator when DFI system and ignition system parts are faulty, and initiates fail-safe function. In case of serious troubles, the ECU stops the injection/ignition/starter motor operation.

Dealer Mode

The FI indicator light (LED) emits service code(s) to show the problem(s) which the DFI system, and ignition system has at the moment of diagnosis.

Self-diagnosis Procedures

○When a problem occurs with the DFI system and ignition system, the FI indicator light (LED) [A] goes on.

NOTE

- Use a fully charged battery when conducting self-diagnosis. Otherwise, the light (LED) blinks very slowly or doesn't blink.
- Keep the self-diagnosis terminal grounded during self-diagnosis, with an auxiliary lead.

- Remove the seat (see Seat Removal in the Frame chapter).
- Ground the self-diagnosis terminal [A] (O/BK lead) to the battery (-) terminal or battery (-) lead connector, using a wire.

- Turn on the ignition switch.
- Connect an auxiliary lead [E] to the self-diagnosis terminal [G] for grounding.
- To enter the self-diagnosis dealer mode, ground [A] the self-diagnosis indicator terminal to the battery (-) terminal for more than 2 seconds [C], and then keep it grounded continuously [D].
- Count the blinks of the light (LED) to read the service code. Keep the auxiliary lead ground until you finish reading the service code.

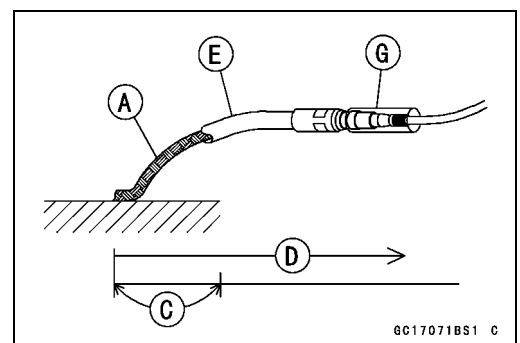
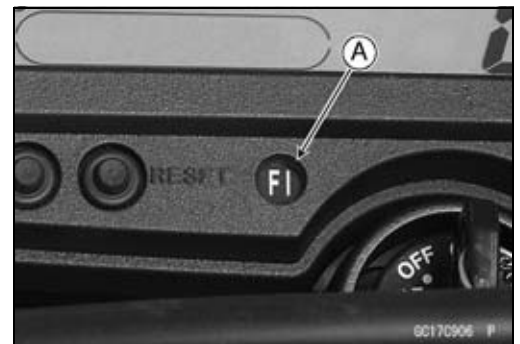

3-36 FUEL SYSTEM (DFI)

Self-Diagnosis

Self-Diagnosis Flow Chart

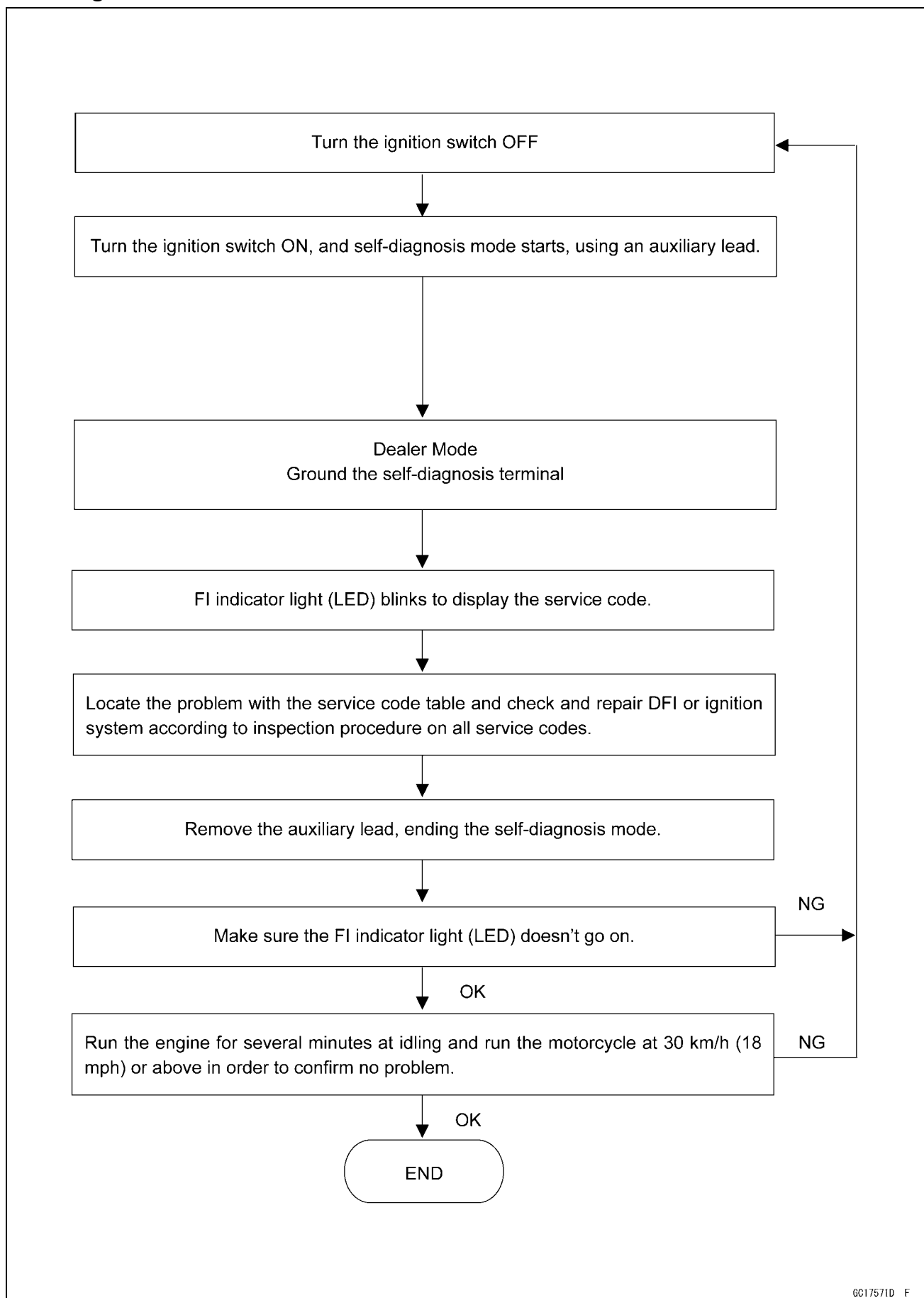

Self-Diagnosis

How to Read Service Codes

- Service codes are shown by a series of long and short blinks of the FI indicator light (LED) as shown below.
- Read 10th digit and unit digit as the FI indicator light (LED) blinks.
- When there are a number of problems, all the service codes can be stored and the display will begin starting from the lowest number service code in the numerical order. Then after completing all codes, the display is repeated until the self-diagnosis indicator terminal is open.
- If there is no problem, no code and flash.
- For example, if two problems occurred in the order of 21, 12, the service codes are displayed from the lowest number in the order listed.
(12 → 21) → (12 → 21) → ··· (repeated)

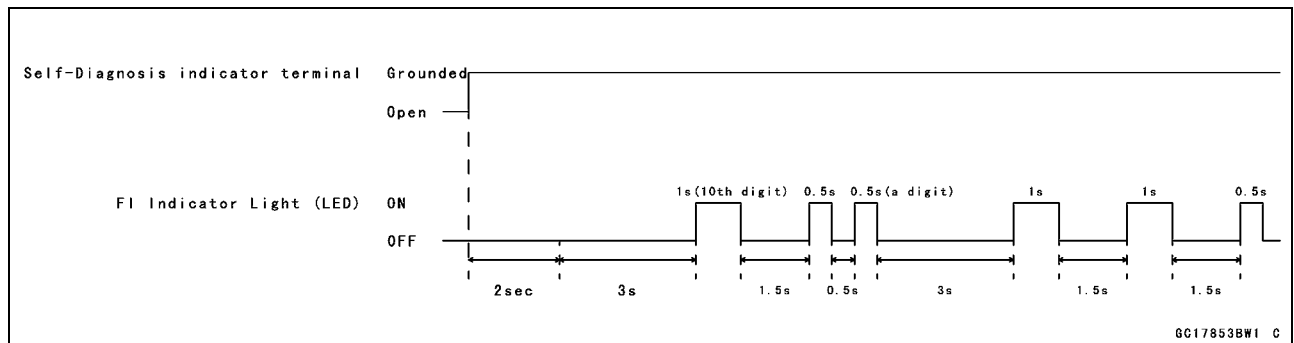

- If the problem is with the following parts, the ECU cannot memorize these problems, the FI indicator light (LED) doesn't go on, and no service codes can be displayed.
FI Indicator Light (LED)
Fuel Pump Relay Disconnect
ECU Power Source Wiring and Ground Wiring (see ECU Power Supply Inspection)

















How to Erase Service Codes

- Even if the ignition switch is turned OFF, the battery or the ECU are disconnected or the problem is solved, all service codes remain in the ECU.
- Refer to the Service Code Clearing Procedure for the service code erasure.

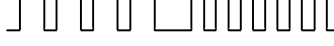
3-38 FUEL SYSTEM (DFI)

Self-Diagnosis

Service Code Table

Service Code	FI Indicator Light (LED)	Problems
11		Main throttle sensor malfunction, wiring open or short
12		Inlet air pressure sensor malfunction, wiring open or short
13		Inlet air temperature sensor malfunction, wiring open or short
14		Water temperature sensor malfunction, wiring open or short
21		Crankshaft sensor malfunction, wiring open or short
24		Speed sensor malfunction, wiring open or short
31		Vehicle-down sensor, malfunction, wiring open or short
32		TH and EUR Models Subthrottle sensor malfunction, wiring open or short
		IN Model Subthrottle valve actuator malfunction, wiring open or short
33		Oxygen sensor inactivation, wiring open or short
41		Injector malfunction, wiring open or short
46		Fuel pump relay malfunction, cling
51		Ignition coil malfunction, wiring open or short
56		Radiator fan relay malfunction, wiring open or short
62		TH and EUR Models Subthrottle valve actuator malfunction, wiring open or short
		IN Model Subthrottle sensor malfunction, wiring open or short
64		Air switching valve malfunction, wiring open or short
67		Oxygen sensor heater malfunction, wiring open or short

Self-Diagnosis

Notes:

- The ECU may be involved in these problems. If all the parts and circuits checked out good, be sure to check the ECU for ground and power supply. If the ground and power supply are checked good, replace the ECU.
- When no service code is displayed, the electrical parts of the DFI system has no fault, and the mechanical parts of the DFI system and the engine are suspect.

3-40 FUEL SYSTEM (DFI)

Self-Diagnosis

Backups

○The ECU takes the following measures to prevent engine damage when the DFI or the ignition system parts have troubles.

Service Codes	Parts	Output Signal Usable Range or Criteria	Backups by ECU
11	Main Throttle Sensor	Main Throttle Sensor Output Voltage 0.410 ~ 4.375 V	If the main throttle sensor system fails (the signal is out of the usable range, wiring short or open), the ECU locks ignition timing into the ignition timing at closed throttle position and sets the DFI in the D-J method. Also, the main throttle sensor system and inlet air pressure fails, the ECU locks ignition timing into the ignition timing at closed throttle position and sets the DFI in the α -N method.
12	Inlet Air Pressure Sensor	Inlet Air Pressure (absolute) $P_v = 13.3 \text{ kPa} \sim 120 \text{ kPa}$	If the inlet air pressure sensor system fails (the signal P_v is out of the usable range, wiring short or open), the ECU sets the DFI in the α -N method.
13	Inlet Air Temperature Sensor	Inlet Air Temperature $T_a = -30^\circ\text{C} \sim +120^\circ\text{C}$	If the inlet air temperature sensor fails (the signal is out of the usable range, wiring short or open), the ECU sets T_a at 40°C .
14	Water Temperature Sensor	Water Temperature $T_w = -30^\circ\text{C} \sim +120^\circ\text{C}$	If the water temperature sensor system fails (the signal is out of the usable range, wiring short or open), the ECU sets T_w at 80°C .
21	Crankshaft Sensor	Crankshaft sensor must send 18 signals (output signal) to the ECU at the one cranking.	TH and EUR Models If the crankshaft sensor generates other than 18 signals, the engine stops by itself (ECU detects the sensor failure only when the throttle opening is 15° or less).
			IN Model ECU only shows the service code (ECU detects the sensor failure only when the throttle opening is 15° or less).
24	Speed Sensor	Speed sensor must send 8 signals (output signal) to the ECU at the one rotation of the transmission gear. The gear position is decided by the signal of the speed sensor.	If the speed sensor system fails (no signal, wiring short or open), the speedometer shows 0, and the ECU sets the low (1) gear position.
31	Vehicle-down Sensor	Vehicle-down Sensor Output Voltage (signal) $V_d = 0.65 \text{ V} \sim 4.45 \text{ V}$	TH and EUR Models If the vehicle-down sensor system has failures, the ECU shuts off the fuel system and the ignition system.
			IN Model ECU does not backup.

Self-Diagnosis

Service Codes	Parts	Output Signal Usable Range or Criteria	Backups by ECU
32	Subthrottle Sensor	Subthrottle Sensor Output Voltage 0.35 V ~ 4.90 V	TH and EUR Models If the subthrottle sensor system fails (the signal is out of the usable range, wiring short or open), the actuator locks subthrottle valve at full open position.
	Subthrottle Valve Actuator	The actuator operates open and close of the subthrottle valve by the pulse signal from the ECU.	IN Model If the subthrottle valve actuator fails (the signal is out of the usable range, wiring short or open), the ECU stops the signal to the subthrottle valve.
33	Oxygen Sensor	The oxygen sensor is active and sensor must send signals (output voltage) continuously to the ECU.	If the oxygen sensor is not activated, the ECU stops oxygen sensor feedback mode.
41	Fuel Injector	In succession pulse is input to ECU.	If the injector break down and does not output for 0.8 seconds or more, wiring short or open, the ECU stops the signal input to injector and the fuel delivery to cylinder is stopped.
46	Fuel Pump Relay	Supply Voltage DC 11 V ~ 15 V When relay power supply is off, fuel pump relay is off.	ECU stops the operation of fuel injector.
51	Ignition Coil	The ignition coil primary winding must send signals (output voltage) continuously to the ECU.	TH and EUR Models If the ignition primary winding has failures (no signal, wiring short or open), the ECU shuts off the injector to stop fuel to the cylinder, through the engine keeps running (When the meter assy fails, the ECU detects the ignition coil failure only the meter lead connector is disconnected).
			IN Model ECU detects the ignition coil failure only when the meter lead connector is disconnected.
56	Radiator Fan Relay	When the relay OFF condition, the fan relay is OFF	ECU does not backup.
62	Subthrottle Valve Actuator	The actuator operates open and close of the subthrottle valve by the pulse signal from the ECU.	TH and EUR Models If the subthrottle valve actuator fails (the signal is out of the usable range, wiring short or open), the ECU stops the signal to the subthrottle valve.
	Subthrottle Sensor	Subthrottle Sensor Output Voltage 0.35 V ~ 4.90 V	IN Model If the subthrottle sensor system fails (the signal is out of the usable range, wiring short or open), the actuator locks subthrottle valve at full open position.

3-42 FUEL SYSTEM (DFI)

Self-Diagnosis

Service Codes	Parts	Output Signal Usable Range or Criteria	Backups by ECU
64	Air Switching Valve	The air switching valve solenoid opens and shuts the air switching valve according to the signal from the ECU.	ECU does not backup.
67	Oxygen Sensor Heater	The oxygen sensor heater raise temperature of the sensor for its earlier activation.	If the oxygen sensor heater fails (wiring short or open), the ECU stops the current to the heater.

Note:

- (1) D-J Method and α - N Method: When the engine load is light like at idling or low speed, the ECU determines the injection quantity by calculating from the throttle vacuum (inlet air pressure sensor output voltage) and engine speed (crankshaft sensor output voltage). This method is called D-J method (low-speed mode). As the engine speed increases, and the engine load turns middle to heavy, the ECU determines the injection quantity by calculating from the throttle opening (throttle sensor output voltage) and the engine speed. This method is called α - N method (high-speed mode).

Main Throttle Sensor (Service Code 11)

The main throttle sensor is a rotating variable resistor that change output voltage according to throttle operating. The ECU senses this voltage change and determines fuel injection quantity, and ignition timing according to engine rpm, and throttle opening.

Input Terminal [A]

Output Terminal [B]

Ground Terminal [C]

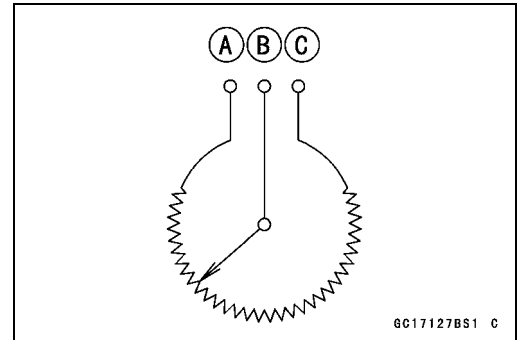

Main Throttle Sensor Removal/Adjustment

NOTICE

Do not remove or adjust the main throttle sensor [A] since it has been adjusted and set with precision at the factory.

Never drop the throttle body assy especially on a hard surface. Such a shock to the main throttle sensor can damage it.



Main Throttle Sensor Input Voltage Inspection

NOTE

○Be sure the battery is fully charged.

- Turn the ignition switch OFF.
- Disconnect the main throttle sensor connector and connect the harness adapter [A] between these connectors.

Special Tool - Throttle Sensor Setting Adapter: 57001-1538

- Connect a digital meter to the harness adapter leads.

Main Throttle Sensor Input Voltage

Connections to Adapter:

Digital Meter (+) → BK (sensor BL) lead

Digital Meter (-) → W (sensor BR/BK) lead

- Measure the input voltage with the engine stopped and with the connector joined.
- Turn the ignition switch ON.

Input Voltage

Standard: DC 4.75 ~ 5.25 V

- Turn the ignition switch OFF.
- ★ If the reading is within the standard, check the output voltage (see Main Throttle Sensor Output Voltage Inspection).



3-44 FUEL SYSTEM (DFI)

Main Throttle Sensor (Service Code 11)

★ If the reading is out of the standard, remove the ECU and check the wiring for continuity between main harness connectors.

○ Disconnect the ECU and sensor connectors.

Wiring Inspection

ECU Connector [A] ↔

Main Throttle Sensor Connector [B]

BL lead (ECU terminal 13) [C]

BR/BK lead (ECU terminal 24) [D]

★ If the wiring is good, check the ECU for its ground and power supply (see ECU Power Supply Inspection).

★ If the ground and power supply are good, replace the ECU (see ECU Removal/Installation).

Main Throttle Sensor Output Voltage Inspection

● Measure the output voltage at the main throttle sensor in the same way as input voltage inspection, note the following.

○ Disconnect the main throttle sensor connector and connect the harness adapter [A] between these connectors.

Special Tool - Throttle Sensor Setting Adapter: 57001-1538

Main Throttle Sensor Output Voltage

Connections to Adapter:

Digital Meter (+) → R (sensor LB) lead

Digital Meter (-) → W (sensor BR/BK) lead

- Start the engine and warm it up thoroughly.
- Check idle speed to ensure the throttle opening is correct.

Idle Speed

Standard: 1 300 ±50 r/min (rpm)

★ If the idle speed is out of the specified range, adjust it (see Idle Speed Inspection in the Periodic Maintenance chapter).

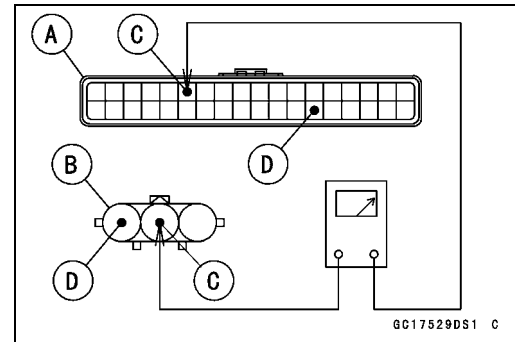

Main Throttle Sensor (Service Code 11)

- Turn the ignition switch OFF.
- Measure the output voltage with the engine stopped and with the connector joined.
- Turn the ignition switch ON.

Output Voltage

Standard: DC 0.585 ~ 0.615 V at idle throttle opening

DC 3.7 ~ 3.9 V at full throttle opening (for reference)

NOTE

- Open the throttle, confirm the output voltage will be raise.
- The standard voltage refers to the value when the voltage reading at the Input Voltage Inspection shows 5 V exactly.
- When the input voltage reading shows other than 5 V, derive a voltage range as follows.

Example:

In the case of a input voltage of 4.75 V.

$$0.585 \times 4.75 \div 5.00 = 0.556 \text{ V}$$

$$0.615 \times 4.75 \div 5.00 = 0.584 \text{ V}$$

Thus, the valid range is 0.556 ~ 0.584 V

- Turn the ignition switch OFF.
- ★ If the reading is out of the standard, check the main throttle sensor resistance (see Main Throttle Sensor Resistance Inspection).
- ★ If the reading is within the standard, remove the ECU and check the wiring for continuity between main harness side connectors.
- Disconnect the ECU and sensor connectors.

Wiring Inspection

ECU Connector [A] ↔

Main Throttle Sensor Connector [B]

LB lead (ECU terminal 5) [C]

BR/BK lead (ECU terminal 24) [D]

- ★ If the wiring is good, check the ECU for its ground and power supply (see ECU Power Supply Inspection).
- ★ If the ground and power supply are good, replace the ECU (see ECU Removal/Installation).

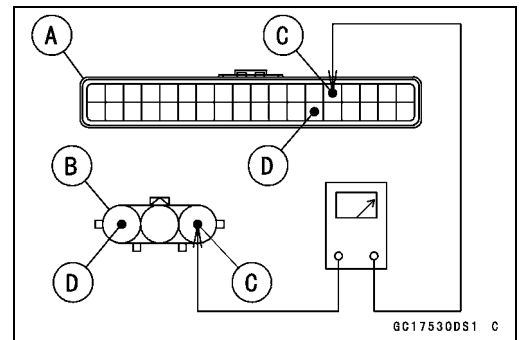

3-46 FUEL SYSTEM (DFI)

Main Throttle Sensor (Service Code 11)

Main Throttle Sensor Resistance Inspection

- Disconnect the main throttle sensor connector.
- Connect a harness adapter [A] to the main throttle sensor.

Special Tool - Throttle Sensor Setting Adapter: 57001-1538

Main Throttle Sensor Resistance

Connections to Adapter:

Digital Meter (+) → BK (sensor BL) lead

Digital Meter (-) → W (sensor BR/BK) lead

Standard: 4 ~ 6 kΩ

- ★ If the reading is out of the standard, replace the throttle body assy.
- ★ If the reading is within the standard, but the problem still exists, replace the ECU (see ECU Removal/Installation).

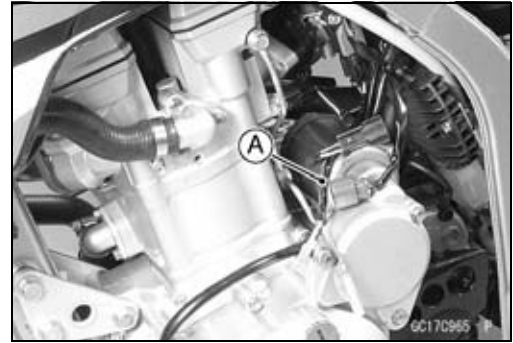

Main Throttle Sensor Circuit

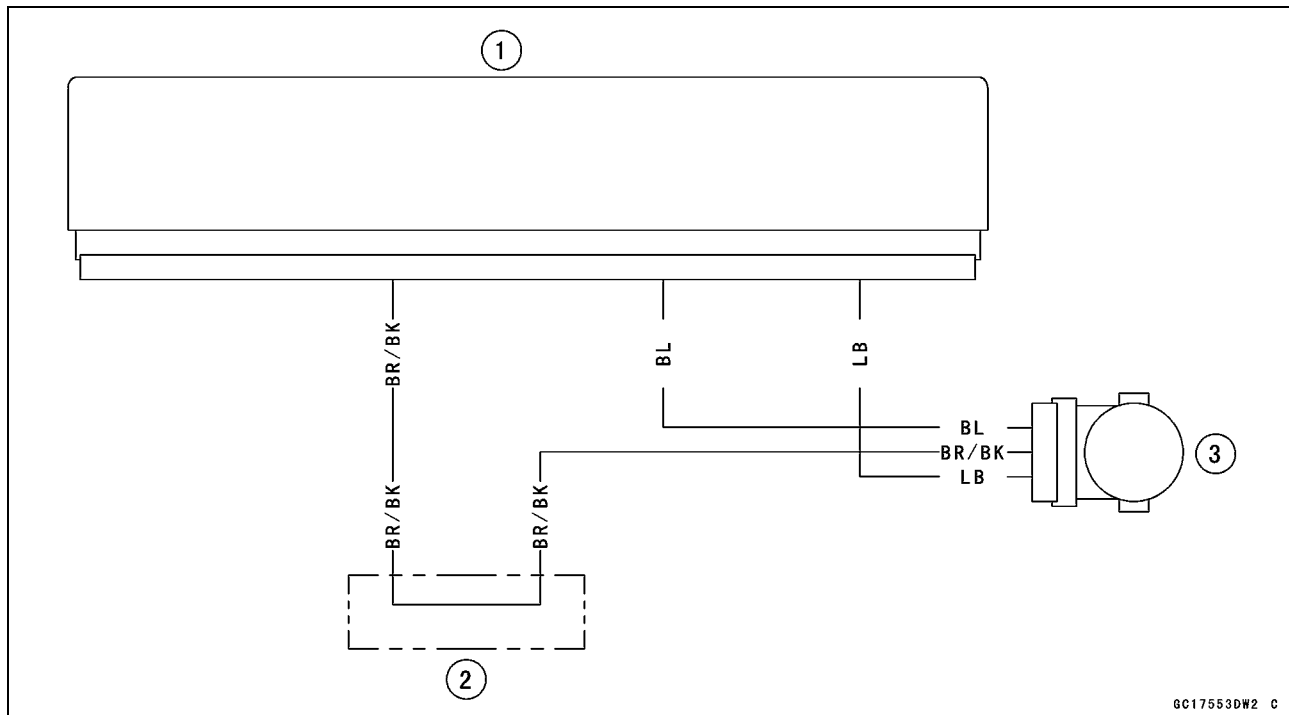

1. ECU
2. Water-proof Joint
3. Main Throttle Sensor

GC17553DW2 C

Inlet Air Pressure Sensor (Service Code 12)

Inlet Air Pressure Sensor Removal

NOTICE

Never drop the inlet air pressure sensor especially on a hard surface. Such a shock to the sensor can damage it.

- Remove:
 - Fuel Tank (see Fuel Tank Removal)
 - Inlet Air Pressure Sensor Connector [A]
 - Screw [B]
 - Plate [C]
- Remove the inlet air pressure sensor [A] from the throttle body assy.

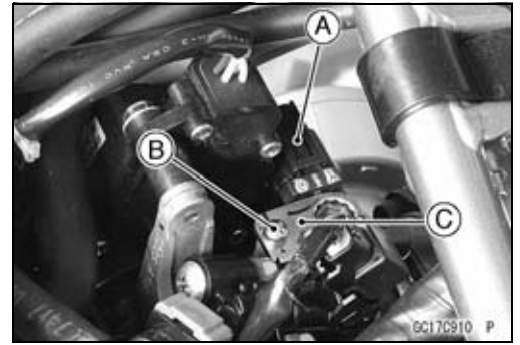

Inlet Air Pressure Sensor Installation

- Replace the O-ring [A] with a new one.
- Install the inlet air pressure sensor [A] to the throttle body assy.
- Install the plate so that fit the projection [B] on the plate and hollow [C] on the throttle body assy.

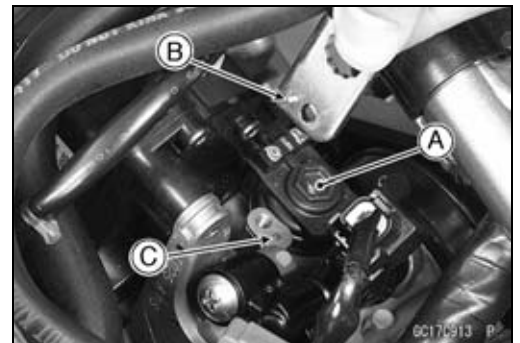

3-48 FUEL SYSTEM (DFI)

Inlet Air Pressure Sensor (Service Code 12)

- Tighten the screw [A] securely.
- Connect the inlet air pressure sensor connector [B].

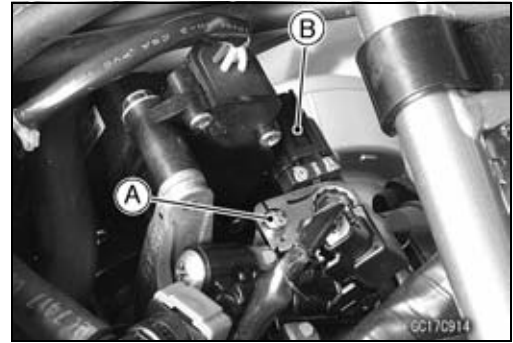

Inlet Air Pressure Sensor Input Voltage Inspection

NOTE

○Be sure the battery is fully charged.

- Turn the ignition switch OFF.
- Disconnect the inlet air pressure sensor connector and connect the harness adapter [A] between these connectors.

Main Harness [B]

Inlet Air Pressure Sensor [C]

Special Tool - Measuring Adapter: 57001-1700

- Connect a digital meter [D] to the harness adapter leads.

Inlet Air Pressure Sensor Input Voltage

Connections to Adapter:

Digital Meter (+) → R (sensor BL) lead

Digital Meter (-) → BK (sensor BR/BK) lead

- Measure the input voltage with the engine stopped and with the connector joined.
- Turn the ignition switch ON.

Input Voltage

Standard: DC 4.75 ~ 5.25 V

- Turn the ignition switch OFF.
 - ★ If the reading is within the standard, check the output voltage (see Inlet Air Pressure Sensor Output Voltage Inspection).
 - ★ If the reading is out of the standard, remove the ECU and check the wiring for continuity between main harness connectors.
- Disconnect the ECU and sensor connectors.

Wiring Inspection

ECU Connector [A] ↔

Inlet Air Pressure Sensor Connector [B]

BL lead (ECU terminal 13) [C]

BR/BK lead (ECU terminal 24) [D]

- ★ If the wiring is good, check the ECU for its ground and power supply (see ECU Power Supply Inspection).
- ★ If the ground and power supply are good, replace the ECU (see ECU Removal/Installation).

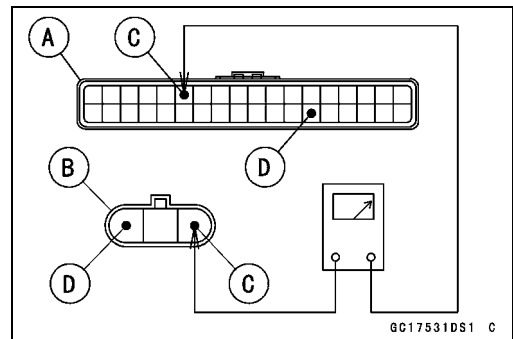
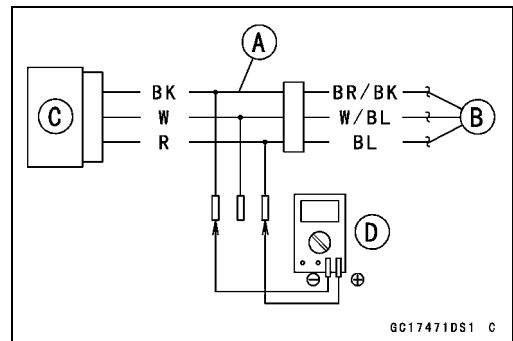

Inlet Air Pressure Sensor (Service Code 12)

Inlet Air Pressure Sensor Output Voltage Inspection

- Measure the output voltage at the inlet air pressure sensor in the same way as input voltage inspection, note the following.
- Disconnect the inlet air pressure sensor connector and connect the harness adapter [A] between these connectors.
 - Main Harness [B]
 - Inlet Air Pressure Sensor [C]
 - Digital Meter [D]

Special Tool - Measuring Adapter: 57001-1700

Inlet Air Pressure Sensor Output Voltage Connections to Adapter:

- Digital Meter (+) → W (sensor W/BL) lead
- Digital Meter (-) → BK (sensor BR/BK) lead

- Measure the output voltage with the engine stopped and with the connector joined.
- Turn the ignition switch ON.

Output Voltage

Usable Range: DC 2.87 ~ 2.93 V at standard atmospheric pressure (101.32 kPa, 76 cmHg)

NOTE

- The output voltage changes according to local atmospheric pressure.
- Turn the ignition switch OFF.
- ★ If the reading is out of the usable range, replace the sensor.
- ★ If the reading is within the usable range, remove the ECU and check the wiring for continuity between main harness connector.
- Disconnect the ECU and sensor connectors.

Wiring Inspection

- ECU Connector [A] ↔
- Inlet Air Pressure Sensor Connector [B]
- W/BL lead (ECU terminal 6) [C]
- BR/BK lead (ECU terminal 24) [D]

- ★ If the reading is within the usable range, check the ECU for its ground and power supply (see ECU Power Supply Inspection).
- ★ If the ground and power supply are good, replace the ECU (see ECU Removal/Installation).

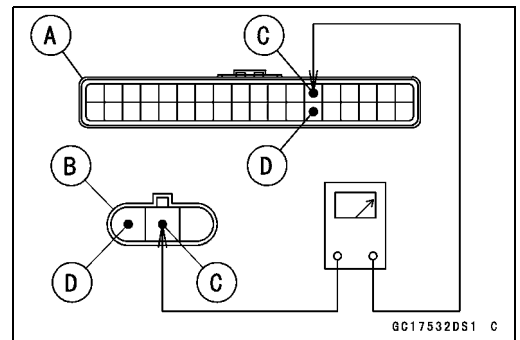
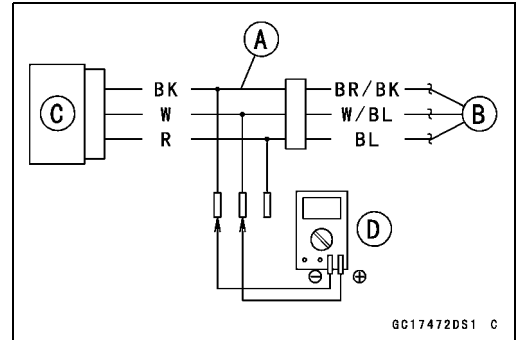

3-50 FUEL SYSTEM (DFI)

Inlet Air Pressure Sensor (Service Code 12)

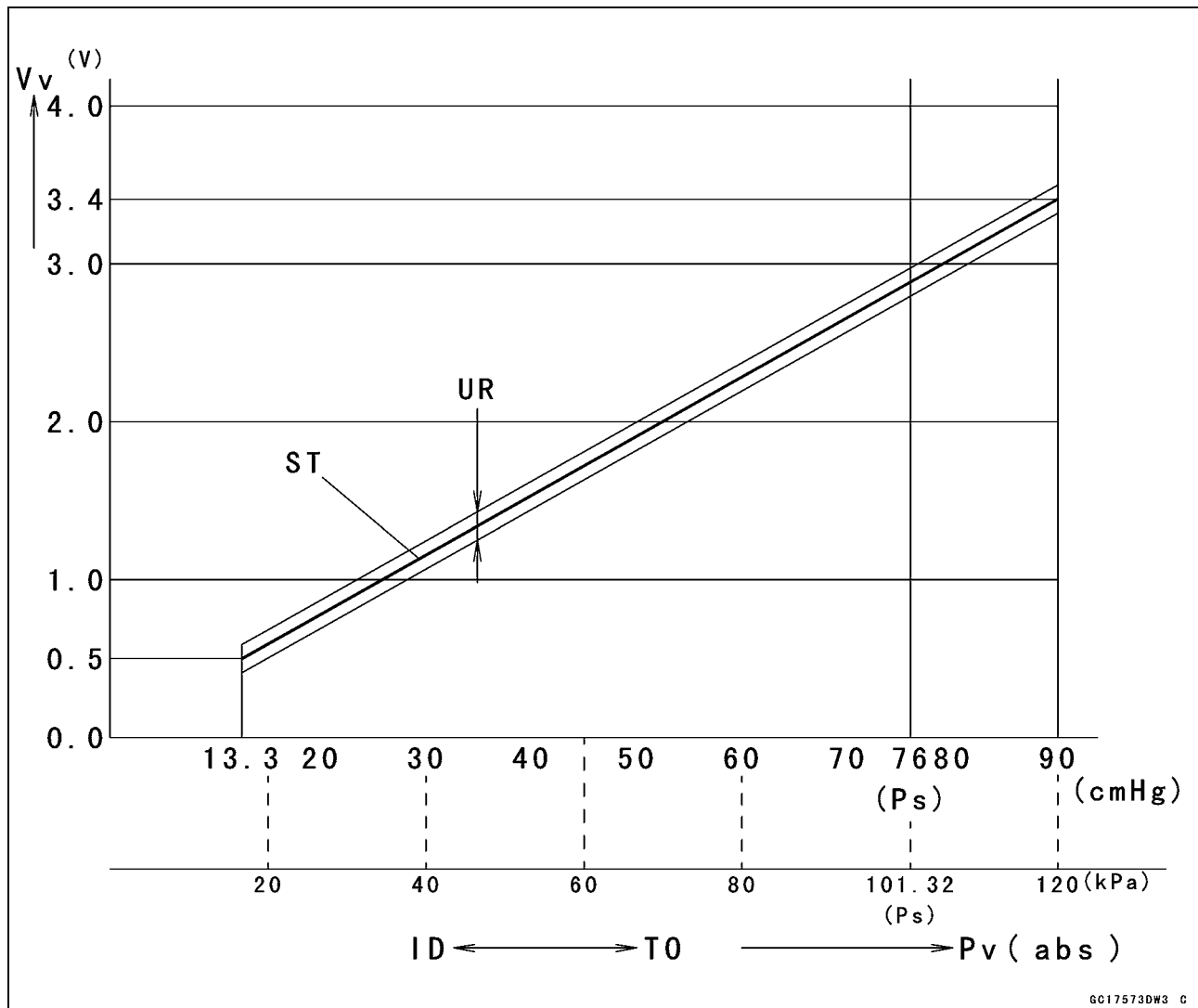

GC17573DW3 C

ID: Idling

Ps: Standard Atmospheric Pressure (Absolute)

Pv: Throttle Vacuum Pressure (Absolute)

ST: Standard of Sensor Output Voltage (V)

TO: Throttle Full Open

UR: Usable Range of Sensor Output Voltage (V)

Vv: Inlet Air Pressure Sensor Output Voltage (V) (Digital Meter Reading)

Inlet Air Pressure Sensor (Service Code 12)

Inlet Air Pressure Sensor Circuit

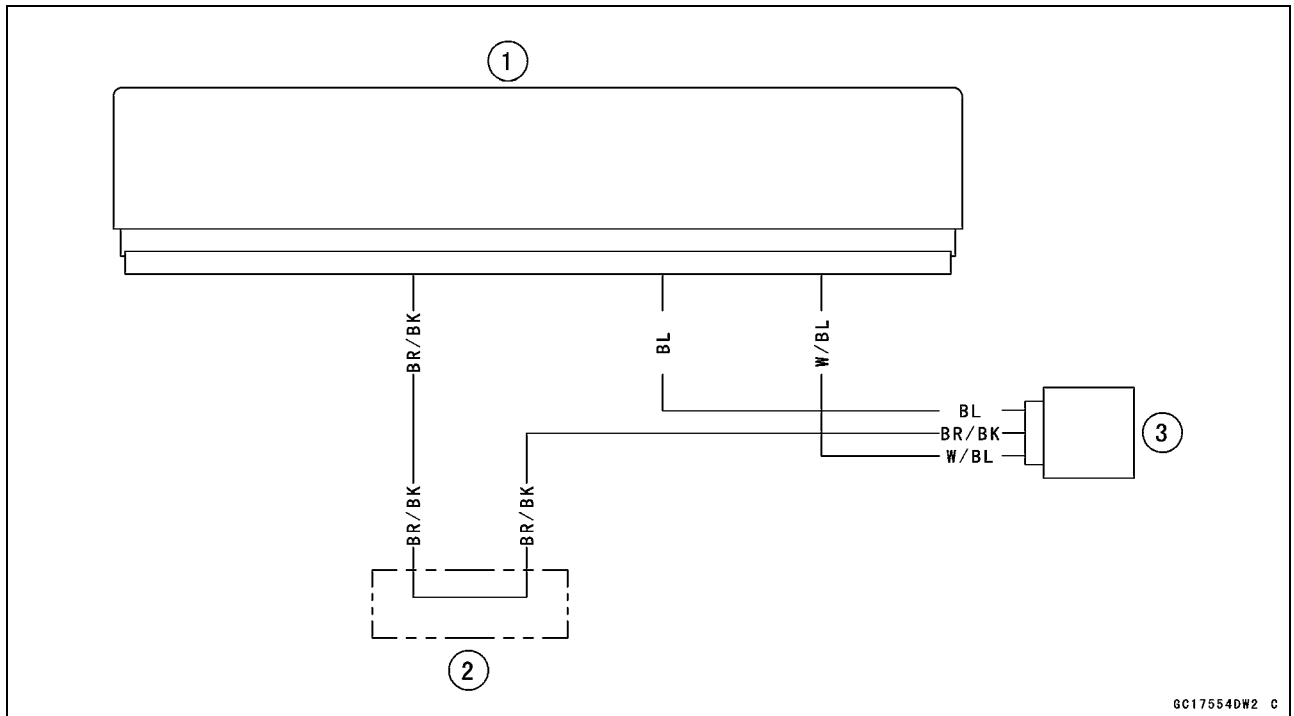

GC17554DW2 C

- 1. ECU
- 2. Water-proof Joint
- 3. Inlet Air Pressure Sensor

3-52 FUEL SYSTEM (DFI)

Inlet Air Temperature Sensor (Service Code 13)

Inlet Air Temperature Sensor Removal/Installation

NOTICE

Never drop the inlet air temperature sensor especially on a hard surface. Such a shock to the sensor can damage it.

- Remove the seat (see Seat Removal in the Frame chapter).
- Disconnect the connector [A] from the inlet air temperature sensor.
- Remove the screw [B].
- Pull out the inlet air temperature sensor.
- Put the inlet air temperature sensor into the air cleaner housing.
- Tighten:
Torque - Inlet Air Temperature Sensor Mounting Screw [A]:
1.2 N·m (0.12 kgf·m, 11 in·lb)
- Connect the sensor connector [B].

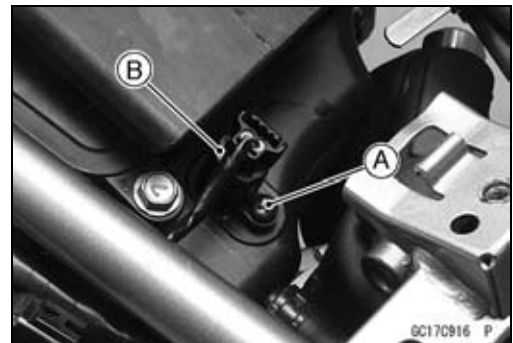
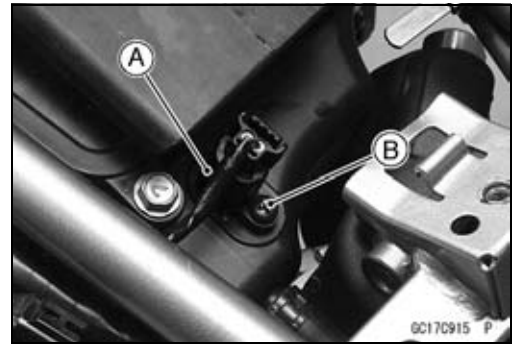

Inlet Air Temperature Sensor Output Voltage Inspection

NOTE

○Be sure the battery is fully charged.

- Turn the ignition switch OFF.
- Remove the seat (see Seat Removal in the Frame chapter).
- Disconnect the inlet air temperature sensor connector and connect the harness adapter [A] between these connectors as shown.

Main Harness [B]

Inlet Air Temperature Sensor [C]

Special Tool - Measuring Adapter: 57001-1700

- Connect a digital meter [D] to the harness adapter leads.

Inlet Air Temperature Sensor Output Voltage Connections to Adapter:

Digital Meter (+) → R (sensor P/BK) lead

Digital Meter (-) → BK (sensor BR/BK) lead

- Measure the output voltage with the engine stopped and the connector joined.
- Turn the ignition switch ON.

Output Voltage

Standard: About DC 2.25 ~ 2.50 V at inlet air temperature 20°C (68°F)

NOTE

○The output voltage changes according to the inlet air temperature.

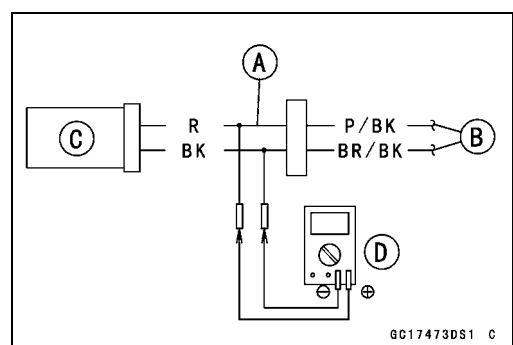
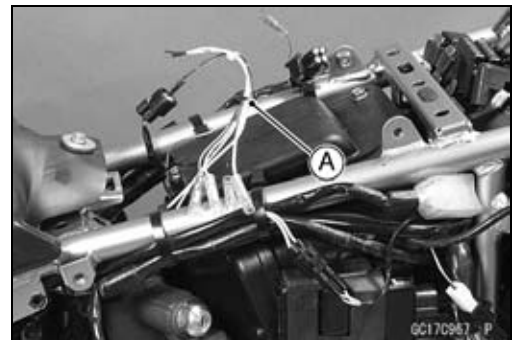

Inlet Air Temperature Sensor (Service Code 13)

- Turn the ignition switch OFF.
- ★ If the reading is within the standard, check the ECU for its ground and power supply (see ECU Power Supply Inspection).
- ★ If the ground and power supply are good, replace the ECU (see ECU Removal/Installation).
- ★ If the reading is out of the standard, remove the ECU and check the wiring for continuity between main harness connectors.
- Disconnect the ECU and sensor connectors.

Wiring Inspection

ECU Connector [A] ←→

Inlet Air Temperature Sensor Connector [B]

P/BK lead (ECU terminal 25) [C]

BR/BK lead (ECU terminal 24) [D]

- ★ If the wiring is good, check the inlet air temperature sensor resistance (see Inlet Air Temperature Sensor Resistance Inspection).

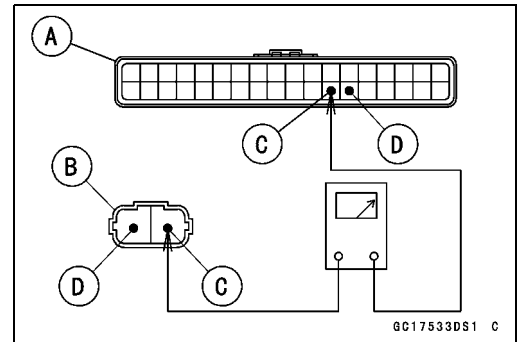

Inlet Air Temperature Sensor Resistance Inspection

- Remove the inlet air temperature sensor (see Inlet Air Temperature Sensor Removal/Installation).
- Suspend the sensor [A] in a container of machine oil so that the heat-sensitive portion is submerged.
- Suspend a thermometer [B] with the heat-sensitive portion [C] located in almost the same depth with the sensor.

NOTE

○ The sensor and thermometer must not touch the container side or bottom.

- Place the container over a source of heat and gradually raise the temperature of the oil while stirring the oil gently for even temperature.
- Using a digital meter, measure the internal resistance of the sensor across the terminals at the temperatures shown in the following.

Inlet Air Temperature Sensor Resistance

Standard: 5.4 ~ 6.6 kΩ at 0°C (32°F)

0.29 ~ 0.39 kΩ at 80°C (176°F)

- ★ If the reading is out of the standard, replace the sensor.
- ★ If the reading is within the standard, but the problem still exists, replace the ECU (see ECU Removal/Installation).

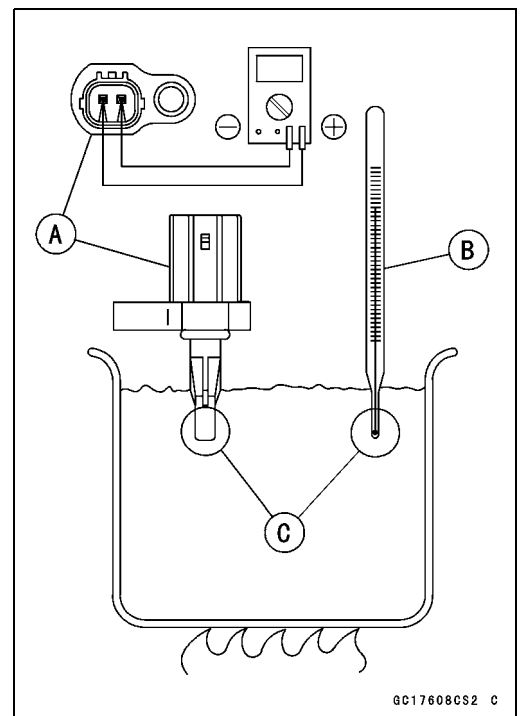

3-54 FUEL SYSTEM (DFI)

Inlet Air Temperature Sensor (Service Code 13)

Inlet Air Temperature Sensor Circuit

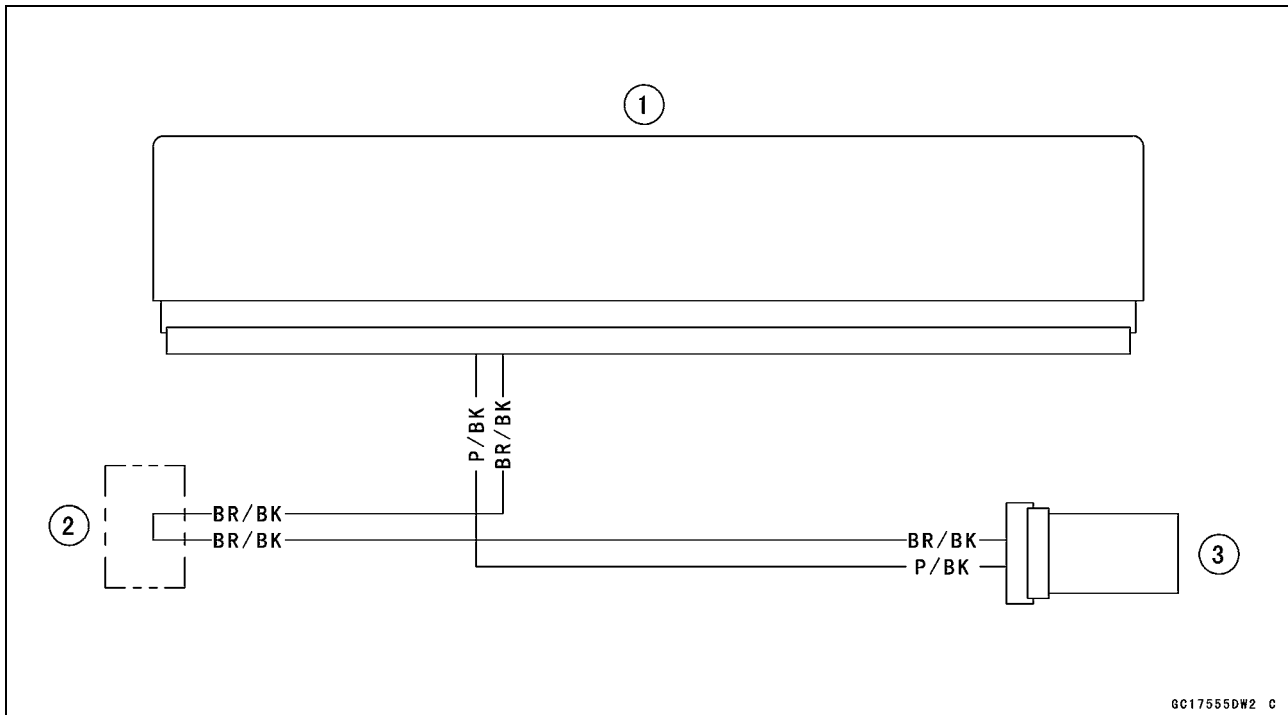

1. ECU
2. Water-proof Joint
3. Inlet Air Temperature Sensor

Water Temperature Sensor (Service Code 14)

Water Temperature Sensor Removal/Installation

NOTICE

Never drop the water temperature sensor especially on a hard surface. Such a shock to the sensor can damage it.

- Drain the coolant (see Coolant Change in the Periodic Maintenance chapter).
 - Remove:
 - Connector [A]
 - Water Temperature Sensor [B]
 - Replace the O-ring with a new one, and tighten the water temperature sensor.
- Torque - Water Temperature Sensor: 12 N·m (1.2 kgf·m, 106 in·lb)**
- Fill the engine with coolant and bleed the air from the cooling system (see Coolant Change in the Periodic Maintenance chapter).

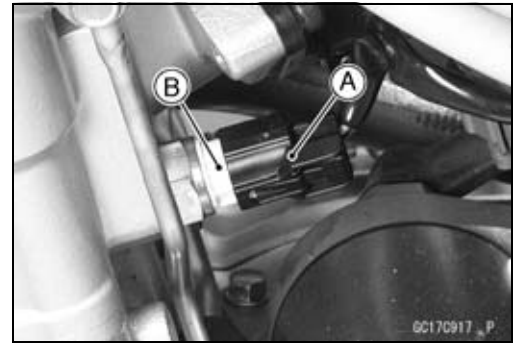

Water Temperature Sensor Output Voltage Inspection

NOTE

○Be sure the battery is fully charged.

- Turn the ignition switch OFF.
- Disconnect the water temperature sensor connector and connect the harness adapter [A] between these connectors as shown.
 - Main Harness [B]
 - Water Temperature Sensor [C]

Special Tool - Measuring Adapter: 57001-1700

- Connect a digital meter [D] to the harness adapter leads.

Water Temperature Sensor Output Voltage Connections to Adapter:

Digital Meter (+) → R (sensor GY) lead

Digital Meter (-) → BK (sensor BR/BK) lead

- Measure the output voltage with the engine stopped and with the connector joined.
- Turn the ignition switch ON.

Output Voltage

Standard: About DC 2.80 ~ 2.97 V at 20°C (68°F)

NOTE

○The output voltage changes according to the coolant temperature in the engine.

- Turn the ignition switch OFF.
- ★If the reading is within the standard, check the ECU for its ground and power supply (see ECU Power Supply Inspection).
- ★If the ground and power supply are good, replace the ECU (see ECU Removal/Installation).

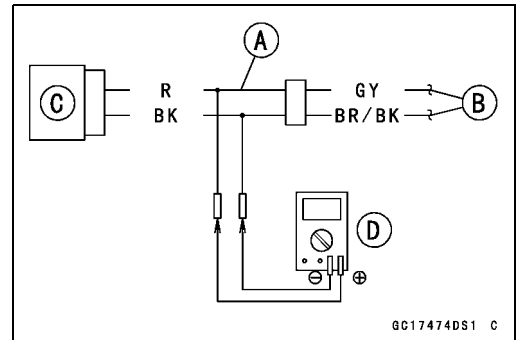

3-56 FUEL SYSTEM (DFI)

Water Temperature Sensor (Service Code 14)

★ If the reading is out of the standard, remove the ECU and check the wiring for continuity between main harness connectors.

○ Disconnect the ECU and sensor connectors.

Wiring Inspection

ECU Connector [A] ←→

Water Temperature Sensor Connector [B]

GY lead (ECU terminal 22) [C]

BR/BK lead (ECU terminal 24) [D]

★ If the wiring is good, check the water temperature sensor resistance (see Water Temperature Sensor Resistance Inspection).

Water Temperature Sensor Resistance Inspection

● Refer to the Water Temperature Sensor Inspection in the Electrical System chapter.

★ If the reading is within the standard, but the problem still exists, replace the ECU (see ECU Removal/Installation).

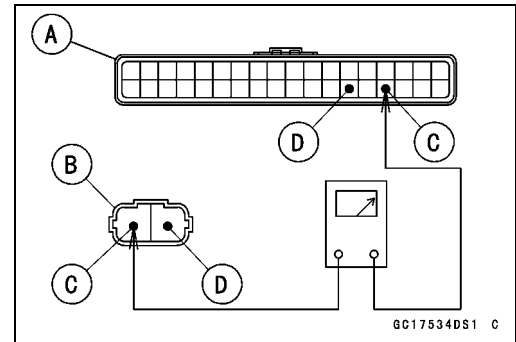

Water Temperature Sensor Circuit

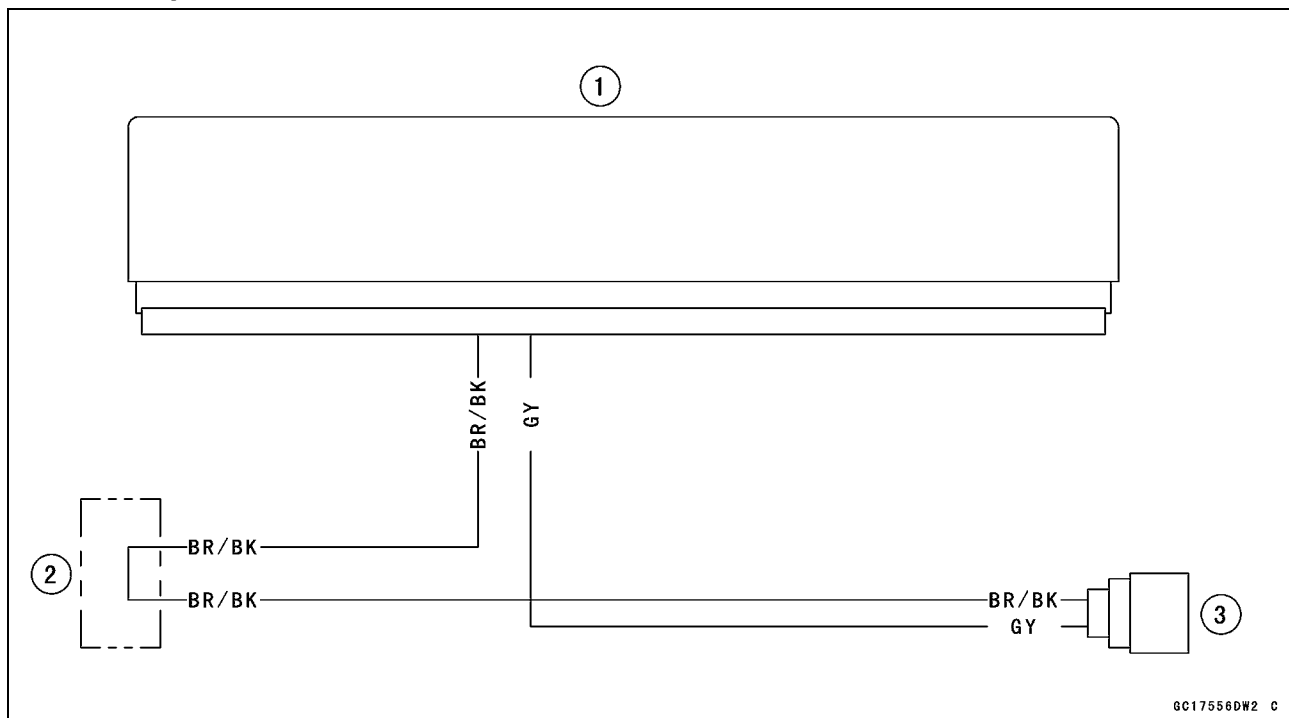

1. ECU

2. Water-proof Joint

3. Water Temperature Sensor

Crankshaft Sensor (Service Code 21)

The crankshaft sensor has no power source, and when the engine stops, the crankshaft sensor generates no signals.

Crankshaft Sensor Removal/Installation

- Refer to the Starter Coil Removal/Installation in the Electrical System chapter.

Crankshaft Sensor Resistance Inspection

- Refer to the Crankshaft Sensor Inspection in the Electrical System chapter.
- ★ If the reading is within the standard, check the peak voltage (see Crankshaft Sensor Peak Voltage Inspection).

Crankshaft Sensor Peak Voltage Inspection

- Refer to the Crankshaft Sensor Peak Voltage Inspection in the Electrical System chapter.
- ★ If the reading is within the standard, remove the ECU and check the wiring for continuity between main harness connectors.
- Disconnect the ECU and sensor connectors.

Wiring Inspection

ECU Connector [A] ↔

Crankshaft Sensor Connector [B]

G/W lead (ECU terminal 3) [C]

W/Y lead (ECU terminal 9) [D]

- ★ If the wiring is good, check the ECU for its ground and power supply (see ECU Power Supply Inspection).
- ★ If the ground and power supply are good, replace the ECU (see ECU Removal/Installation).

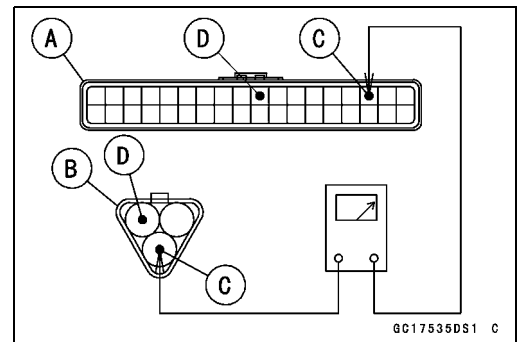

Crankshaft Sensor Circuit

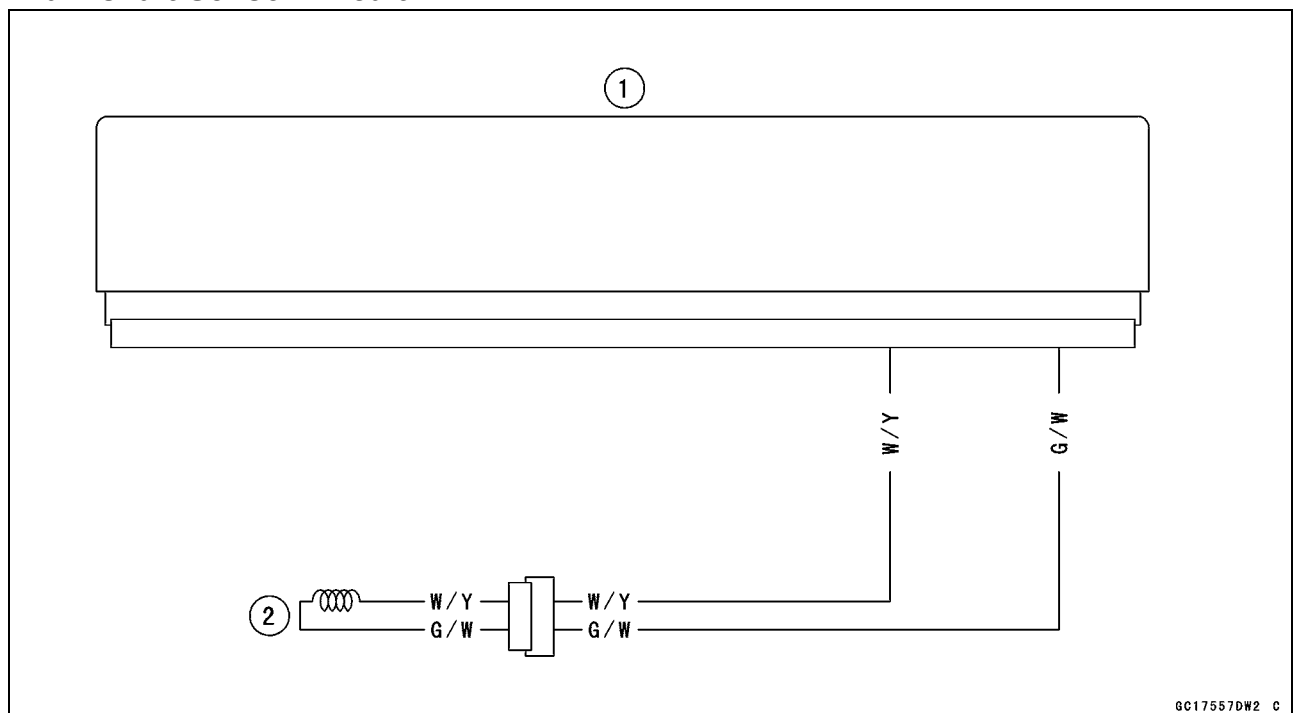

1. ECU
2. Crankshaft Sensor

3-58 FUEL SYSTEM (DFI)

Speed Sensor (Service Code 24)

Speed Sensor Removal/Installation

- Refer to the Speed Sensor Removal/Installation in the Electrical System chapter.

Speed Sensor Input Voltage Inspection

NOTE

○ Be sure the battery is fully charged.

- Turn the ignition switch OFF.
- Remove the head light body (see Head Light Body Removal in the Electrical System chapter).
- Disconnect the speed sensor connector [A].



- Connect the harness adapter [A] between these connectors.

Special Tool - Throttle Sensor Setting Adapter #1: 57001-1400

- Connect a digital meter to the harness adapter leads.

Speed Sensor Input Voltage

Connections to Adapter:

Digital Meter (+) → Y/W (sensor R) lead

Digital Meter (-) → BK/BL (sensor BK) lead

- Measure the input voltage with the engine stopped and with the connector joined.
- Turn the ignition switch ON.

Input Voltage

Standard: About DC 9 ~ 11 V

- Turn the ignition switch OFF.
- ★ If the reading is within the standard, check the output voltage (see Speed Sensor Output Voltage Inspection).
- ★ If the reading is out of the standard, check the speed sensor power supply voltage (see Meter Unit Inspection in the Electrical System chapter).

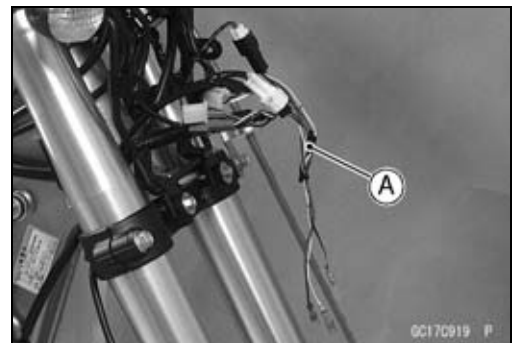

Speed Sensor (Service Code 24)

★If the speed sensor power supply voltage is within the standard, check the wiring for continuity between main harness connectors.

Wiring Inspection

Speed Meter Connector [A] ↔

Speed Sensor Connector [B]

R lead [C]

Battery Negative (-) Terminal [D] ↔

Speed Sensor Connector [E]

BK/Y lead [F]

★If the wiring is good, check the ECU for its ground and power supply (see ECU Power Supply Inspection).

★If the ground and power supply are good, replace the ECU (see ECU Removal/Installation).

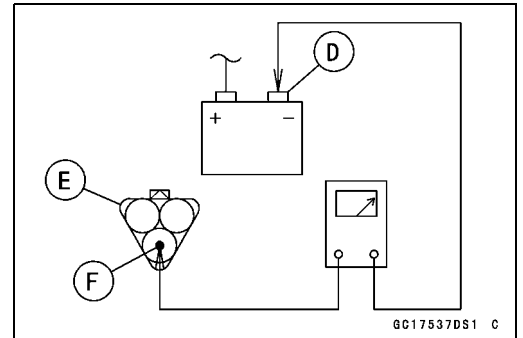
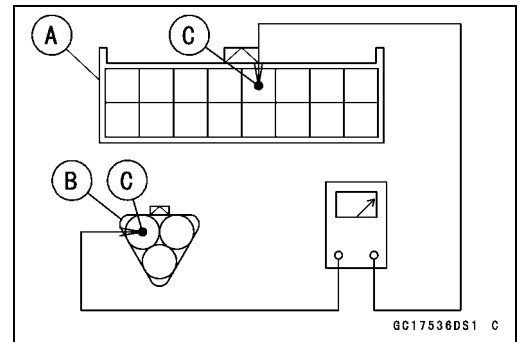

Speed Sensor Output Voltage Inspection

- Measure the output voltage at the speed sensor in the same way as input voltage inspection, note the following.
- Disconnect the speed sensor connector and connect the harness adapter [A] between these connectors.

Special Tool - Throttle Sensor Setting Adapter #1: 57001-1400

Speed Sensor Output Voltage

Connections to Adapter:

Digital Meter (+) → BL (sensor W) lead

Digital Meter (-) → BK/BL (sensor BK) lead

- Measure the output voltage with the engine stopped and with the connector joined.
- Turn the ignition switch ON.

Output Voltage

Standard: Less than DC 0.6 V or over than DC 4.8 V at ignition switch ON and 0 km/h

- Using the jack, raise the front wheel off the ground.

Special Tool - Jack: 57001-1238

NOTE

○ Rotate the front wheel by hand, confirm the output voltage will be raise or lower.

- Turn the ignition switch OFF.
- ★ If the reading is out of the standard, replace the sensor.

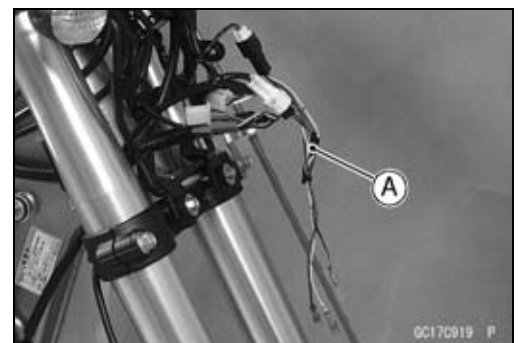

3-60 FUEL SYSTEM (DFI)

Speed Sensor (Service Code 24)

★ If the reading is within the standard, remove the ECU and check the wiring for continuity between main harness connectors.

○ Disconnect the ECU and sensor connectors.

Wiring Inspection

ECU Connector [A] ↔

Speed Sensor Connector [B]

G/R lead (ECU terminal 26) [C]

★ If the wiring is good, check the ECU for its ground and power supply (see ECU Power Supply Inspection).

★ If the ground and power supply are good, replace the ECU (see ECU Removal/Installation).

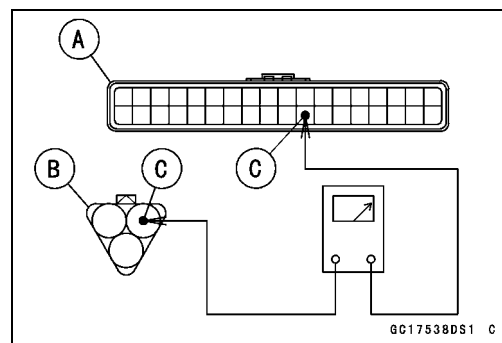

Speed Sensor Circuit

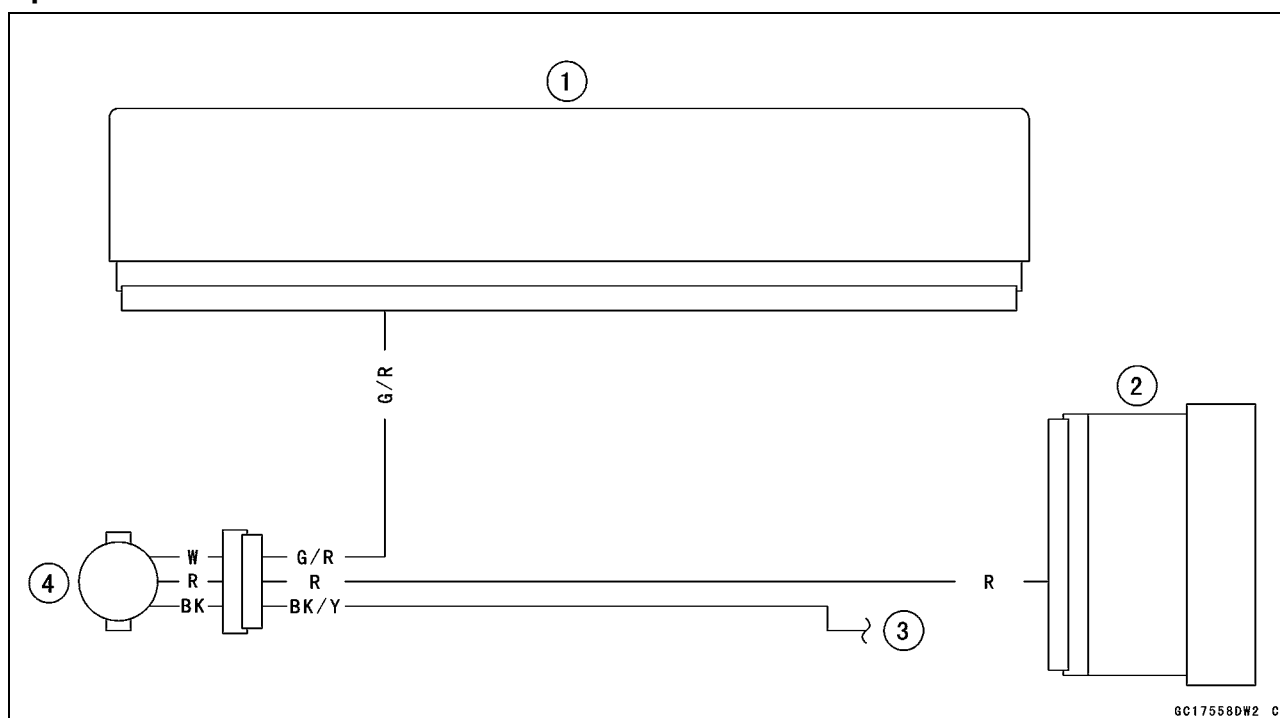

1. ECU
2. Meter Unit
3. Battery Negative (-) Terminal
4. Speed Sensor

Vehicle-down Sensor (Service Code 31)

This sensor has a weight [A] with two magnets inside, and sends a signal to the ECU. But when the motorcycle banks 60 ~ 70° or more to either side (in fact falls down), the weight turns and the signal changes. The ECU senses this change, and stops the fuel pump relay, the fuel injectors and the ignition system.

Hall IC [B]

When the motorcycle is down, the ignition switch is left ON. If the starter button is pushed, the electric starter turns but the engine does not start. To start the engine again, raise the motorcycle, turn the ignition switch OFF, and then ON.

- Vehicle-down Sensor [A]
- Ground Terminal BR/BK [B]
- Output Terminal Y/G [C]
- Power Source Terminal BL [D]

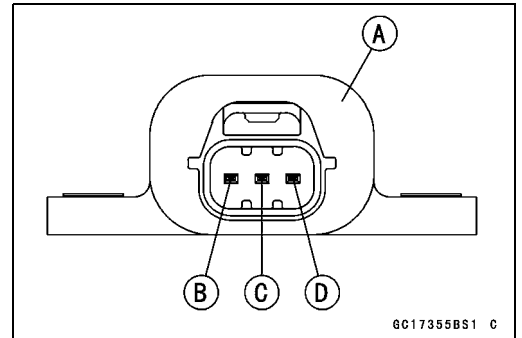
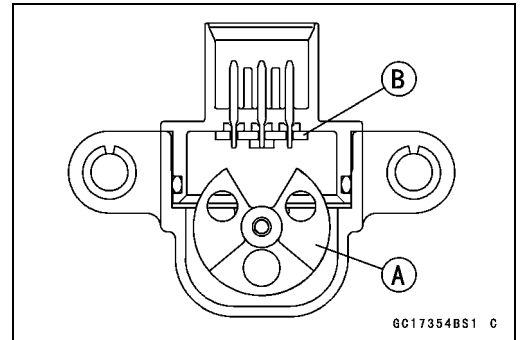

Vehicle-down Sensor Removal

NOTICE

Never drop the vehicle-down sensor especially on a hard surface. Such a shock to the sensor can damage it.

- Remove:
 - Side Cover (see Side Cover Removal in the Frame chapter)
 - Bolts [A]
 - Vehicle-down Sensor [B]

- Remove:
 - Connector [A]
 - Bolts [B]
 - Vehicle-down Sensor

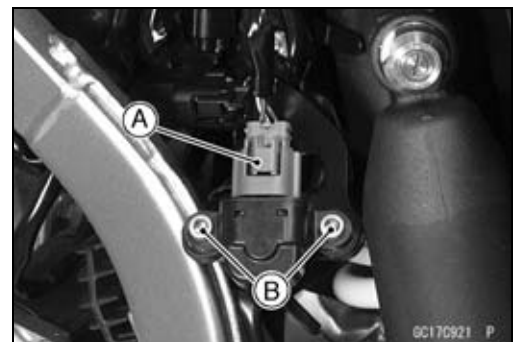

3-62 FUEL SYSTEM (DFI)

Vehicle-down Sensor (Service Code 31)

Vehicle-down Sensor Installation

- The UP mark [A] of the sensor should face upward.
- Tighten:
Torque - Vehicle-down Sensor Mounting Bolts: 6.9 N·m
(0.70 kgf·m, 61 in·lb)

⚠ WARNING

Incorrect installation of the vehicle-down sensor could cause sudden loss of engine power. The rider could lose balance during certain riding situations for an accident resulting in injury or death. Ensure that the vehicle-down sensor is held in place by the sensor brackets.

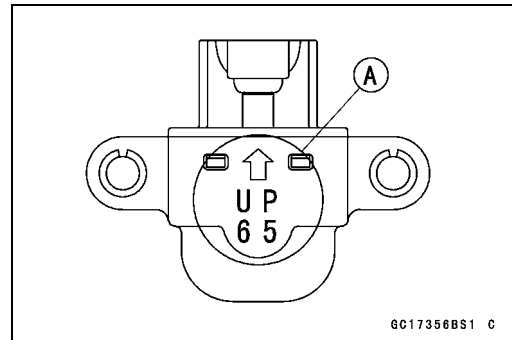

Vehicle-down Sensor Input Voltage Inspection

NOTE

○Be sure the battery is fully charged.

- Turn the ignition switch OFF.
- Disconnect the vehicle-down sensor connector and connect the harness adapter [A] between these connectors as shown.

Main Harness [B]

Vehicle-down Sensor [C]

Special Tool - Measuring Adapter: 57001-1700

- Connect a digital meter [D] to the harness adapter leads.

Vehicle-down Sensor Input Voltage

Connections to Adapter:

Digital Meter (+) → R (sensor BL) lead

Digital Meter (-) → BK (sensor BR/BK) lead

- Measure the input voltage with the engine stopped and with the connector joined.
- Turn the ignition switch ON.

Input Voltage

Standard: DC 4.75 ~ 5.25 V

- Turn the ignition switch OFF.
 - ★ If the reading is within the standard, check the output voltage (see Vehicle-down Sensor Output Voltage Inspection).
 - ★ If the reading is out of the standard, remove the ECU and check the wiring for continuity between main harness connectors.
- Disconnect the ECU and sensor connectors.

Wiring Inspection

ECU Connector [A] ↔

Vehicle-down Sensor Connector [B]

BL lead (ECU terminal 13) [C]

BR/BK lead (ECU terminal 24) [D]

- ★ If the wiring is good, check the ECU for its ground and power supply (see ECU Power Supply Inspection).
- ★ If the ground and power supply are good, replace the ECU (see ECU Removal/Installation).

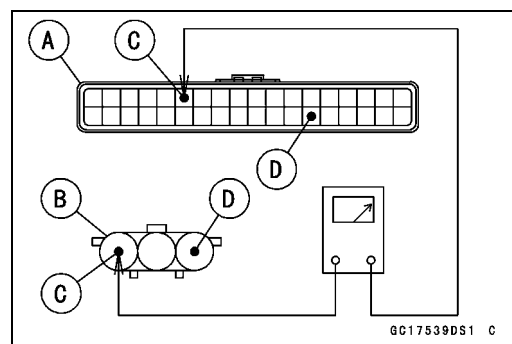
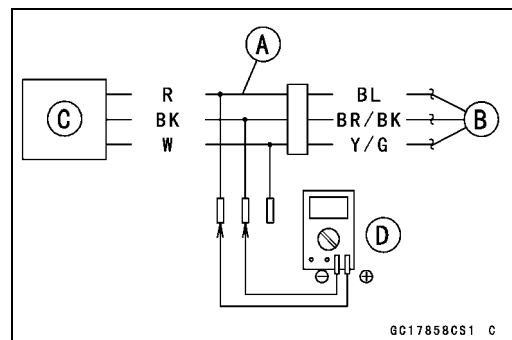
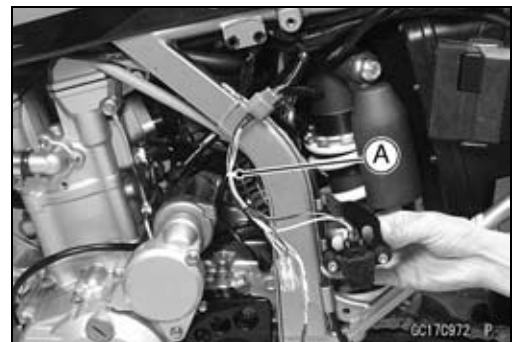

Vehicle-down Sensor (Service Code 31)

Vehicle-down Sensor Output Voltage Inspection

- Remove the vehicle-down sensor.
- Connect the harness adapter [A] to the vehicle-down sensor connectors as shown.

Special Tool - Measuring Adapter: 57001-1700

Main Harness [B]

Vehicle-down Sensor [C]

- Connect a digital meter [D] to the harness adapter leads.

Vehicle-down Sensor Output Voltage

Connections to Adapter:

Digital Meter (+) → W (sensor Y/G) lead

Digital Meter (-) → BK (sensor BR/BK) lead

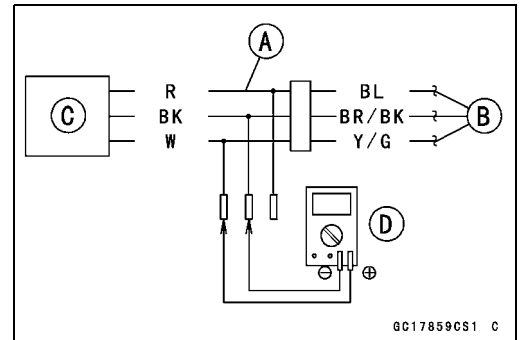

- Hold the sensor vertically.
- Measure the output voltage with the engine stopped and with the connector joined.
- Turn the ignition switch ON.
- Tilt the sensor 60 ~ 70° or more [A] right or left, then hold the sensor almost vertical with the arrow mark pointed up [B], and measure the output voltage.

Output Voltage

Standard: With sensor tilted 60 ~ 70° or more right or left: DC 0.65 ~ 1.35 V

With sensor arrow mark pointed up: DC 3.55 ~ 4.45 V

NOTE

○If you need to test again, turn the ignition switch OFF, and then ON.

- Turn the ignition switch OFF.
- ★If the reading is out of the standard, replace the sensor.

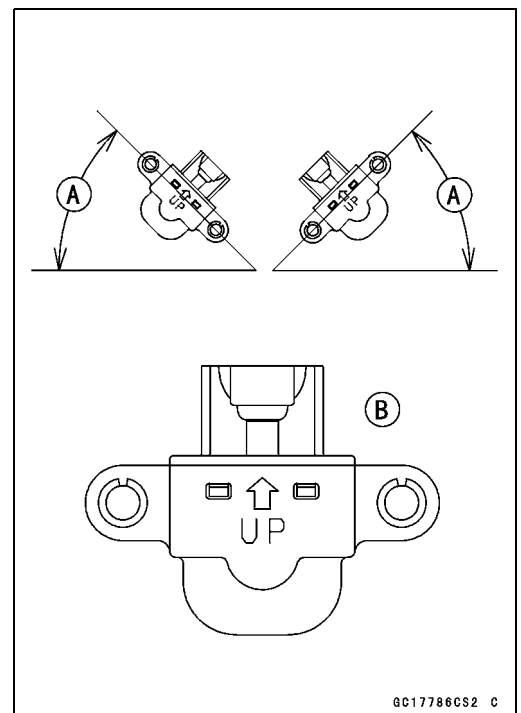

3-64 FUEL SYSTEM (DFI)

Vehicle-down Sensor (Service Code 31)

★ If the reading is within the standard, remove the ECU and check the wiring for continuity between main harness connectors.

○ Disconnect the ECU and sensor connectors.

Wiring Inspection

ECU Connector [A] ←→

Vehicle-down Sensor Connector [B]

Y/G lead (ECU terminal 2) [C]

BR/BK lead (ECU terminal 24) [D]

★ If the wiring is good, check the ECU for its ground and power supply (see ECU Power Supply Inspection).

★ If the ground and power supply are good, replace the ECU (see ECU Removal/Installation).

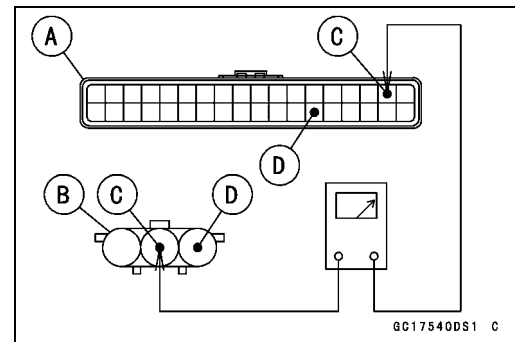

Vehicle-down Sensor Circuit

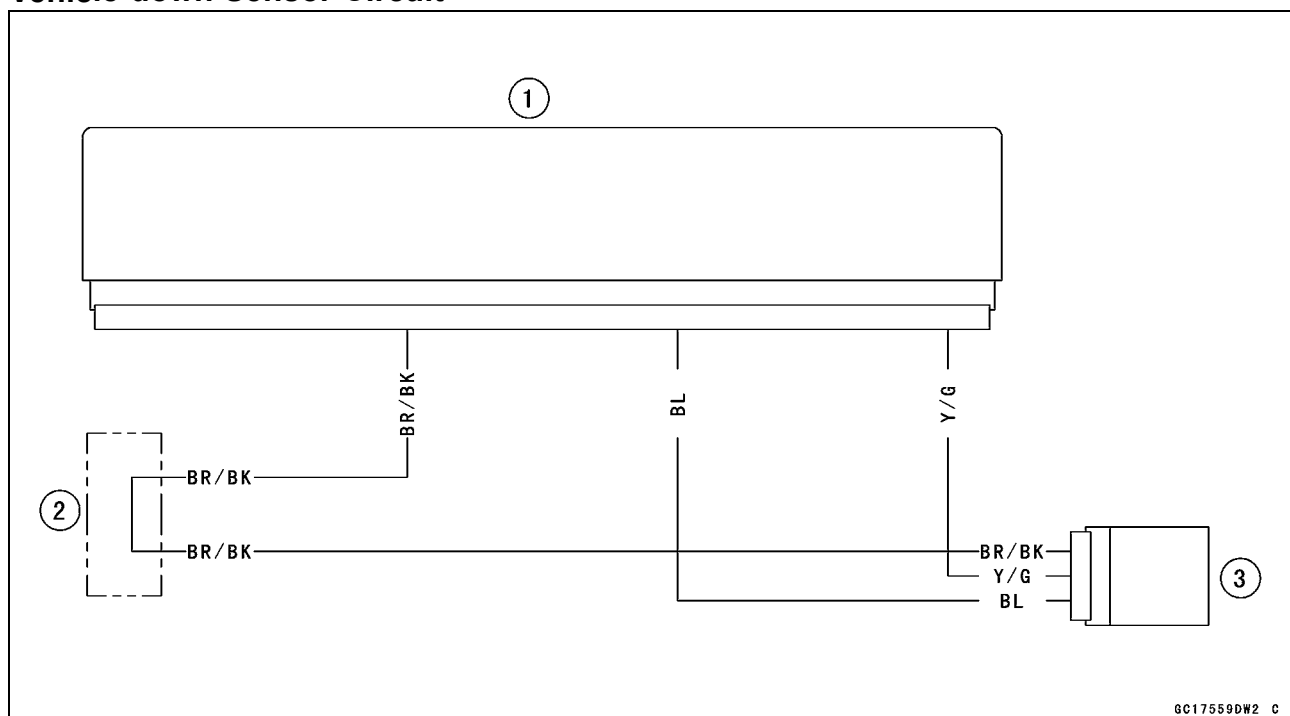

1. ECU
2. Water-proof Joint
3. Vehicle-down Sensor

Subthrottle Sensor (Service Code 32: TH and EUR Models/Service Code 62: IN Model)

The subthrottle sensor is a rotating variable resistor that change output voltage according to throttle operating. The ECU senses this voltage change and determines fuel injection quantity, and ignition timing according to engine rpm, and throttle opening.

- Input Terminal [A]
- Output Terminal [B]
- Ground Terminal [C]

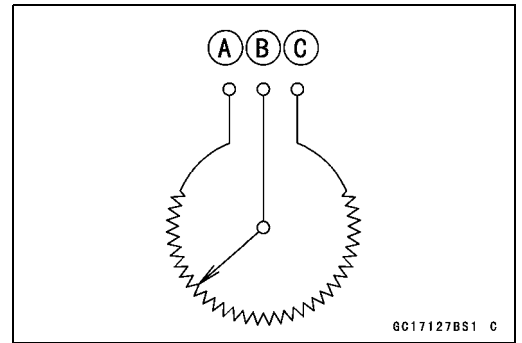

Subthrottle Sensor Removal/Adjustment

NOTICE

Do not remove or adjust the subthrottle sensor [A] since it has been adjusted and set with precision at the factory.
Never drop the throttle body assy especially on a hard surface. Such a shock to the subthrottle sensor can damage it.



Subthrottle Sensor Input Voltage Inspection

NOTE

○Be sure the battery is fully charged.

- Turn the ignition switch OFF.
- Disconnect the subthrottle sensor and connect the harness adapter [A] between these connectors.

Special Tool - Throttle Sensor Setting Adapter: 57001-1538

- Connect a digital meter to the harness adapter leads.

Subthrottle Sensor Input Voltage

Connections to Adapter:

- Digital Meter (+) → BK (sensor BL) lead**
- Digital Meter (-) → W (sensor BR/BK) lead**

- Measure the input voltage with the engine stopped and with the connector joined.
- Turn the ignition switch ON.

Input Voltage

Standard: DC 4.75 ~ 5.25 V

- Turn the ignition switch OFF.
- ★ If the reading is within the standard, check the output voltage (see Subthrottle Sensor Output Voltage Inspection).

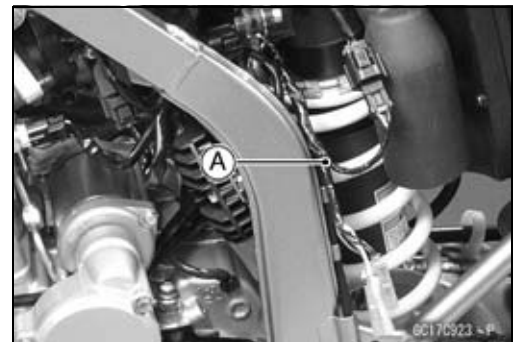

3-66 FUEL SYSTEM (DFI)

Subthrottle Sensor (Service Code 32: TH and EUR Models/Service Code 62: IN Model)

★ If the reading is out of the standard, remove the ECU and check the wiring for continuity between main harness connectors.

○ Disconnect the ECU and sensor connectors.

Wiring Inspection

ECU Connector [A] ←→

Subthrottle Sensor Connector [B]

BL lead (ECU terminal 13) [C]

BR/BK lead (ECU terminal 24) [D]

★ If the wiring is good, check the ECU for its ground and power supply (see ECU Power Supply Inspection).

★ If the ground and power supply are good, replace the ECU (see ECU Removal/Installation).

Subthrottle Sensor Output Voltage Inspection

● Measure the output voltage at the subthrottle sensor in the same way as input voltage inspection, note the following.

○ Disconnect the subthrottle sensor connector and connect the harness adapter [A] between these connectors.

Special Tool - Throttle Sensor Setting Adapter: 57001-1538

Subthrottle Sensor Output Voltage

Connections to Adapter:

Digital Meter (+) → R (sensor BR) lead

Digital Meter (-) → W (sensor BR/BK) lead

- Remove the fuel tank (see Fuel Tank Removal).
- Disconnect the subthrottle valve actuator harness connector [A].

KLX250S Model

- Remove:
 - Bolts [A]
 - Throttle Pulley Cover [B]

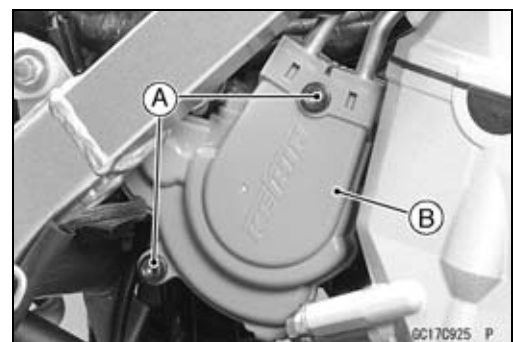
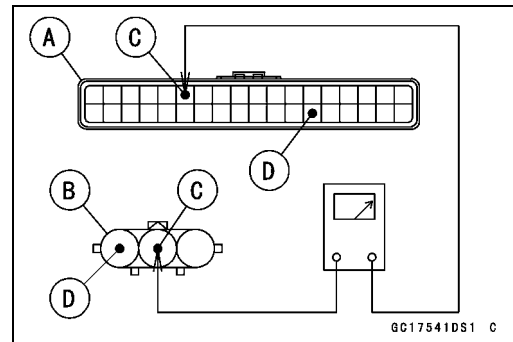

Subthrottle Sensor (Service Code 32: TH and EUR Models/Service Code 62: IN Model)

- Measure the output voltage with the engine stopped with the connector joined.
- Turn the ignition switch ON.
- Measure the output voltage when the subthrottle valve is completely closed by turning the lever [A] fully clockwise with a suitable tool.

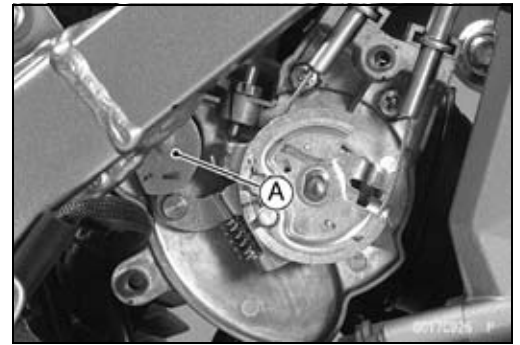

Output Voltage

Standard: DC 0.48 ~ 0.52 V at subthrottle valve full close position

DC 3.8 ~ 4.0 V at subthrottle valve full open position (for reference)

NOTE

- Turn the lever counterclockwise, confirm the output voltage will be raise.
- The standard voltage refers to the value when the voltage reading at the Input Voltage Inspection shows 5 V exactly.
- When the input voltage reading shows other than 5 V, derive a voltage range as follows.

Example:

In the case of a input voltage of 4.75 V.

$$0.48 \times 4.75 \div 5.00 = 0.46 \text{ V}$$

$$0.52 \times 4.75 \div 5.00 = 0.49 \text{ V}$$

Thus, the valid range is 0.46 ~ 0.49 V

- Turn the ignition switch OFF.
- ★ If the reading is out of the standard, check the subthrottle sensor resistance (see Subthrottle Sensor Resistance Inspection).
- ★ If the reading is within the standard, remove the ECU and check the wiring for continuity between main harness connectors.
- Disconnect the ECU and sensor connectors.

Wiring Inspection

ECU Connector [A] ←→

Subthrottle Sensor Connector [B]

BR/R lead (ECU terminal 27) [C]

BR/BK lead (ECU terminal 24) [D]

- ★ If the wiring is good, check the ECU for its ground and power supply (see ECU Power Supply Inspection).
- ★ If the ground and power supply are good, replace the ECU (see ECU Removal/Installation).

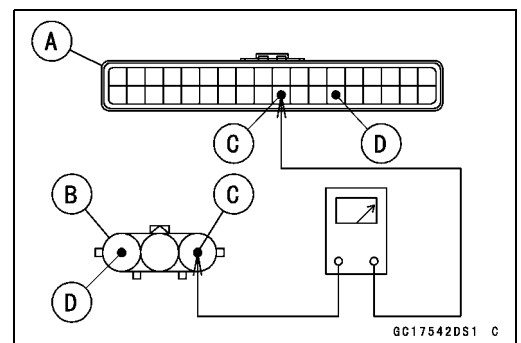

3-68 FUEL SYSTEM (DFI)

Subthrottle Sensor (Service Code 32: TH and EUR Models/Service Code 62: IN Model)

Subthrottle Sensor Resistance Inspection

- Disconnect the subthrottle sensor connector.
- Connect a harness adapter [A] to the subthrottle sensor.
- Measure the subthrottle sensor resistance.

Special Tool - Throttle Sensor Setting Adapter: 57001-1538

Subthrottle Sensor Resistance

Connections to Adapter:

Digital Meter (+) → BK (sensor BL) lead

Digital Meter (-) → W (sensor BR/BK) lead

Standard: 4 ~ 6 kΩ

- ★ If the reading is out of the standard, replace the throttle body assy.
- ★ If the reading is within the standard, but the problem still exists, replace the ECU (see ECU Removal/Installation).

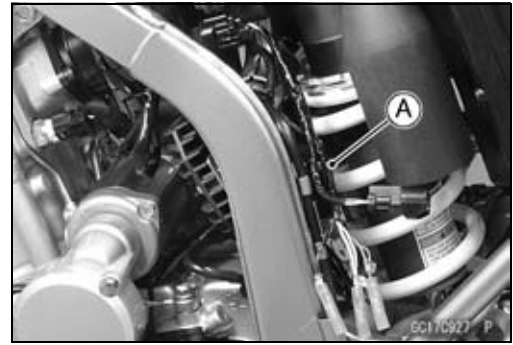

Subthrottle Sensor Circuit

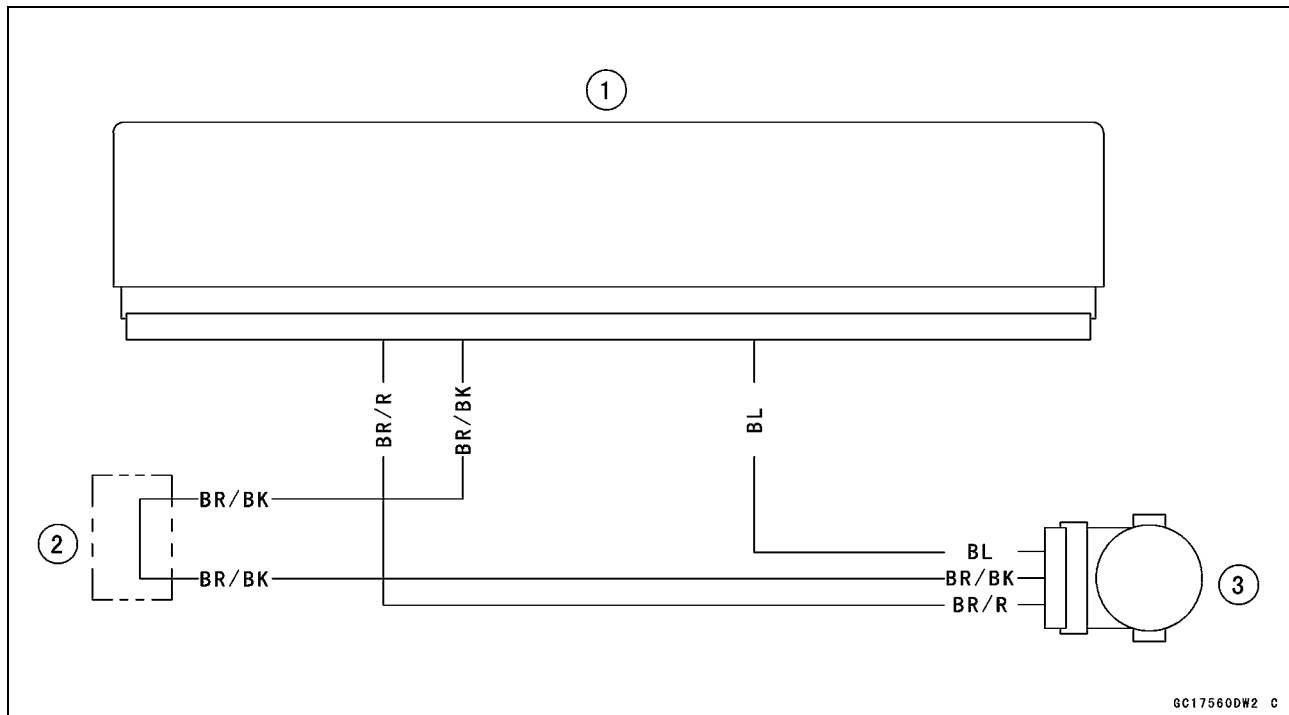

1. ECU
2. Water-proof Joint
3. Subthrottle Sensor

Oxygen Sensor - not activated (Service Code 33)

Oxygen Sensor Removal/Installation

- Refer to the Oxygen Sensor Removal/Installation in the Electrical System chapter.

Oxygen Sensor Inspection

- Warm up the engine thoroughly until the radiator fan starts.
- Turn the ignition switch OFF.
- Remove:
 - Seat (see Seat Removal in the Frame chapter)
- Pull the oxygen sensor lead connector [A] from the rear fender front bracket downward.

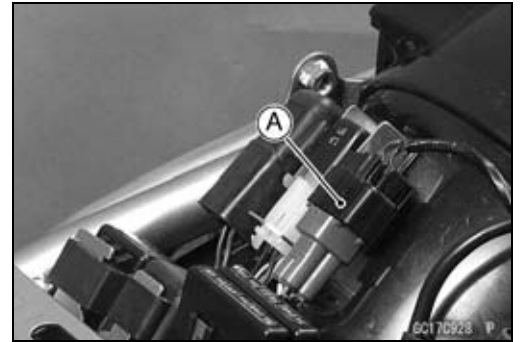

- Disconnect the oxygen sensor lead connector and connect the harness adapter [A] between these connectors.
 - Main Harness [B]
 - Oxygen Sensor [C]

Special Tool - Measuring Adapter: 57001-1700

- Connect a digital meter [D] to the harness adapter leads.

Oxygen Sensor Output Voltage

Connections to Adapter:

Digital Meter (+) → R (sensor BK) lead

Digital Meter (-) → BK (sensor GY) lead

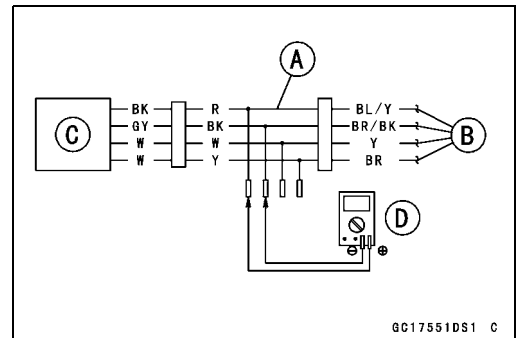
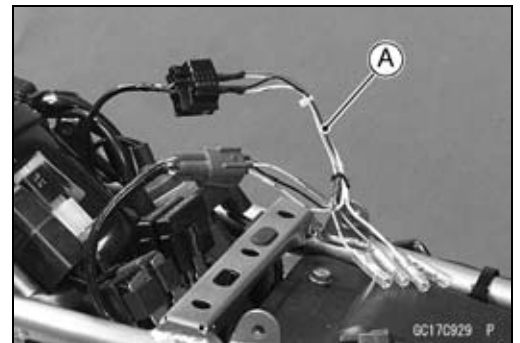

- Disconnect the hose [A] from the air suction valve cover.
- Disconnect the hose [B] from the air switching valve.

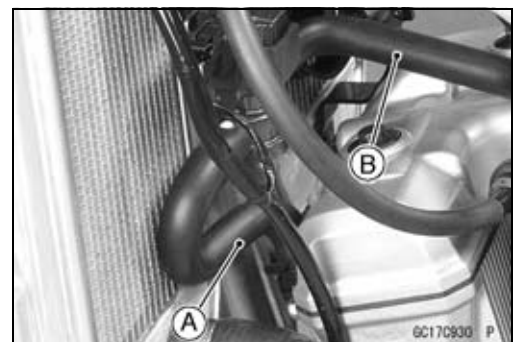

3-70 FUEL SYSTEM (DFI)

Oxygen Sensor - not activated (Service Code 33)

- Pull the air switching valve [A] from frame bracket.
- Do not disconnect the air switching valve connector [B].
- Install the suitable plug [C] on the fitting of the air suction valve cover, and shut off the secondary air.

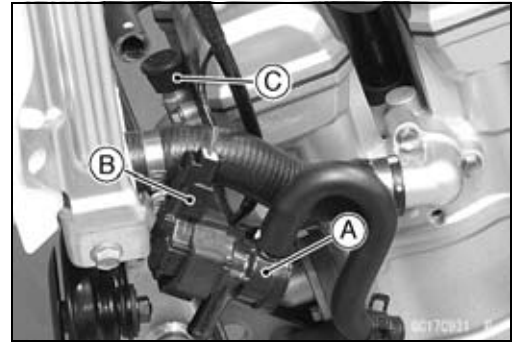

- Start the engine, and let it idle.
- Measure the output voltage with the connector joined.

Output Voltage (with Plug)

Standard: DC 0.8 V or more

- Next, remove the plug from the fitting [A] with idling.
- Measure the output voltage with the connector joined.

Output Voltage (without Plug)

Standard: DC 0.24 V or less

- Turn the ignition switch OFF



- ★ If the reading is out of the standard (with plugs: DC 0.7 V or more, without plugs: DC 0.2 V or less), remove the ECU and check the wiring for continuity between main harness connectors.
- Disconnect the ECU and sensor connectors.

Wiring Inspection

ECU Connectors [A] ←→

Oxygen Sensor Connector [B]

BL/Y lead (ECU terminal 7) [C]

BR/BK lead (ECU terminal 24) [D]

- ★ If the wiring is good, replace the sensor.
- ★ If the reading is within the standard (with plugs: DC 0.8 V or more, without plugs: DC 0.24 V or less), check the ECU for its ground and power supply (see ECU Power Supply Inspection).
- ★ If the ground and power supply are good, replace the ECU (see ECU Removal/Installation).

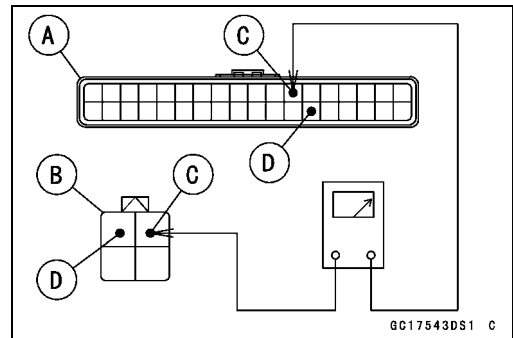

Oxygen Sensor - not activated (Service Code 33)

Oxygen Sensor Circuit

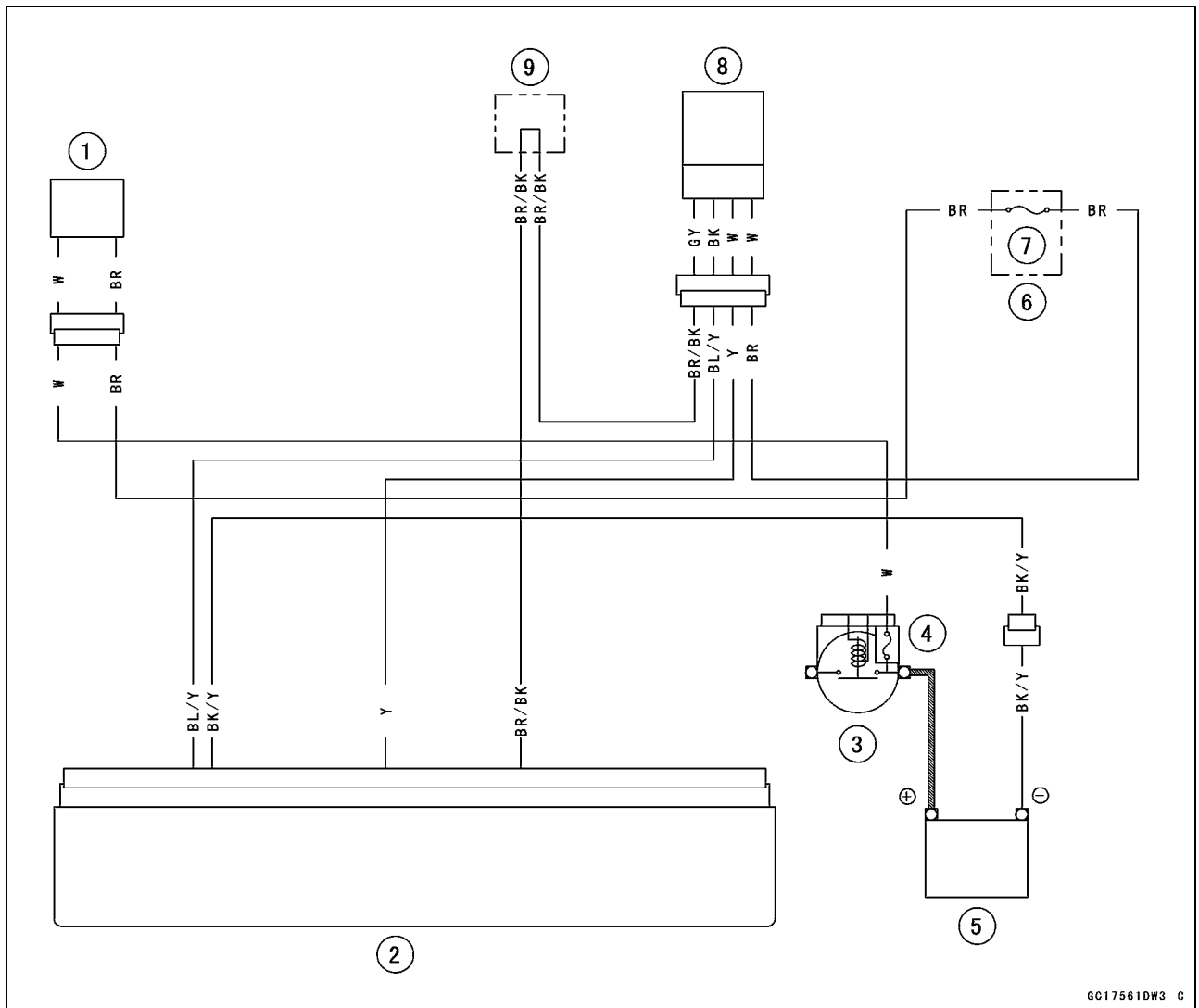

GC17561DW3 C

1. Ignition Switch
2. ECU
3. Starter Relay
4. Main Fuse 20 A
5. Battery 12 V 6 Ah
6. Fuse Box
7. Ignition Fuse 10 A
8. Oxygen Sensor
9. Water-proof Joint

3-72 FUEL SYSTEM (DFI)

Fuel Injector (Service Code 41)

Fuel Injector Removal

- Remove the fuel tank (see Fuel Tank Removal).
- Be sure to place a piece of cloth [A] around the fuel hose joint.
- Insert the screw driver [B] to the joint lock slit [C].
- Turn the driver to disconnect the joint lock [D].

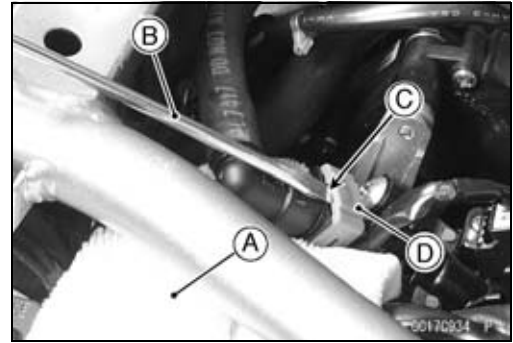

- Pull the fuel hose joint [A] out of the delivery pipe [B].



- Disconnect the injector connector [A].
- Remove the delivery pipe mounting screw [B].
- Remove the delivery pipe [C] together with the injector.

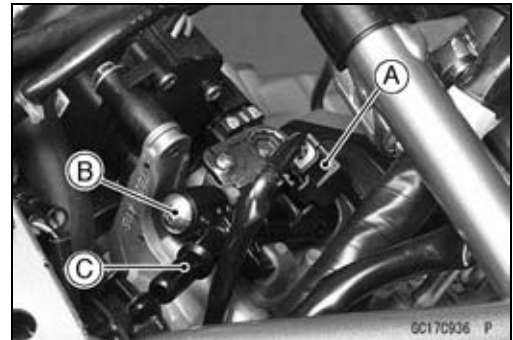

- Separate the injector [A] from the delivery pipe [B].

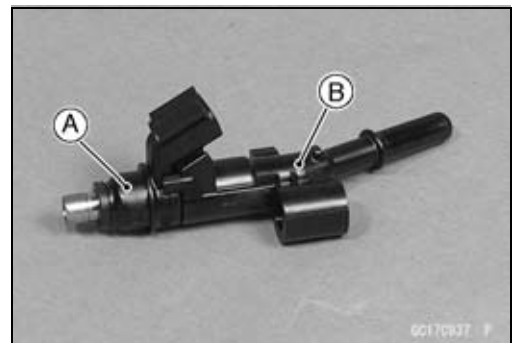

Fuel Injector Installation

- Replace the O-ring [A] and dust seal [B] with a new one.

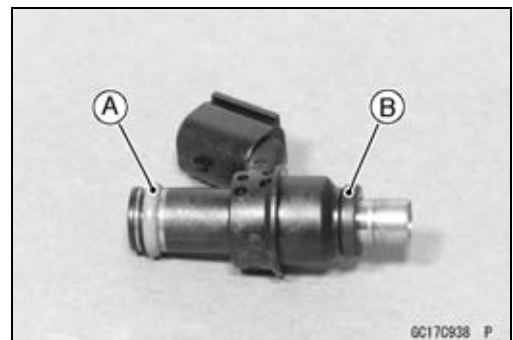

Fuel Injector (Service Code 41)

- Fit the fuel injector [B] between the projections [A] on the delivery pipe.

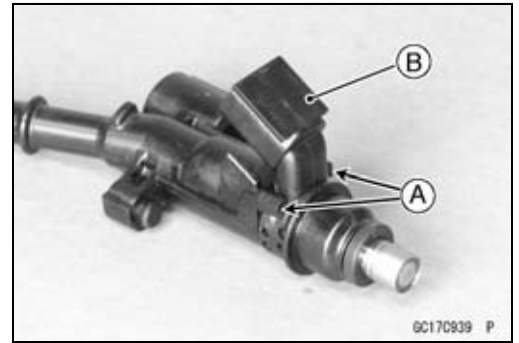

- Fit the projection [A] on the delivery pipe to the hollow [B] of the throttle body assy.

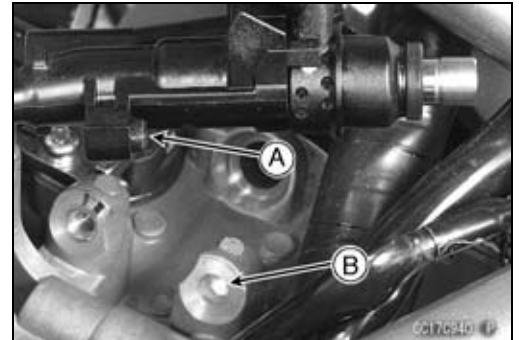

- Tighten the delivery pipe mounting screws [A]
- Connect the fuel injector connector [B].



- Insert the fuel hose joint [A] straight into the delivery pipe.
- Push the joint lock [B].
- Push and pull [C] the fuel hose joint back and forth more than two times and make sure it is locked and does not come off.

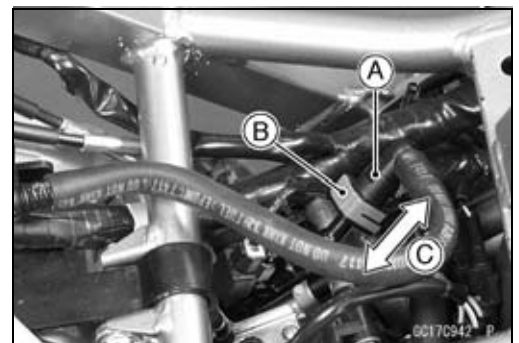

⚠ WARNING

Gasoline is extremely flammable and can be explosive under certain conditions. To prevent a fuel leak that could ignite or explode, check to be sure that the fuel hose joint is correctly and securely installed by sliding it back and forth several times. If installed correctly, the joint should not separate from the injector delivery pipe.

- ★ If it comes off, reinstall the hose joint.

3-74 FUEL SYSTEM (DFI)

Fuel Injector (Service Code 41)

Fuel Injector Audible Inspection

NOTE

○Be sure the battery is fully charged.

- Remove:
 - Fuel Tank (see Fuel Tank Removal)
 - Fuel Outlet Hose (see Fuel Injector Removal)
- Connect the following parts.
 - Fuel Pump Lead Connector
 - Fuel Hose [A]

Special Tool - Fuel Hose: 57001-1607

- Start the engine, and let it idle.
- Apply the tip of a screwdriver [B] to the fuel injector. Put the grip end into your ear, and listen whether the fuel injector is clicking or not.
- A sound scope can also be used.
- The click interval becomes shorter as the engine speed rises.
- ★If the injector click at a regular intervals, the injector is normal
- Turn the ignition switch OFF.
- ★If fuel injector dose not click, check the fuel injector resistance (see Fuel Injector Resistance Inspection)

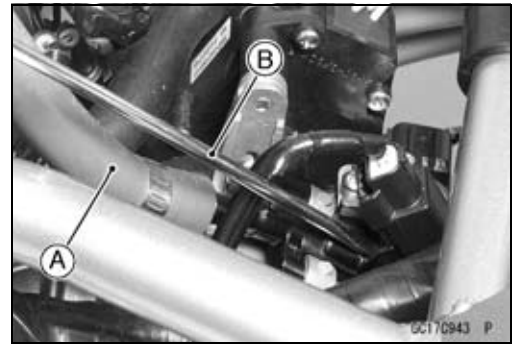

Fuel Injector Resistance Inspection

- Remove:
 - Fuel Tank (see Fuel Tank Remove)
 - Fuel Outlet Hose (see Fuel Injector Removal)
- Disconnect the injector connector.
- Connect a digital meter [A] to the injector terminal.
- Measure the fuel injector resistance.

Fuel Injector Resistance

Connections: BR/W terminal ↔ O/W terminal

Standard: 9.97 ~ 11.03 Ω @20°C (68 °F)

- ★If the reading is out of the standard, replace the injector.
- ★If the reading is within the standard, check the power supply voltage (see Fuel Injector Power Supply Voltage Inspection)

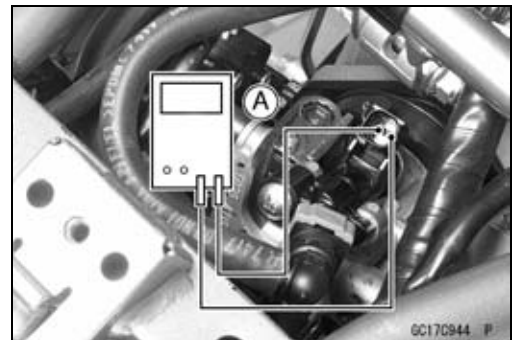

Fuel Injector (Service Code 41)

Fuel Injector Power Supply Voltage Inspection

NOTE

○Be sure the battery is fully charged.

- Turn the ignition switch OFF.
- Disconnect the injector connector and connect the measuring adapter [A] between these connector.
Main Harness [B]
Fuel Injector [C]

Special Tool - Measuring Adapter: 57001-1700

- Connect a digital meter [D] to the measure adapter lead.

Fuel Injector Power Supply Voltage

Connect the Adapter:

Digital Meter (+) → R (Injector BR/W) lead

Digital Meter (-) → Battery (-) Terminal

- Measure the power supply voltage with the engine stopped.
- Turn the engine stop switch to running position.
- Turn the ignition switch ON.

Power Supply Voltage

Standard: Battery Voltage

- Turn the ignition switch OFF.
- ★ If the voltage is out of the standard, check the power supply wiring (see Fuel Injector Circuit).
- ★ If the reading is within the standard, check the output voltage (see Fuel Injector Power Supply Voltage Inspection).

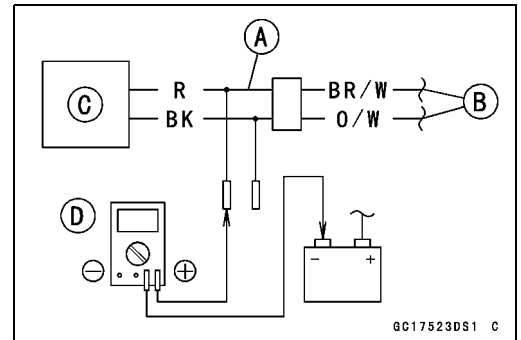
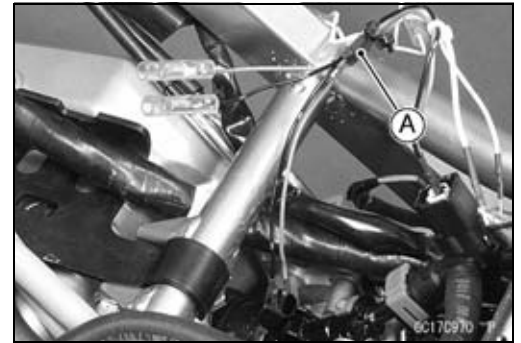

Fuel Injector Output Voltage Inspection

NOTE

○Be sure the battery is fully charged.

- Turn the ignition switch OFF.
- Remove the ECU (see ECU Remove).
- Do not disconnect the ECU connector.
- Using the needle adapter set and connect a digital meter [A] to the connector [B].

Special Tool - Needle Adapter Set: 57001-1457

Fuel Injector Output Voltage

Connect the ECU Connector:

Digital Meter (+) → O/W lead (ECU Terminal 16)

Digital Meter (-) → Battery (-) Terminal

- Measure the power supply voltage with the engine stopped with the connector jointed.
- Turn the engine stop switch to running position.
- Turn the ignition switch ON.

Output Voltage

Standard: Battery Voltage

- Turn the ignition switch OFF.
- ★ If the reading is within the standard, check the ECU for its ground and power supply (see ECU Power Supply Inspection)
- ★ If the ground and power supply are good, replace the ECU (see ECU Removal/Installation).

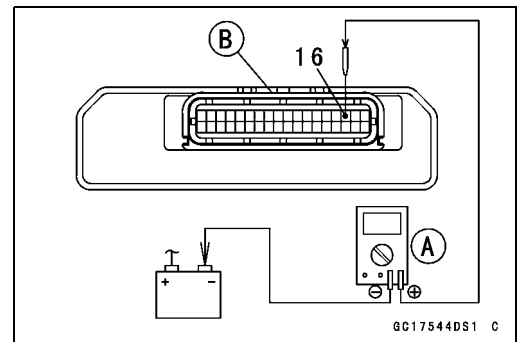

3-76 FUEL SYSTEM (DFI)

Fuel Injector (Service Code 41)

★ If the reading is out of the standard, remove the ECU and check the wiring for continuity between main harness connectors.

○ Disconnect the ECU and injector connectors.

Wiring Inspection

ECU Connector [A] ← → Fuel Injector connector [B]

O/W lead (ECU terminal 16) [C]

★ If the wiring good, check the ECU ground and power supply (see ECU Power Supply Inspection).

★ If the ground and power supply good, replace the ECU (see ECU Removal/Installation).

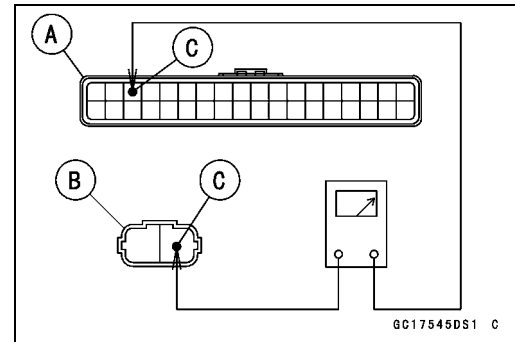

Injector Fuel Line Inspection

● Remove:

Fuel Tank (see Fuel Tank Removal)

Fuel Outlet Hose (see Fuel Injector Removal)

○ Be sure to place a piece of cloth around the fuel outlet pipe of fuel pump and delivery pipe of throttle body assy.

● Check the injector fuel line for leakage as follows:

○ Connect a commercially available vacuum/pressure pump [A] to the nipple of the delivery pipe [B] with the fuel hose [C] (both ends with the clamps [D]) as shown in the figure.

Upside View [E]

● Apply a soap and water solution to the areas [F] as shown.

● Watching the pressure gauge, squeeze the pump lever [G], and build up the pressure until the pressure reaches the maximum pressure.

Fuel Line Maximum Pressure

Standard: 300 kPa (3.06 kgf/cm², 44 psi)

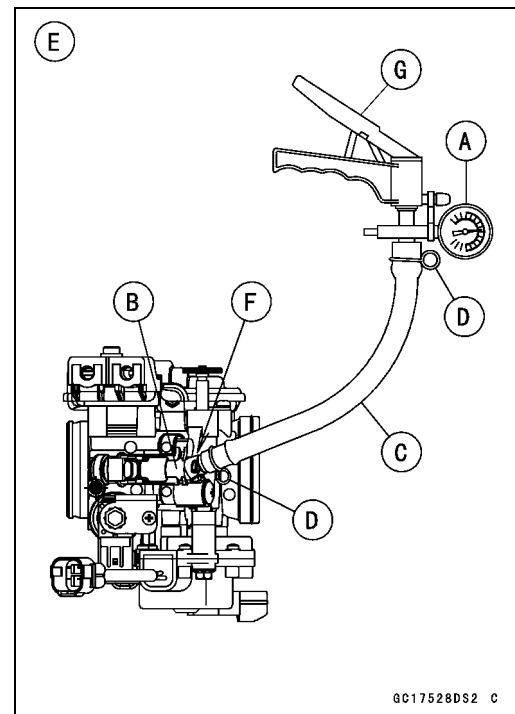

NOTICE

During pressure testing, do not exceed the maximum pressure for which the system is designed.

○ Watch the gauge for at least 6 seconds.

★ If the pressure holds steady, the fuel line is good.

★ If the pressure drops at once, or if bubbles are found in the area, the fuel line is leaking. Replace the delivery pipe assy, injector and related parts.

○ Repeat the leak test, and check the fuel line for no leakage.

● Install:

Fuel Outlet Hose (see Fuel Injector Installation)

Fuel Tank (see Fuel Tank Installation)

● Start the engine, check the fuel leakage.

Fuel Injector (Service Code 41)

Fuel Injector Circuit

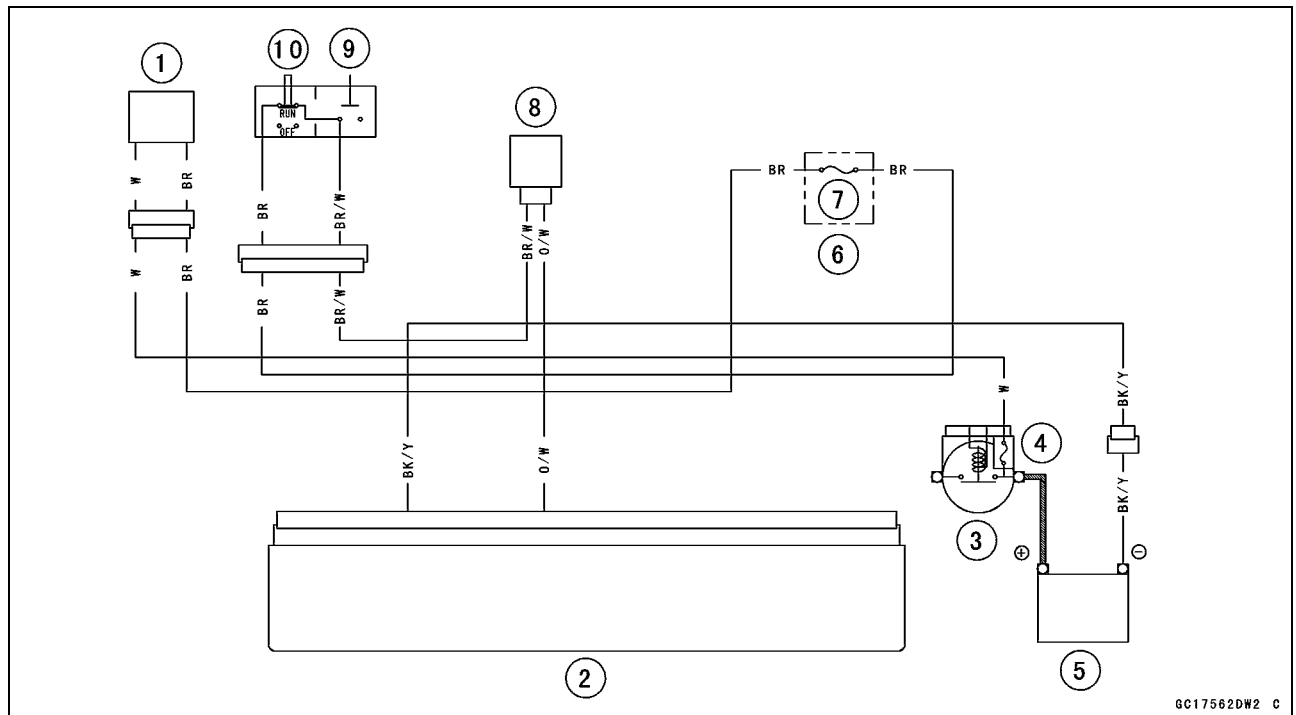

GC17562DW2 C

1. Ignition Switch
2. ECU
3. Starter Relay
4. Main Fuse 20 A
5. Battery 12 V 6 Ah
6. Fuse Box
7. Ignition Fuse 10 A
8. Fuel Injector
9. Starter Button
10. Engine Stop Switch

3-78 FUEL SYSTEM (DFI)

Fuel Pump Relay (Service Code 46)

Fuel Pump Relay Removal

NOTICE

Never drop the fuel pump relay especially on a hard surface. Such a shock to the relay can damage it.

- Remove the right radiator shroud (see Radiator Shroud Removal in the Frame chapter).
- Remove the fuel pump relay [A] and disconnect the connector.

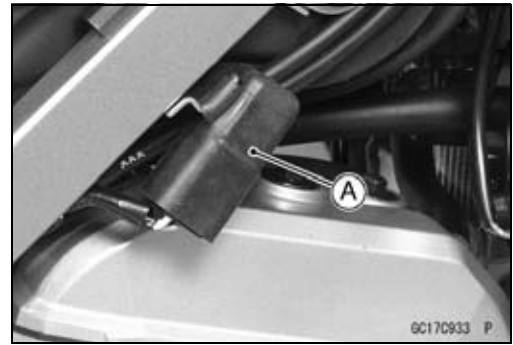

Fuel Pump Relay Inspection

- Remove the fuel pump relay (see Fuel Pump Relay Removal).
- Connect the hand tester [A] and one 12 V battery [B] to the relay connector [C] as shown in the figure.

Special Tool - Hand Tester: 57001-1394

Relay Coil Terminals [1] and [2]

Relay Switch Terminals [3] and [4]

Testing Relay

Tester range: 1 Ω range

Criteria: When battery is connected $\rightarrow 0 \Omega$

When battery is disconnected $\rightarrow \infty \Omega$

- ★ If the tester does not read as specified, replace the fuel pump relay.

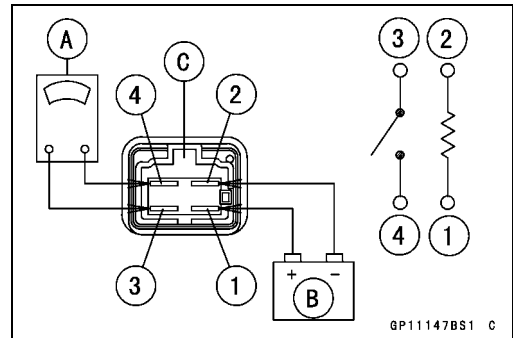

Fuel Pump Relay (Service Code 46)

Fuel Pump Relay Circuit

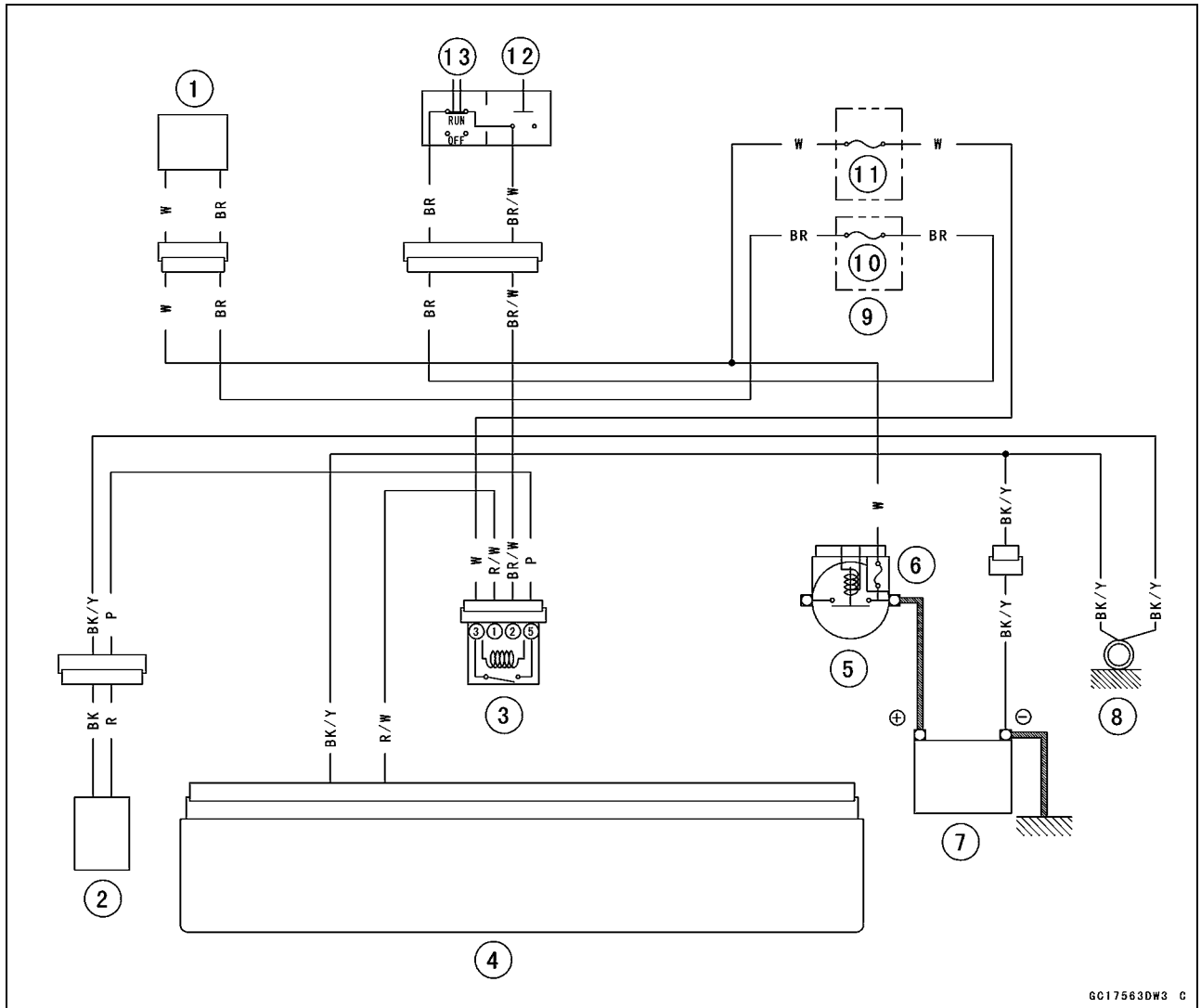

GC17563DW3 C

- 1. Ignition Switch
- 2. Fuel Pump
- 3. Fuel Pump Relay
- 4. ECU
- 5. Starter Relay
- 6. Main Fuse 20 A
- 7. Battery 12 V 6 Ah

- 8. Frame Ground
- 9. Fuse Box
- 10. Ignition Fuse 10 A
- 11. ECU Fuse 15 A
- 12. Starter Button
- 13. Engine Stop Switch

3-80 FUEL SYSTEM (DFI)

Ignition Coil (Service Code 51)

Ignition Coil Removal/Installation

- Refer to the Ignition Coil Removal/Installation in the Electrical System chapter.

Ignition Coil Input Voltage Inspection

NOTE

○ Be sure the battery is fully charged.

- Turn the ignition switch OFF.
- Remove the ECU (see ECU Removal).
- Do not disconnect the ECU connector.
- Connect a digital meter [A] to the connector [B] with the needle adapter set.

Special Tool - Needle Adapter Set: 57001-1457

Ignition Coil Input Voltage

Connections to ECU Connector:

Digital Meter (+) → O lead (terminal 18)

Digital Meter (-) → Battery (-) Terminal

- Measure the input voltage to each primary winding of the ignition coil with the engine stopped, and with the connector joined.
- Turn the engine stop switch to run position.
- Turn the ignition switch ON.

Input Voltage

Standard: Battery Voltage

- Turn the ignition switch OFF.
- ★ If the input voltage is out of the standard, check the wiring for continuity (see Ignition Coil Circuit).
- ★ If the wiring is good, check the ECU for its ground and power supply (see ECU Power Supply Inspection).
- ★ If the ground and power supply are good, replace the ECU (see ECU Removal/Installation).
- ★ If the input voltage is within the standard, check the ECU for its ground and power supply (see ECU Power Supply Inspection)
- ★ If the ground and power supply are good, replace the ECU (see ECU Removal/Installation).

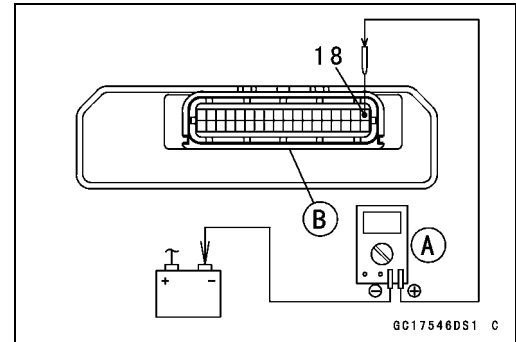

Ignition Coil (Service Code 51)

Ignition Coil Circuit

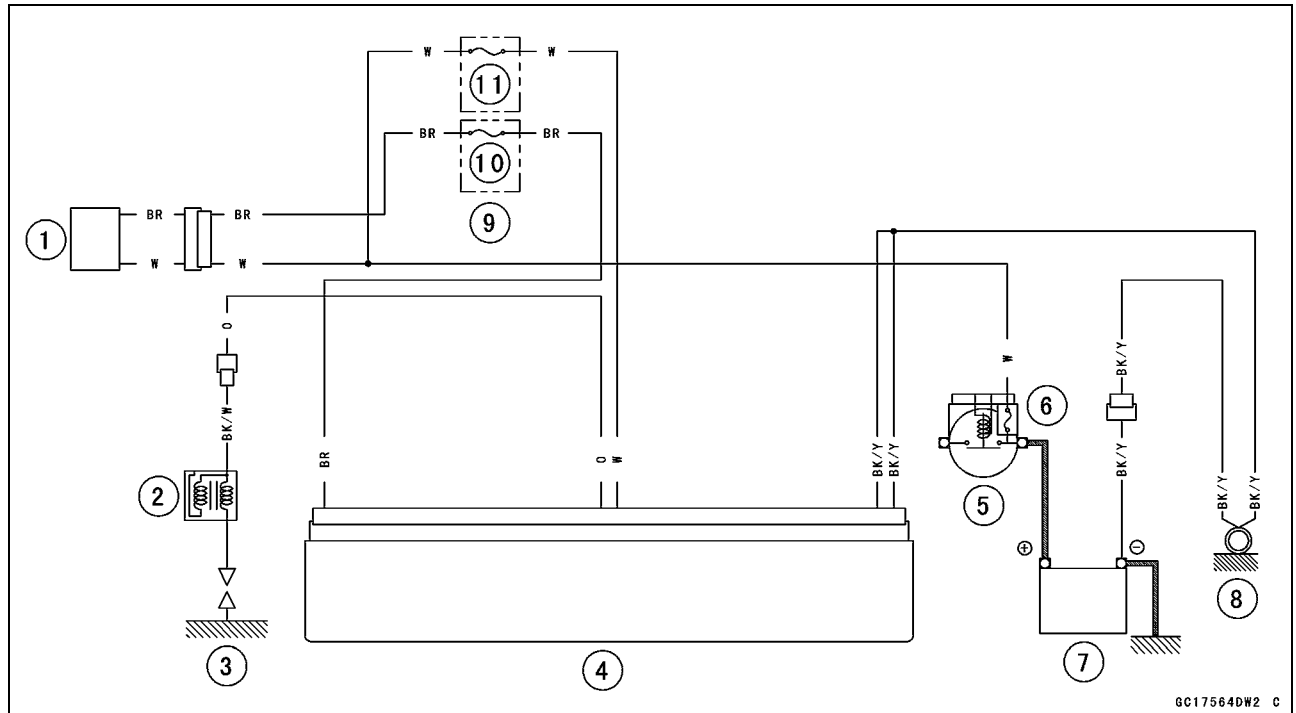

GC17564DW2 C

1. Ignition Switch
2. Ignition Coil
3. Spark Plug
4. ECU
5. Starter Relay
6. Main Fuse 20 A
7. Battery 12 V 6 Ah
8. Frame Ground
9. Fuse Box
10. Ignition Fuse 10 A
11. ECU Fuse 15 A

3-82 FUEL SYSTEM (DFI)

Radiator Fan Relay (Service Code 56)

Radiator Fan Relay Removal/Installation

- Refer to the Radiator Fan Relay Inspection in the Electrical System chapter.

Radiator Fan Relay Inspection

- Refer to the Radiator Fan Relay Inspection in the Electrical System chapter.
- ★ If the radiator fan relay is normal, check the wiring for continuity (see Radiator Fan Relay Circuit).
- ★ If the wiring is good, check the ECU for its ground and power supply (see ECU Power Supply Inspection).
- ★ If the ground and power supply are good, replace the ECU (see ECU Removal/Installation).

Radiator Fan Relay Circuit

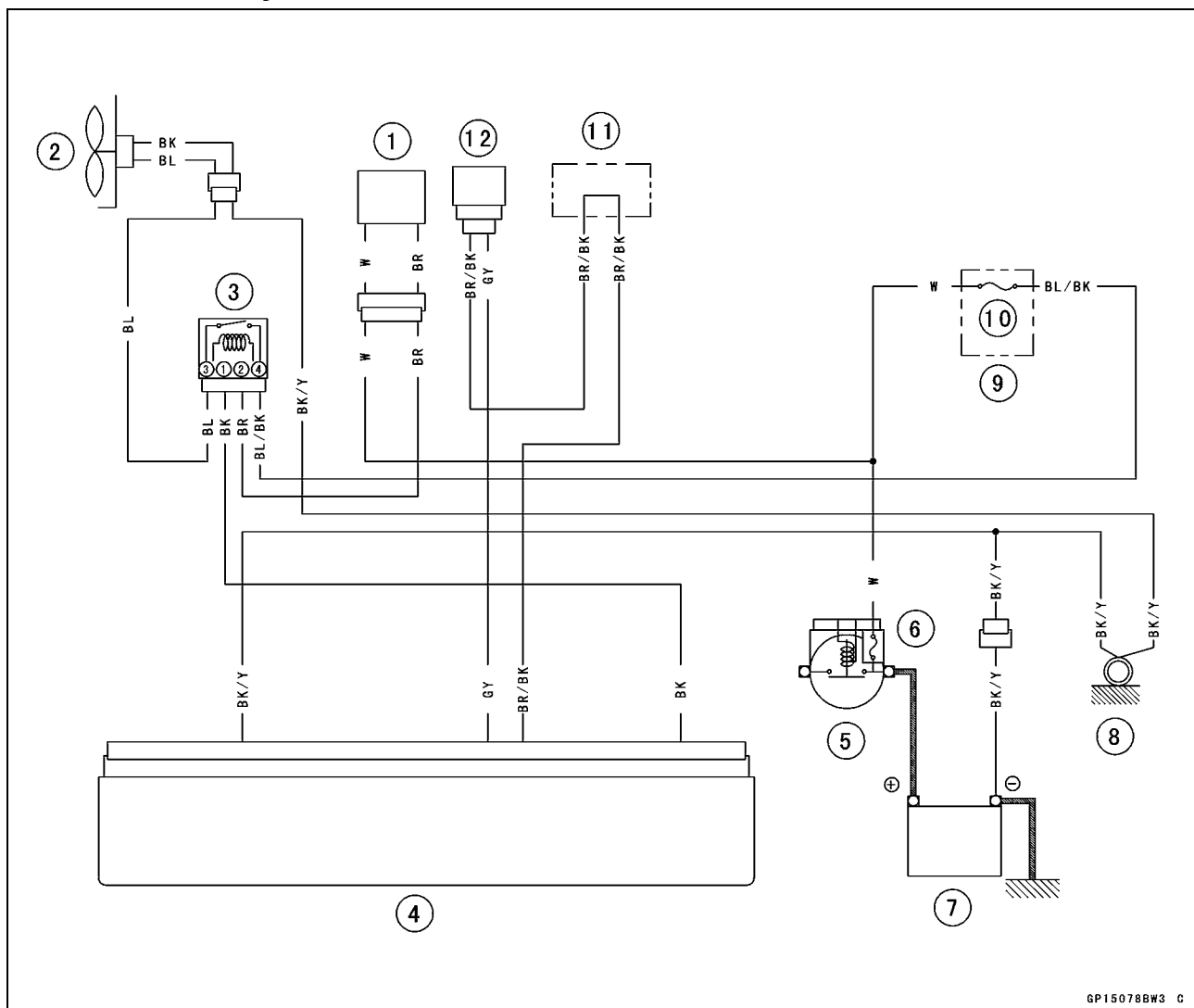

1. Ignition Switch
2. Radiator Fan
3. Fan Relay
4. ECU
5. Starter Relay
6. Main Fuse 20 A

7. Battery 12 V 6 Ah
8. Frame Ground
9. Fuse Box
10. Radiator Fan Fuse 10 A
11. Water-proof Joint
12. Water Temperature Sensor

Subthrottle Valve Actuator (Service Code 62: TH and EUR Models/Service Code 32: IN Model)

Subthrottle Valve Actuator Removal

NOTICE

Do not remove the subthrottle valve actuator [A] since it has been adjusted and set with precision at the factory.
Never drop the throttle body assy especially on a hard surface. Such a shock to the subthrottle valve actuator can damage it.

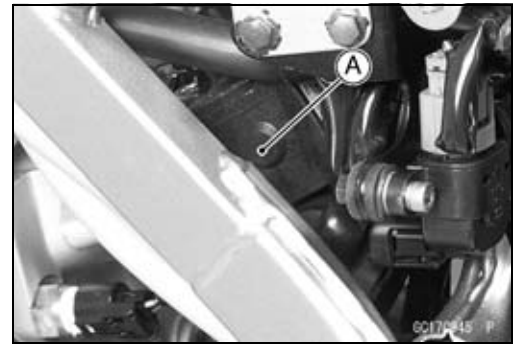

Subthrottle Valve Actuator Inspection

NOTE

○Be sure the battery is fully charged.

- Remove:
 - Right Side Cover (see Side Cover Remove in the Frame chapter)
 - Clamp Screws [A]
 - Air Cleaner Duct [B]
- Turn the ignition switch ON.
- Check to see that all the subthrottle valve [A] open and close smoothly.
- Turn the ignition switch OFF.
- ★ If the subthrottle valve do not operate, check the subthrottle valve actuator resistance (see Subthrottle Valve Actuator Resistance Inspection).

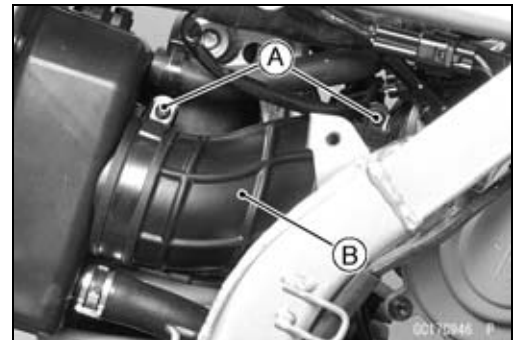

- When install the air cleaner duct, fit the air cleaner housing projection [A] to the air cleaner duct groove [B].
Torque - Front Air Cleaner Duct Clamp Screw: 2.0 N·m (0.20 kgf·m, 18 in·lb)

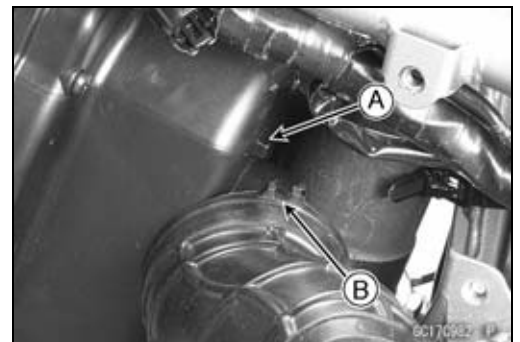

Subthrottle Valve Actuator Resistance Inspection

- Turn the ignition switch OFF.
- Disconnect the subthrottle valve actuator connector [A].



3-84 FUEL SYSTEM (DFI)

Subthrottle Valve Actuator (Service Code 62: TH and EUR Models/Service Code 32: IN Model)

- Connect a digital meter to the subthrottle valve actuator connector.
- Measure the subthrottle valve actuator resistance.

Subthrottle Valve Actuator Resistance

Connections: G lead [1] ↔ W/BL lead [2]

BK lead [3] ↔ P lead [4]

Standard: About 5.2 ~ 7.8 Ω

- ★ If the reading is out of the standard, replace the throttle body assy.
- ★ If the reading is within the standard, check the input voltage (see Subthrottle Valve Actuator Input Voltage Inspection).

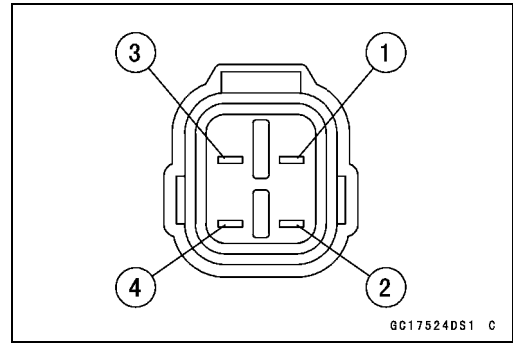

Subthrottle Valve Actuator Input Voltage Inspection

NOTE

○ Be sure the battery is fully charged.

- Turn the ignition switch OFF.
- Disconnect the subthrottle valve actuator connector and connect the harness adapter [A] between these connectors as shown.

Main Harness [B]

Subthrottle Valve Actuator [C]

Special Tool - Measuring Adapter: 57001-1700

- Connect the peak voltage adapter [D] and a digital meter [E] to the harness adapter leads.

Special Tool - Peak Voltage Adapter: 57001-1415

Type: KEK-54-9-B

Subthrottle Valve Actuator Input Voltage

Connections to Adapter:

(I) Digital Meter (+) → R (actuator G) lead

Digital Meter (-) → Battery (-) Terminal

(II) Digital Meter (+) → BK (actuator W/BL) lead

Digital Meter (-) → Battery (-) Terminal

(III) Digital Meter (+) → W (actuator BK) lead

Digital Meter (-) → Battery (-) Terminal

(IV) Digital Meter (+) → Y (actuator P) lead

Digital Meter (-) → Battery (-) Terminal

- Measure the actuator input voltage with the engine stopped and with the connector joined.
- Turn the ignition switch ON.

Input Voltage

Standard: About DC 10.5 ~ 12.5 V, and then 0 V

- Turn the ignition switch OFF.
- ★ If the reading is in specification, but the actuator does not operate, replace the throttle body assy.

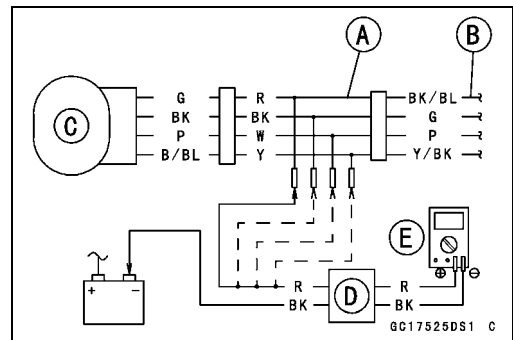
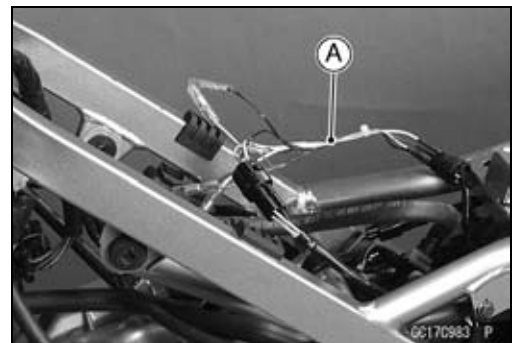

Subthrottle Valve Actuator (Service Code 62: TH and EUR Models/Service Code 32: IN Model)

★ If the reading is out of the specification, remove the ECU and check the wiring for continuity between main harness connectors.

○ Disconnect the ECU and actuator connectors.

Wiring Inspection

ECU Connector [A] ↔

Subthrottle Valve Actuator Connector [B]

G/Y lead (ECU terminal 14) [C]

Y/BL lead (ECU terminal 32) [D]

BK/BL lead (ECU terminal 15) [E]

P lead (ECU terminal 31) [F]

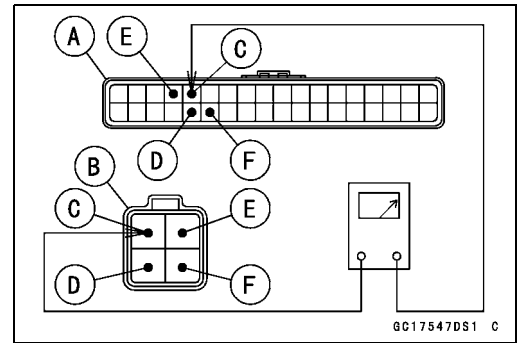

★ If the wiring is good, check the ECU for its ground and power supply (see ECU Power Supply Inspection).

★ If the ground and power supply are good, replace the ECU (see ECU Removal/Installation).

Subthrottle Valve Actuator Circuit

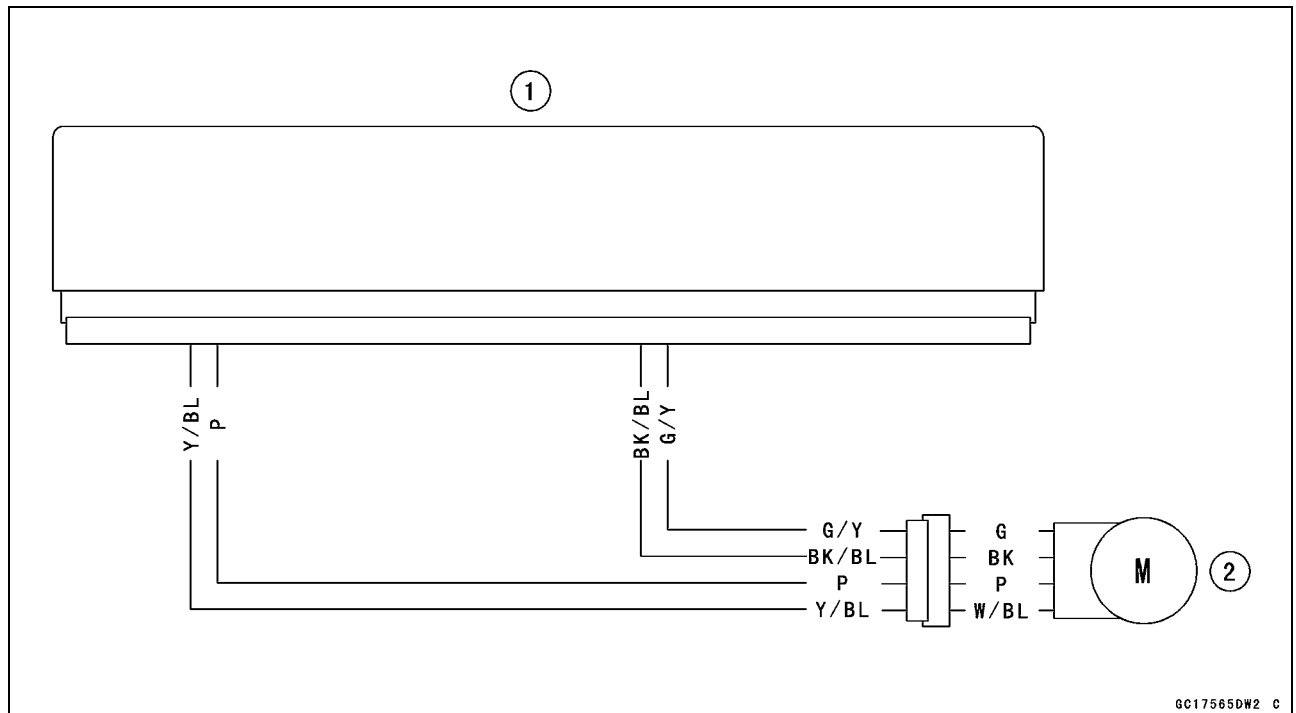

1. ECU

2. Subthrottle Valve Actuator

3-86 FUEL SYSTEM (DFI)

Air Switching Valve (Service Code 64)

Air Switching Valve Removal/Installation

- Refer to the Air Switching Valve Removal/Installation in the Engine Top End chapter.

Air Switching Valve Inspection

- Refer to the Air Switching Valve Unit Test in the Electrical System chapter.
- ★ If the air switching valve is normal, check the wiring for continuity (see wiring diagram in this section).
- ★ If the wiring is good, check the ECU for its ground and power supply (see ECU Power Supply Inspection).
- ★ If the ground and power supply are good, replace the ECU (see ECU Removal/Installation).

Air Switching Valve Circuit

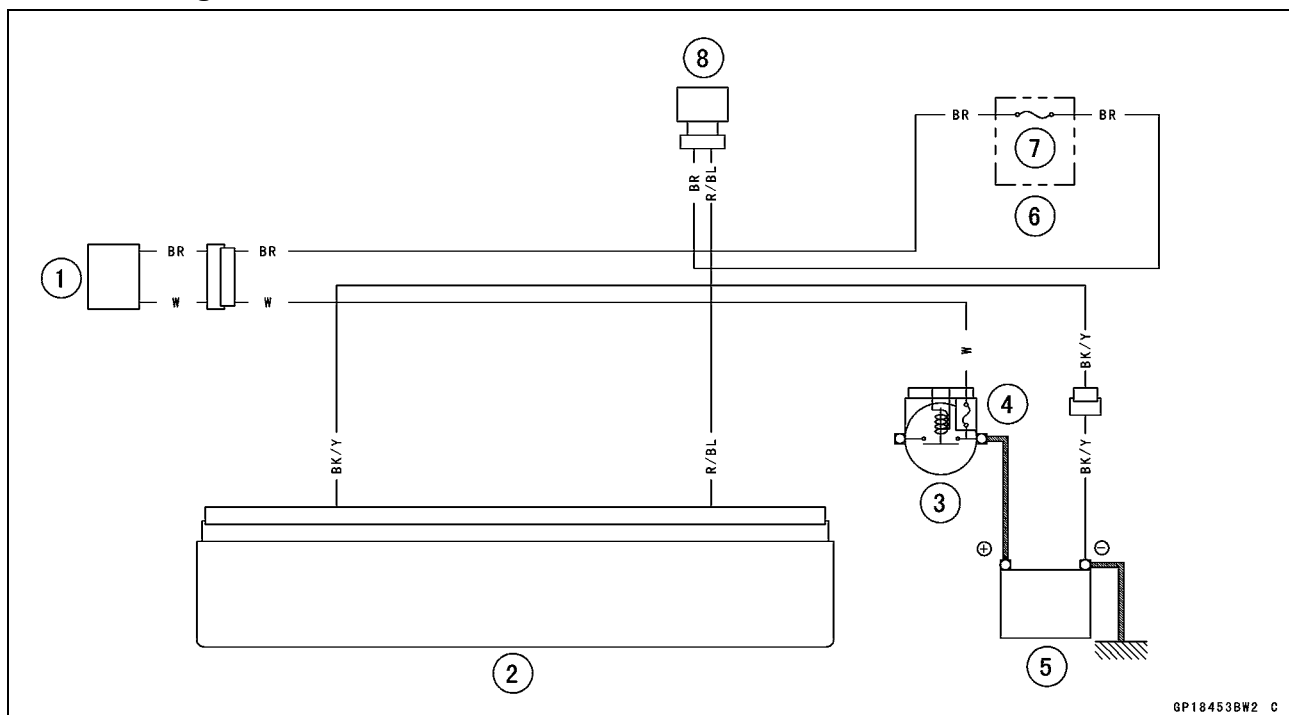

1. Ignition Switch
2. ECU
3. Starter Relay
4. Main Fuse 20 A
5. Battery 12 V 6 Ah
6. Fuse Box
7. Ignition Fuse 10 A
8. Air Switching Valve

Oxygen Sensor Heater (Service Code 67)

Oxygen Sensor Heater Removal/Installation

The oxygen sensor heater is built in the oxygen sensor. So, the heater itself can not be removed. Remove the oxygen sensor (see Oxygen Sensor Removal in the Electrical System chapter).

Oxygen Sensor Heater Resistance Inspection

- Turn the ignition switch OFF.
- Remove:
 - Seat (see Seat Removal in the Frame chapter)
- Pull the oxygen sensor lead connector [A] from the frame bracket.
- Disconnect the connector.



- Connect a digital meter [A] to the oxygen sensor lead connector [B].
- Measure the oxygen sensor heater resistance.

Oxygen Sensor Heaters Resistance

Connections: W lead [C] ↔ W lead [D]

Standard: 6.7 ~ 10.5 Ω at 20° C (68°F)

- ★ If the reading is out of the standard, replace the sensor.
- ★ If the reading is within the standard, check the power supply voltage (see Oxygen Sensor Heater Power Supply Voltage Inspection).

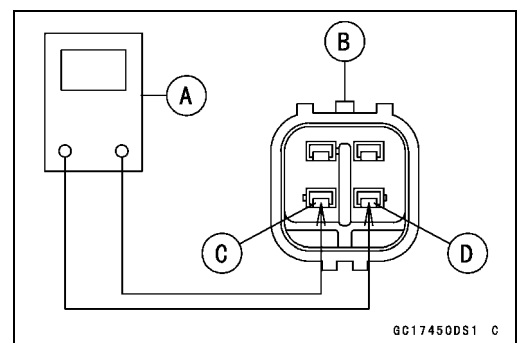

Oxygen Sensor Heater Power Source Voltage Inspection

NOTE

○ Be sure the battery is fully charged.

- Turn the ignition switch OFF.
- Disconnect the oxygen sensor lead connector and connect the harness adapter [A] between these connectors.

Special Tool - Measuring Adapter: 57001-1700

- Connect a digital meter [B] to the harness adapter lead. Oxygen Sensor [C]

Oxygen Sensor Power Source Voltage

Connections to Adapter:

Digital Meter (+) → R (main harness BR) lead

Digital Meter (-) → Battery (-) terminal

- Measure the power source voltage with the engine stopped and with the connector joined.
- Turn the ignition switch ON.

Power Source Voltage

Standard: Battery Voltage

- Turn the ignition switch OFF.
- ★ If the reading is in specification, but the problem still exists, replace the ECU (see ECU Removal/Installation).
- ★ If the reading is out of the standard, check the following. Power Source Wiring (see Oxygen Sensor Circuit)

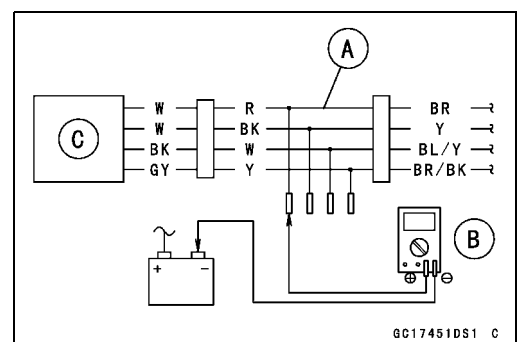
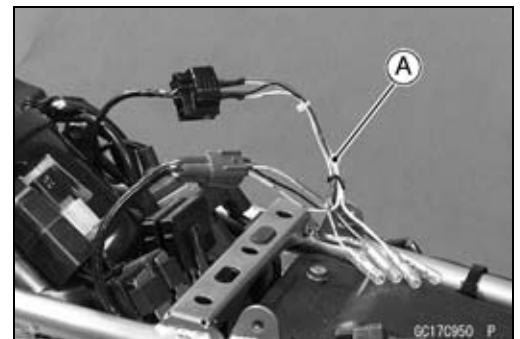

3-88 FUEL SYSTEM (DFI)

Oxygen Sensor Heater (Service Code 67)

- ★ If the wiring is good, remove the ECU and check the wiring for continuity between main harness connectors.
- Disconnect the ECU and sensor connectors.

Wiring Inspection

ECU Connector [A] ↔

Oxygen Sensor Connector [B]

Y lead (ECU terminal 17) [C]

- ★ If the wiring is good, check the ECU for its ground and power supply (see ECU Power Supply Inspection).
- ★ If the ground and power supply are good, replace the ECU (see ECU Removal/Installation).

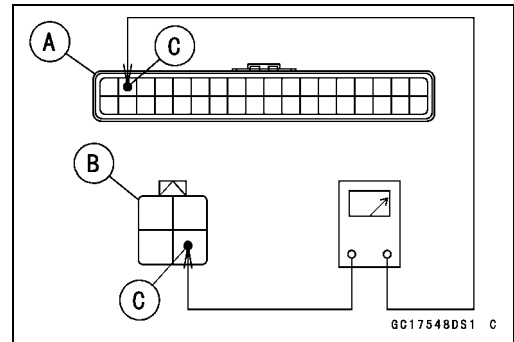

Oxygen Sensor Circuit

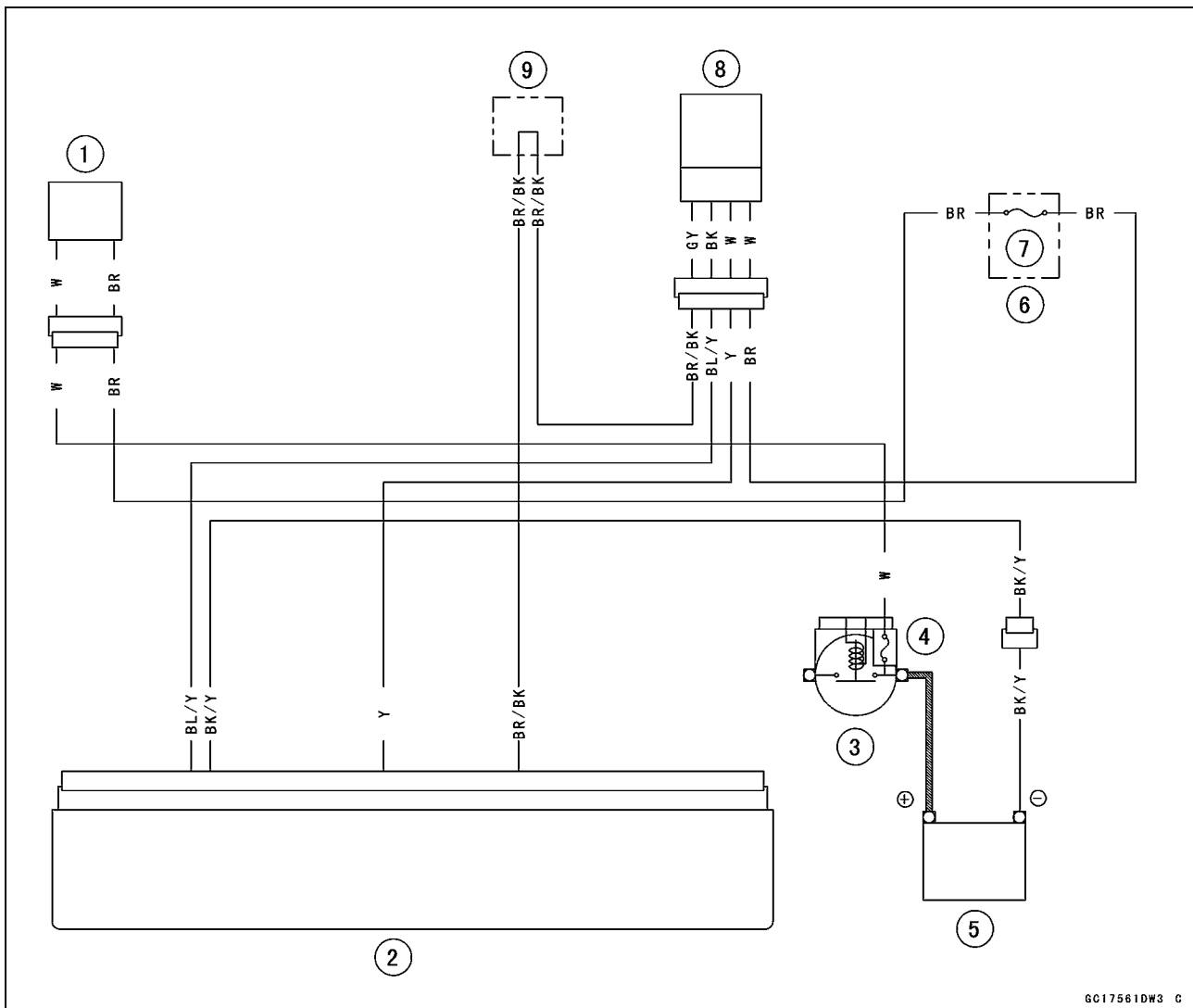

1. Ignition Switch
2. ECU
3. Starter Relay
4. Main Fuse 20 A
5. Battery 12 V 6 Ah
6. Fuse Box
7. Ignition Fuse 10 A
8. Oxygen Sensor
9. Water-proof Joint

FI Indicator Light (LED)

FI Indicator Light (LED) Inspection

- In this model, the FI indicator light (LED) [A] blink by the data sent from the ECU.
- Refer to the Meter Unit Inspection in the Electrical System chapter for the FI indicator light (LED) inspection.

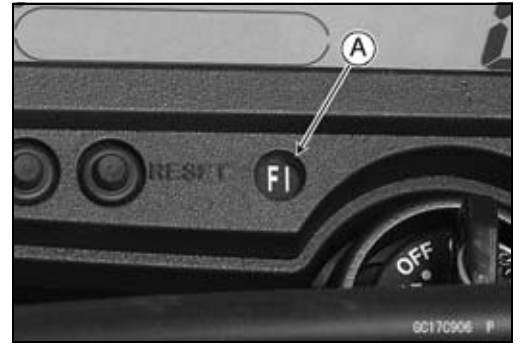

FI Indicator Light (LED) Circuit

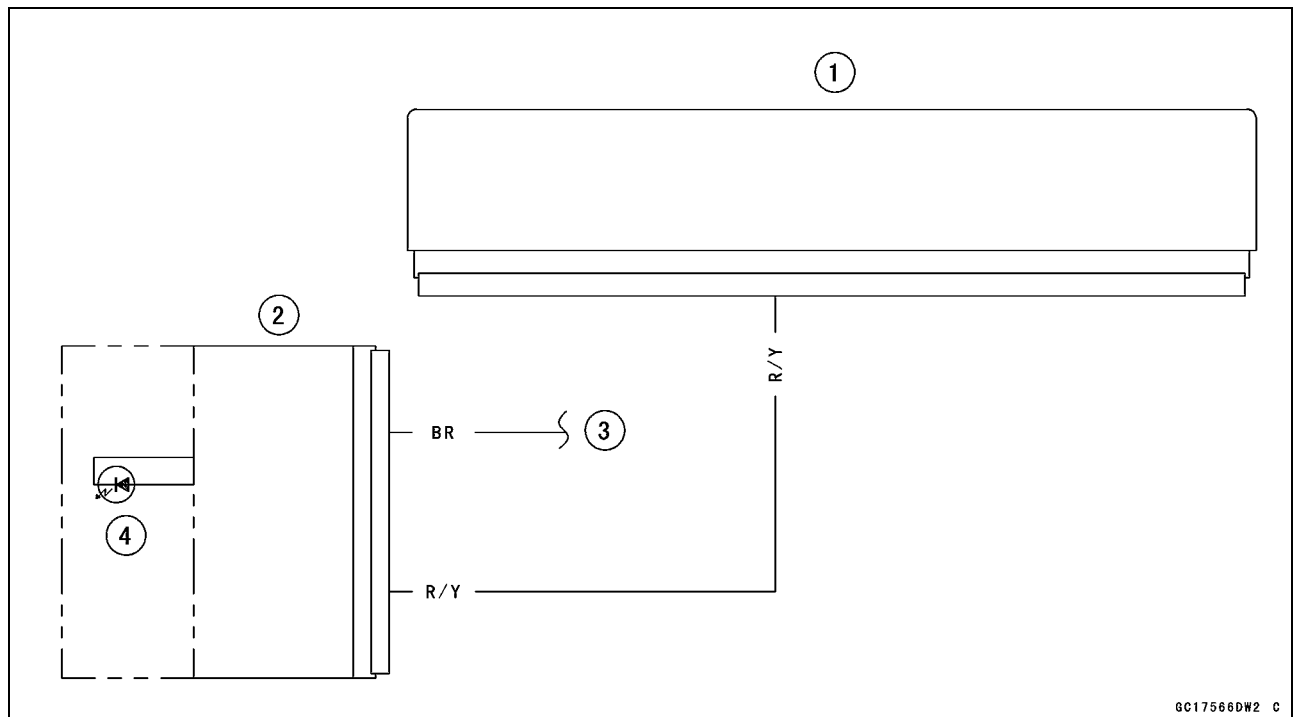

1. ECU
2. Meter Unit
3. Ignition Switch
4. FI Indicator Light (LED)

3-90 FUEL SYSTEM (DFI)

FI Indicator Light (LED)

Inspection Flow Chart

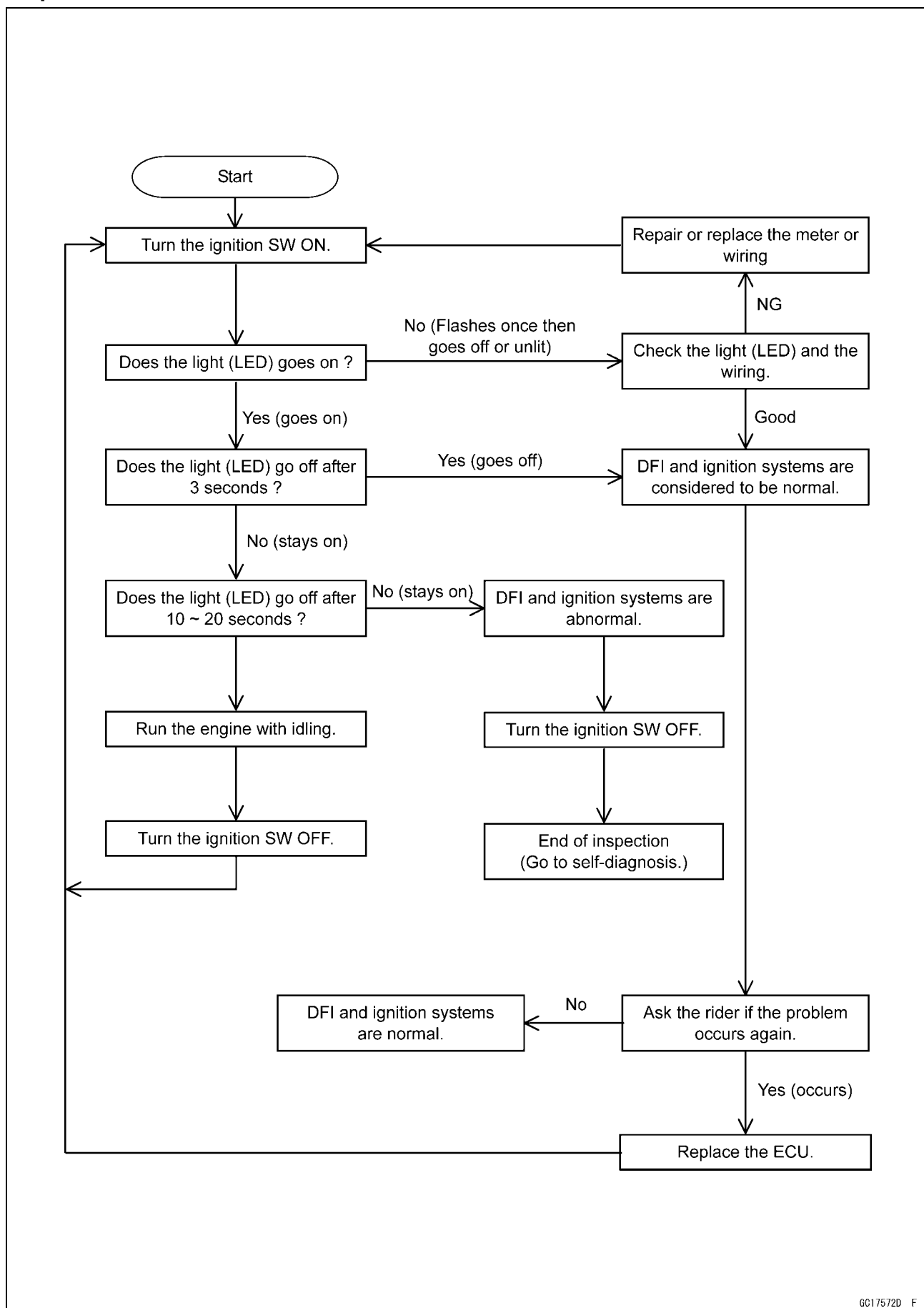

ECU

ECU Identification

○Most countries have their own regulations, so each ECU has different characteristic. So, do not confuse ECU with each other and use only the ECU for your model. Otherwise, the motorcycle can not clear the regulation.

ECU Identification

Part Number [A]	Specification
21175-0167	EUR (KLX250S9F)
	TH (KLX250S9F Early Model)
21175-0168	TH (KLX250V9F Early Model)
21175-0224	IN (KLX250S9F)
21175-0239	IN (KLX250V9F)
21175-0286	BR
21175-0304	SEA (KLX250SAF)
	EUR (KLX250SAF)
	TH (KLX250S9F Late Model ~ SAF)
21175-0305	TH (KLX250V9F Late Model ~ VAF)
21175-0306	IN (KLX250SAF)
21175-0307	IN (KLX250VAF)
21175-0359	IN (KLX250SBF)
21175-0360	SEA (KLX250SBF)
	EUR (KLX250SBF)
	TH (KLX250SBF)

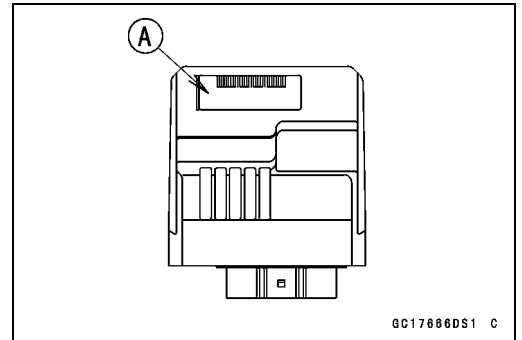

ECU Removal

NOTICE

Never drop the ECU especially on a hard surface. Such a shock to the ECU can damage it.

- Remove:
 - Left Side Cover (see Side Cover Removal in the Frame chapter)
- Pull the ECU [A] together with rubber protector.

- Remove:
 - ECU Connector [A]
 - ECU [B]

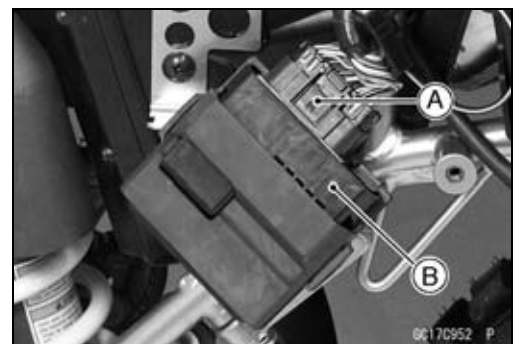
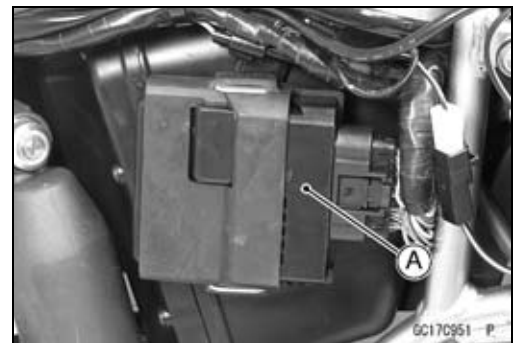

3-92 FUEL SYSTEM (DFI)

ECU

ECU Installation

- Install the ECU [B] to the rubber protector [A].
- Connect the ECU connector.

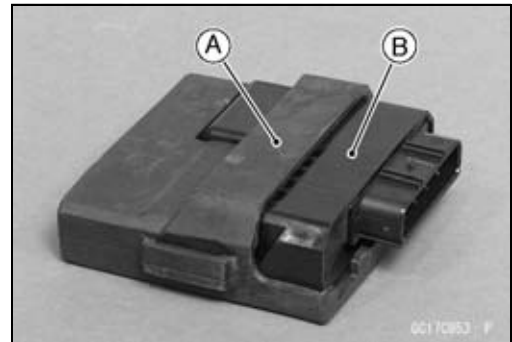

- Insert the slits [A] of the rubber protector to the air cleaner housing bracket.

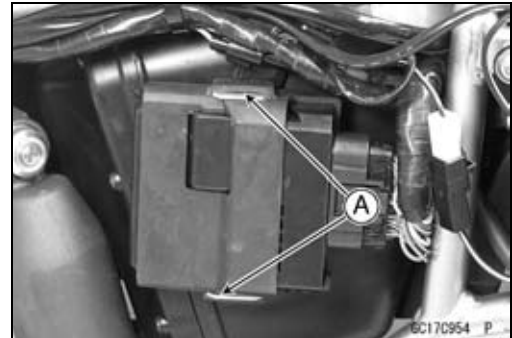

ECU Power Supply Inspection

- Remove the left side cover (see Side Cover Removal in the Frame chapter).
 - Visually inspect the ECU connectors.
 - ★ If the connector is clogged with mud or dust, blow it off with compressed air.
 - Remove the ECU (see ECU Removal).
 - Visually inspect the terminals [A] of the ECU connectors.
 - ★ If the terminals of the main harness connector are damaged, replace the main harness.
 - ★ If the terminals of the ECU connector are damaged, replace the ECU.
- Turn the ignition switch OFF.
 - Disconnect the ECU connectors [A].
 - Set the hand tester [B] to the $\times 1 \Omega$ range and check the following wiring for continuity.



Special Tool - Hand Tester: 57001-1394

ECU Grounding Inspection

Connections:

(I) BK/Y leads (ECU terminal 8, 35 or 36) \longleftrightarrow Battery (-) Terminal

(II) Engine Ground \longleftrightarrow Battery (-) Terminal

Criteria:

Both: 0 Ω

- ★ If no continuity, check the connector, engine ground lead, or main harness, and repair or replace them if necessary.

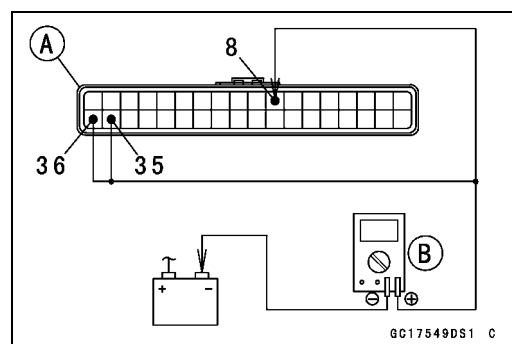

ECU

★ If the wiring is good, check the power supply voltage of the ECU.

NOTE

○ Be sure the battery is fully charged.

- Connect the ECU connector.
- Connect a digital meter [A] to the connector [B] with the needle adapter set.

Special Tool - Needle Adapter Set: 57001-1457

ECU Power Supply Inspection

Connections:

- (I) Digital Meter (+) → Terminal 1 (BR lead)
Digital Meter (-) → Battery (-) terminal
- (II) Digital Meter (+) → Terminal 19 (W lead)
Digital Meter (-) → Battery (-) terminal

Ignition Switch OFF:

- Terminal 1 (BR lead): DC 0 V
- Terminal 19 (W lead): Battery Voltage

Ignition Switch ON:

Both: Battery Voltage

★ If the reading is out of the specification, check the following.

- Main Fuse 20 A (see Fuse Inspection in the Electrical System chapter)
- ECU Fuse 15 A (see Fuse Inspection in the Electrical System chapter)
- Power Supply Wiring (see ECU Power Supply Circuit)

★ If the fuse, wiring and relay are good, replace the ECU (see ECU Removal/Installation).

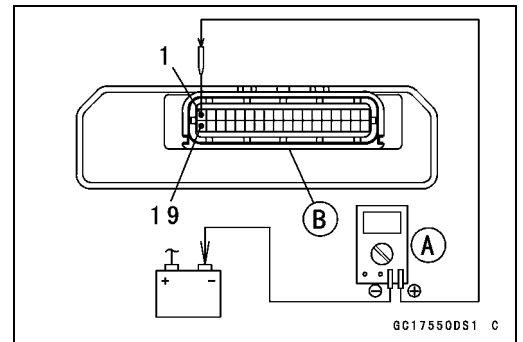

3-94 FUEL SYSTEM (DFI)

ECU

ECU Power Supply Circuit

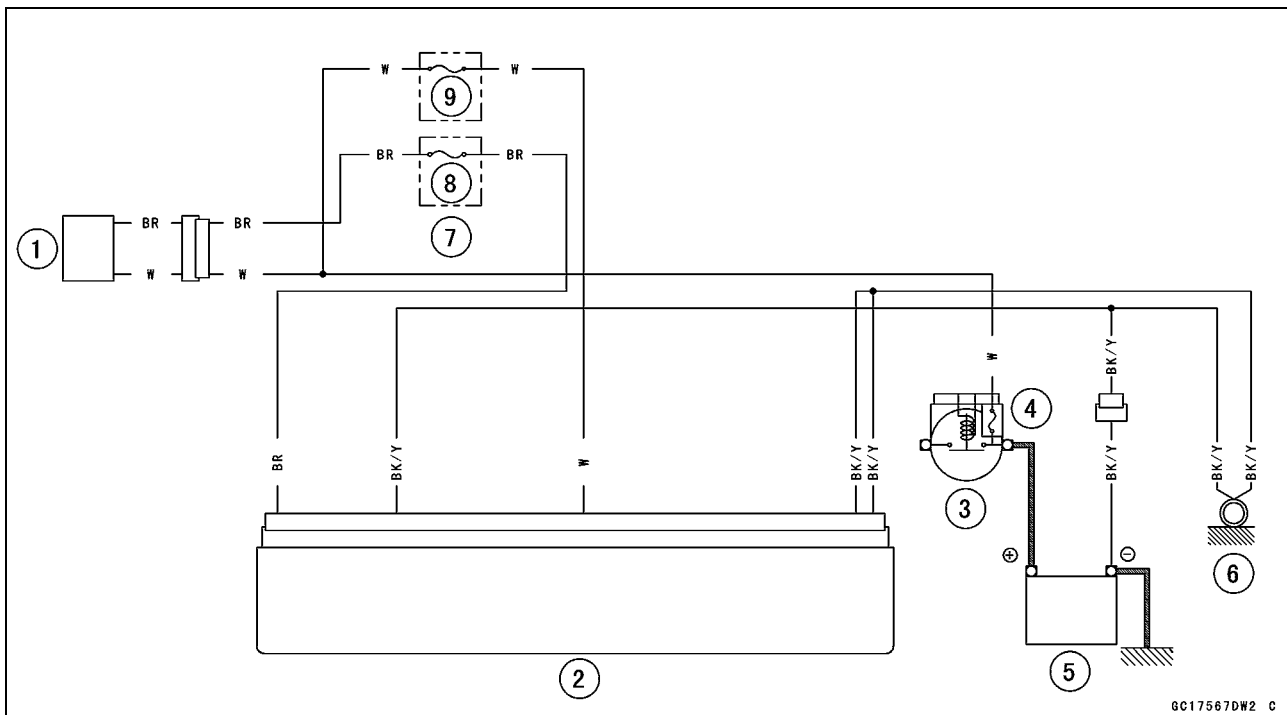

1. Ignition Switch
2. ECU
3. Starter Relay
4. Main Fuse 20 A
5. Battery 12 V 6 Ah
6. Frame Ground
7. Fuse Box
8. Ignition Fuse 10 A
9. ECU Fuse 15 A

DFI Power Source

ECU Fuse Removal

- Refer to the Fuse Box Fuse Removal in the Electrical System chapter.

ECU Fuse Installation

- ★ If a fuse fails during operation, inspect the DFI system to determine the cause, and then replace it with a new fuse of proper amperage.
- Refer to the Fuse Installation in the Electrical System chapter.

ECU Fuse Inspection

- Refer to the Fuse Inspection in the Electrical System chapter.

3-96 FUEL SYSTEM (DFI)

Fuel Line

Fuel Pressure Inspection

NOTE

○Be sure the battery is fully charged.

- Remove:
 - Fuel Tank (see Fuel Tank Removal)
 - Fuel Outlet Hose (see Fuel Injector Removal)
- Be sure to place a piece of cloth around the fuel outlet pipe of the fuel pump and the delivery pipe of the throttle body assy.

⚠ WARNING

Fuel is flammable and explosive under certain conditions and can cause severe burns. Be prepared for fuel spillage; any spilled fuel must be completely wiped up immediately. When the fuel hose is disconnected, fuel spills out from the hose and the pipe because of residual pressure. Cover the hose connection with a piece of clean cloth to prevent fuel spillage.

- Install the fuel pressure gauge adapter [A] and fuel hoses (Special Tool: 57001-1607) [B] between the fuel outlet pipe and delivery pipe.
- Secure the fuel hoses with the clamps.
- Connect the pressure gauge [C] to the fuel pressure gauge adapter.

Special Tools - Oil Pressure Gauge, 5 kgf/cm²: 57001-125
Fuel Pressure Gauge Adapter: 57001-1593
Fuel Hose: 57001-1607

⚠ WARNING

Fuel is extremely flammable and can be explosive under certain conditions resulting in serious injury or death.
Do not try to start the engine with the fuel hoses disconnected.

- Connect:
 - Fuel Pump Lead Connector [D]
- Turn the engine stop switch run position.
- Turn the ignition switch ON.
- The fuel pump should operate for 3 seconds, and then should stop.

NOTE

○After turning on the engine stop switch and ignition switch, inspect the fuel leakage from the connected portion of the special tools.

NOTICE

Do not drive the fuel pump 3 seconds or more without the fuel in the fuel tank. If the fuel pump is driven without the fuel, it may be damaged.

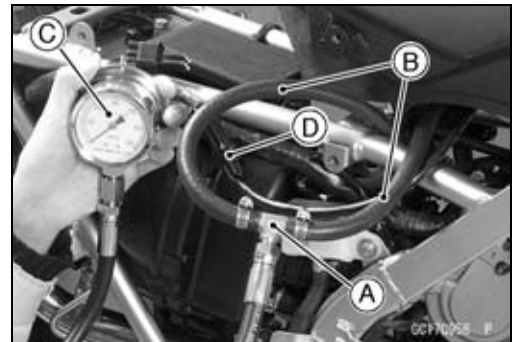

Fuel Line

- Start the engine, and let it idle.
- Measure the fuel pressure with the engine idling.

Fuel Pressure (with Engine Idling)

Standard: 294 kPa (3.0 kgf/cm², 43 psi)

NOTE

○ *The gauge needle will fluctuate. Read the pressure at the average of the maximum and minimum indications.*

- Turn the ignition switch OFF.
- ★ If the fuel pressure is much higher than specified, replace the fuel pump because the fuel pressure regulator in the fuel pump have been clogged or stuck.
- ★ If the fuel pressure is much lower than specified, check the following.
 - Fuel Line Leakage (see Injector Fuel Line Inspection)
 - Amount of Fuel Flow (see Fuel Flow Rate Inspection)
- After above checks, measure the fuel pressure again.
- Remove the fuel pressure gauge, hoses and adapter.
- Install:
 - Fuel Outlet Hose (see Fuel Injector Installation)
 - Fuel Tank (see Fuel Tank Installation)
- Start the engine and check for fuel leakage.

Fuel Flow Rate Inspection

WARNING

Gasoline is extremely flammable and can be explosive under certain conditions, creating the potential for serious burns. Make sure the area is well-ventilated and free from any source of flame or sparks; this includes any appliance with a pilot light. Do not smoke. Turn the ignition switch OFF. Be prepared for fuel spillage; any spilled fuel must be completely wiped up immediately.

NOTE

○ *Be sure the battery is fully charged.*

- Turn the ignition switch OFF.
- Wait until the engine cools down.
- Prepare a fuel hose (Special Tool: 57001-1607) and a measuring cylinder.
 - Special Tool - Fuel Hose: 57001-1607**
- Remove the fuel tank bolts (see Fuel Tank Removal).
- Remove the left radiator shroud (see Radiator Shroud Removal in the Frame chapter).

3-98 FUEL SYSTEM (DFI)

Fuel Line

- Open the fuel tank cap [A] to lower the pressure in the tank.
- Remove the fuel outlet hose from the fuel pump (see Fuel Tank Removal).
- Be sure to place a piece of cloth around the fuel outlet pipe of the fuel pump.

⚠ WARNING

Fuel is flammable and explosive under certain conditions and can cause severe burns. Be prepared for fuel spillage; any spilled fuel must be completely wiped up immediately. When the fuel hose is disconnected, fuel spills out from the hose and the pipe because of residual pressure. Cover the hose connection with a piece of clean cloth to prevent fuel spillage.

- Connect the prepared fuel hose [A] to the fuel outlet pipe.
- Secure the fuel hose with a clamp.
- Insert the fuel hose into the measuring cylinder [B].

⚠ WARNING

Wipe off spilled out fuel immediately. Be sure to hold the measuring cylinder vertical.

- Close the fuel tank cap.
- Turn the engine stop switch to run position.
- Turn the ignition switch ON.
- The fuel pump should operate for 3 seconds, and then should stop.

NOTICE

Do not drive the fuel pump 2 seconds or more without the fuel in the fuel tank. If the fuel pump is driven without the fuel, it may be damaged.

- Measure the discharge for 2 seconds.
- Repeat this operation several times.

Amount of Fuel Flow

Standard: 11 mL (0.37 US oz.) or more for 2 seconds

- Turn the ignition switch OFF.
- ★ If the fuel flow is much less than the specified, replace the fuel pump (see Fuel Pump Removal/Installation).
- Install the fuel tank (see Fuel Tank Installation).
- Start the engine and check for fuel leakage.

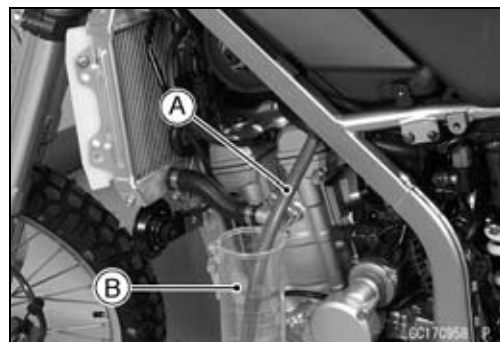

Fuel Pump

Fuel Pump Removal

⚠ WARNING

Gasoline is extremely flammable and can be explosive under certain conditions, creating the potential for serious burns. Make sure the area is well-ventilated and free from any source of flame or sparks; this includes any appliance with a pilot light. Do not smoke. Turn the ignition switch OFF. Disconnect the battery (–) terminal. To avoid fuel spills, draw it from the tank when the engine is cold. Be prepared for fuel spillage; any spilled fuel must be completely wiped up immediately.

NOTICE

Never drop the fuel pump especially on a hard surface. Such a shock to the pump can damage it.

- Draw the fuel out from the fuel tank with a commercially available electric pump.
- Remove the fuel tank (see Fuel Tank Removal).
- Be careful of fuel spillage from the fuel tank since fuel still remains in the fuel tank and fuel pump. Plug the fuel pipe of the fuel tank.
- Turn the fuel tank upside down.
- Remove the fuel inlet hose [A].
- Unscrew the fuel pump bolts [B], and take out the fuel pump [C].

NOTICE

Do not pull the leads of the fuel pump. If they are pulled, the lead terminals may be damaged.

- Discard the fuel pump gasket [A].

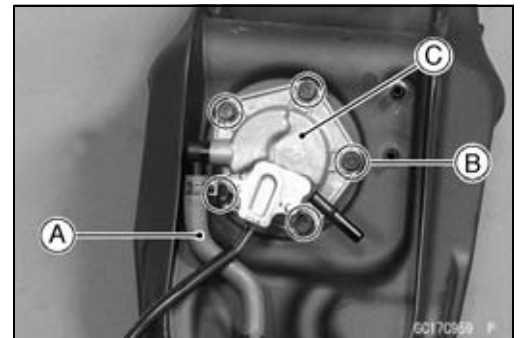

3-100 FUEL SYSTEM (DFI)

Fuel Pump

Fuel Pump Installation

- Remove the dirt or dust from the fuel pump [A] by lightly applying compressed air.
- Replace the fuel pump gasket with a new one.
- Apply a non-permanent locking agent to the threads of the fuel pump bolts.
- Tighten:
 - **Torque - Fuel Pump Bolts: 9.8 N·m (1.0 kgf·m, 87 in·lb)**
- Tighten the pump bolts again to check the tightness.

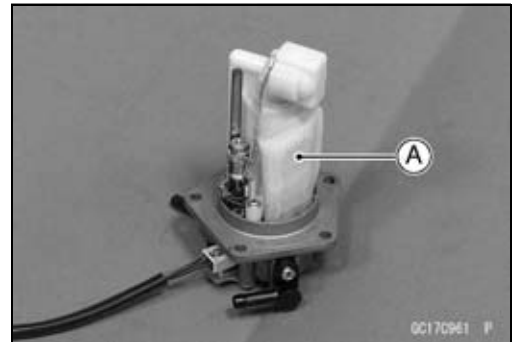

Fuel Pump Operation Inspection

NOTE

○ *Be sure the battery is fully charged.*

- Turn the engine stop switch to run position.
- Turn the ignition switch ON and make sure that the fuel pump operates (make light sounds) for 3 seconds, and then stops.
- Turn the ignition switch OFF.
- ★ If the pump does not operate as described above, check the operating voltage (see Fuel Pump Operating Voltage Inspection).

Fuel Pump

Fuel Pump Operating Voltage Inspection

NOTE

○Be sure the battery is fully charged.

- Turn the ignition switch OFF.
- Remove the right side cover (see Side Cover Removal in the Frame chapter).
- Disconnect the fuel pump lead connector [A] and connect the harness adapter [A] between these connectors as shown.

Main Harness [B]
Fuel Pump [C]

Special Tool - Measuring Adapter: 57001-1700

- Connect a digital meter [D] to the harness adapter leads.

Fuel Pump Operating Voltage

Connections to Adapter:

Digital Meter (+) → R (pump R) lead

Digital Meter (-) → BK (pump BK) lead

- Measure the operating voltage with engine stopped and with the connector joined.
- Turn the engine stop switch run position.
- Turn the ignition switch ON.

Operating Voltage

Standard: Battery Voltage for 2 seconds, and then 0 V

- Turn the ignition switch OFF.
- ★ If the reading stays on battery voltage and never shows 0 V, check the fuel pump relay (see Fuel Pump Relay Inspection).
- ★ If the pump relay is normal, check the ECU for its ground and power supply (see ECU Power Supply Inspection).
- ★ If the ground and power supply are good, replace the ECU (see ECU Removal/Installation).
- ★ If there is still no battery voltage, check the fuel pump relay (see Fuel Pump Relay Inspection).
- ★ If the fuel pump relay is normal, check the wiring for continuity (see Fuel Pump Circuit).
- ★ If the wiring is good, check the ECU for its ground and power supply (see ECU Power Supply Inspection).
- ★ If the ground and power supply are good, replace the ECU (see ECU Removal/Installation).
- ★ If the reading is in specification, but the fuel pump does not operate, replace the fuel pump (see Fuel Pump Removal/Installation).

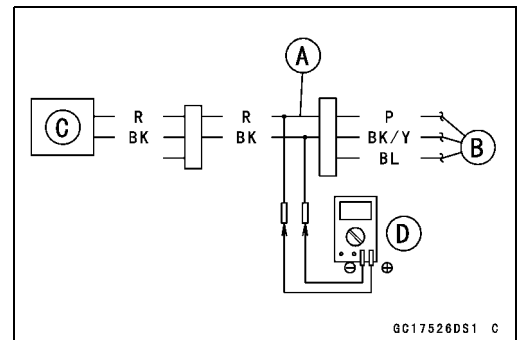
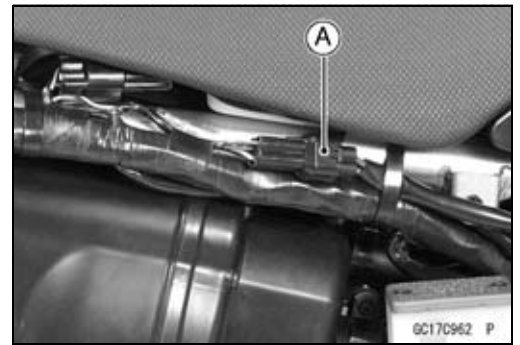

3-102 FUEL SYSTEM (DFI)

Fuel Pump

Pressure Regulator Removal

○The pressure regulator [A] is built into the fuel pump [B] and can not be removed.

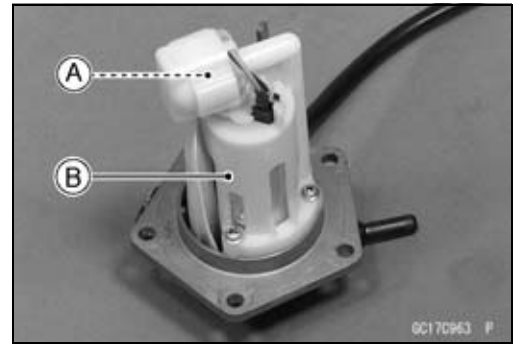

Fuel Filter Cleaning

○The fuel filter [A] is built into the pump and can not be cleaned or checked.

★If the fuel filter is suspected of clogging or being damaged, replace it with the fuel pump as a set.

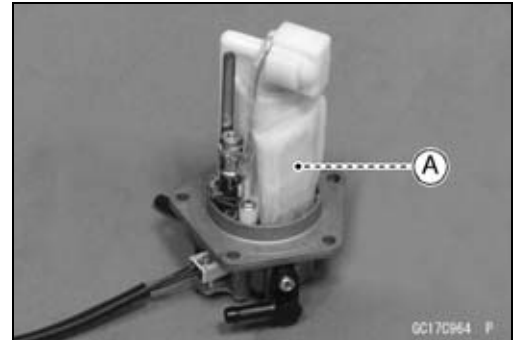

Fuel Pump

Fuel Pump Circuit

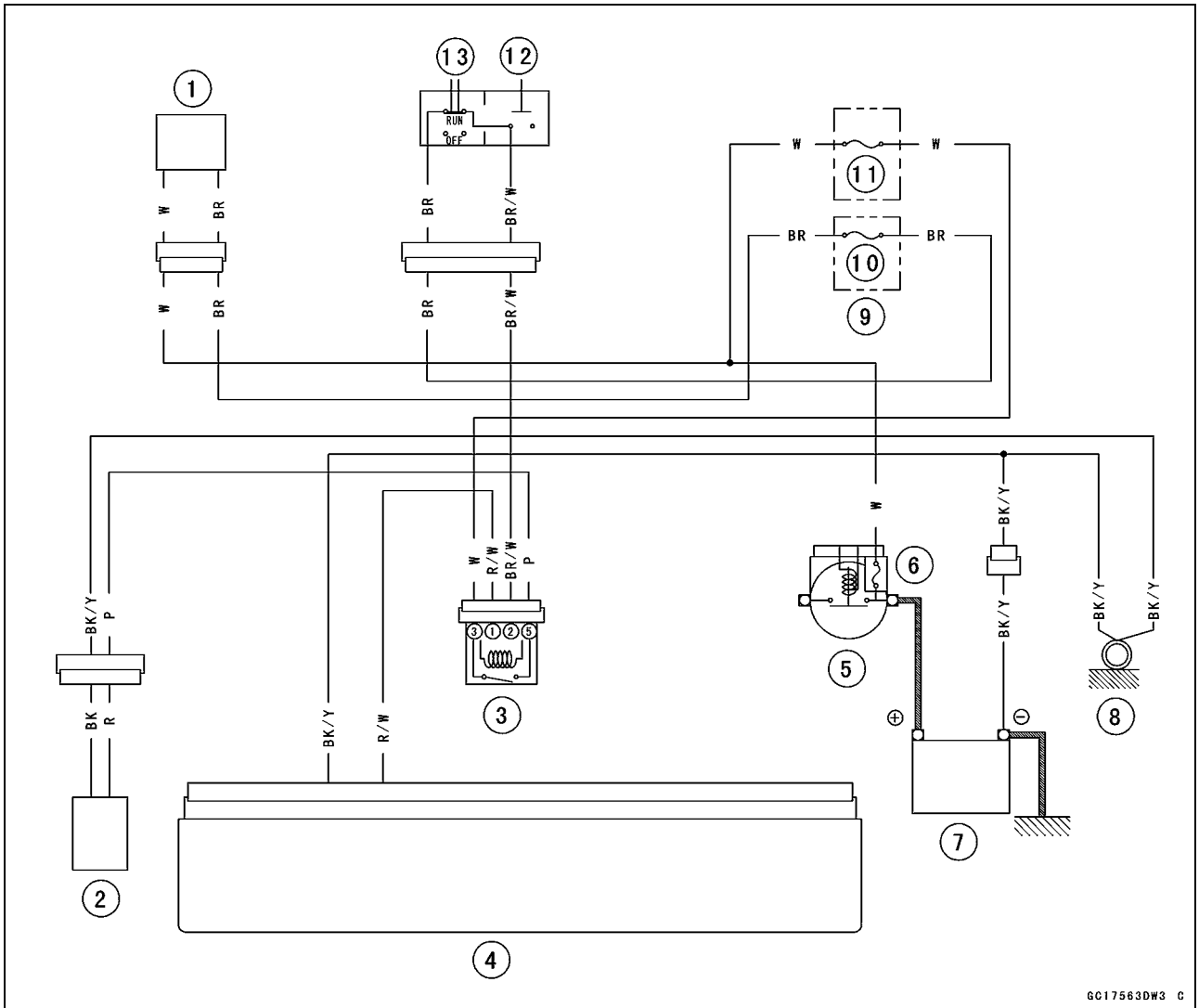

GC17563DW3 C

1. Ignition Switch
2. Fuel Pump
3. Fuel Pump Relay
4. ECU
5. Starter Relay
6. Main Fuse 20 A
7. Battery 12 V 6 Ah
8. Frame Ground
9. Fuse Box
10. Ignition Fuse 10 A
11. ECU Fuse 15 A
12. Starter Button
13. Engine Stop Switch

3-104 FUEL SYSTEM (DFI)

Throttle Grip and Cables

Throttle Grip Free Play Inspection

- Refer to the Throttle Control System Inspection in the Periodic Maintenance chapter.

Throttle Grip Free Play Adjustment

- Refer to the Throttle Control System Inspection in the Periodic Maintenance chapter.

Throttle Cable Remove

- Remove the screws [A].
- Separate the right switch housing [B].

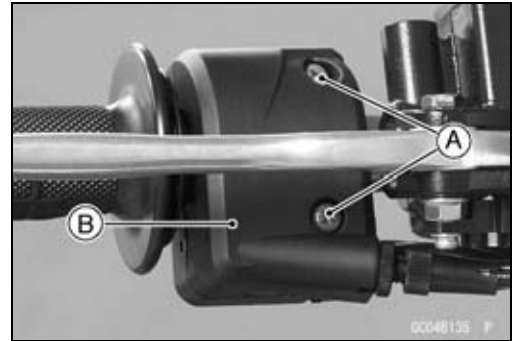

- Remove the throttle cable upper ends [A] from throttle grip [B].

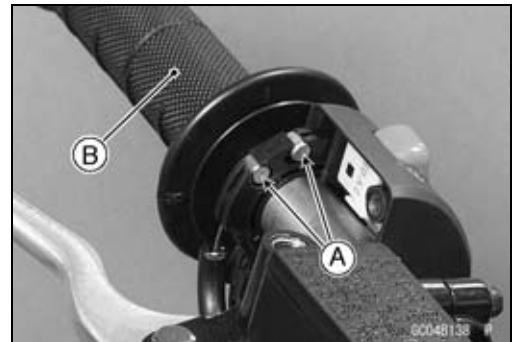

KLX250S Model

- Remove:
 - Bolts [A]
 - Throttle Pulley Cover [B]

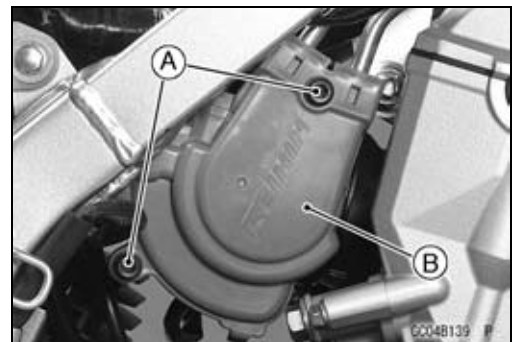

- Remove the throttle cable from holder [A] and remove the cable lower ends [B] from the throttle pulley.

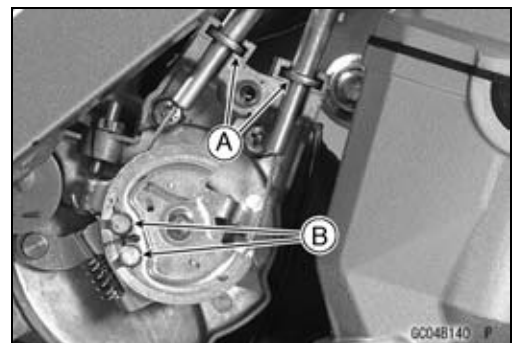

Throttle Grip and Cables

KLX250V Model

- Remove the clip [A].
- Remove the throttle cable from holder [B] and remove the cable lower ends [C] from the throttle pulley.
- Pull out the throttle cable from the frame.

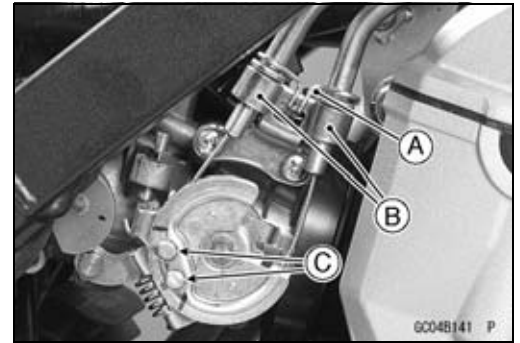

Throttle Cable Installation

- Lubricate the cable.
- Apply grease to the upper and lower ends of the cable.
- Install the lower ends of the cable to the throttle pulley.
- Install the cable in accordance with the Cable, Wire, and Hose Routing section in the Appendix chapter.
- Install the right switch housing after installing the upper ends of the cable in the throttle grip.
- After installation, adjust each cable properly (see Throttle Control System Inspection in the Periodic Maintenance chapter).

⚠ WARNING

Operation with incorrectly routed or improperly adjusted cables could result in an unsafe riding condition. Be sure the cables are routed correctly and properly adjusted.

Cable Lubrication

- Refer to the Chassis Parts Lubrication in the Periodic Maintenance chapter.

3-106 FUEL SYSTEM (DFI)

Throttle Body Assy

Idle Speed Inspection

- Refer to the Idle Speed Inspection in the Periodic Maintenance chapter.

Throttle Bore Cleaning

- Check the throttle bore for cleanliness as follows.
 - Remove the throttle body assy (see Throttle Body Assy Removal).
 - Check the throttle bore [A] at the main throttle valve for carbon deposits by opening the main throttle valve.
- ★ If any carbon accumulates, wipe the carbon off the throttle bore and the throttle valve, using a lint-free cloth penetrated with a high-flash point solvent.

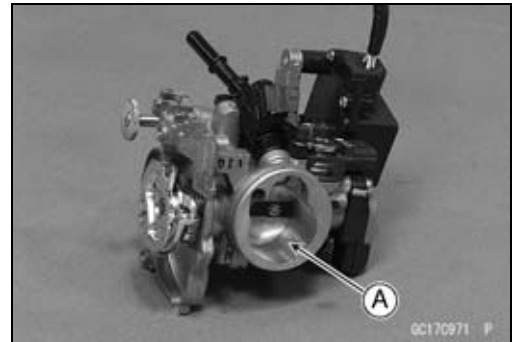

Throttle Body Assy Removal

⚠ WARNING

Gasoline is extremely flammable and can be explosive under certain conditions, creating the potential for serious burns. Make sure the area is well-ventilated and free from any source of flame or sparks; this includes any appliance with a pilot light. Do not smoke. Turn the ignition switch OFF. Be prepared for fuel spillage; any spilled fuel must be completely wiped up immediately.

NOTICE

Never drop the throttle body assy especially on a hard surface. Such a shock to the body assy can damage it.

- Remove:
 - Fuel Tank (see Fuel Tank Removal)
 - Throttle Cable Lower Ends (see Throttle Cable Removal)
 - Fuel Hose (see Fuel Injector Removal)
- Disconnect:
 - Fuel Injector Connector [A]
 - Subthrottle Valve Actuator Connector [B]
- Loosen the clamp screw [C].

- Disconnect:
 - Main Throttle Sensor Connector [A]
 - Subthrottle Sensor Connector [B]
- Loosen the clamp screw [C].

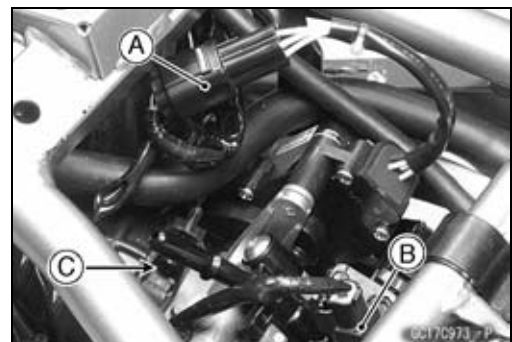

Throttle Body Assy

- Remove:
 - Bolts [A]
 - Vehicle-down Sensor (with Bracket) [B]
 - Subthrottle Sensor Connector [C]
- Remove the throttle body assy from air cleaner duct and remove from the throttle body holder.
- Remove the throttle body assy upward.

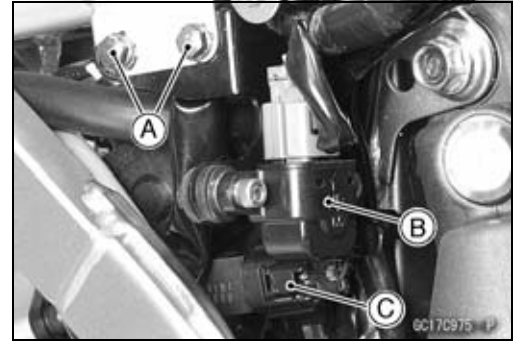

Throttle Body Assy Installation

- Install the throttle body assy so that fit the projection [B] on throttle body assy and groove [A] of the throttle body holder.

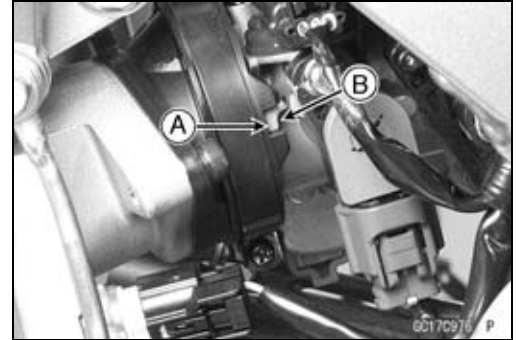

Throttle Body Assy Disassembly

NOTICE

Do not remove, disassemble or adjust the main throttle sensor, subthrottle sensor, subthrottle valve actuator, throttle link mechanism and throttle body assy, because they are adjust or set surely at the manufacturer. Adjustment of these parts could result in poor performance, requiring replacement of the throttle body assy.

- Remove the throttle body assy (see Throttle Body Assy Removal).
- Remove:
 - Screw [A]
 - Plate [B]
 - Inlet Air Pressure Sensor [C]
 - O-ring

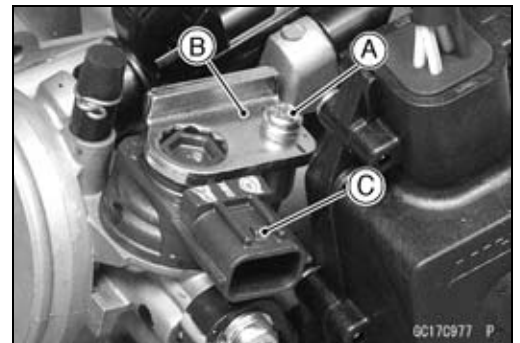

- Remove the screw [A] to pull out the injector from the throttle body assy together with the delivery pipe assy [B].

NOTE

○Do not damage the insertion portions of the injector when they are pulled out from the throttle body.

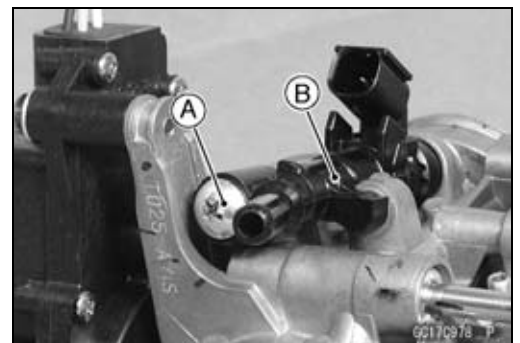

3-108 FUEL SYSTEM (DFI)

Throttle Body Assy

- Pull out the injector [A] from the delivery pipe [B].

NOTE

○Do not damage the insertion portions of the injector when they are pulled out from the delivery pipe.

NOTICE

Never drop the fuel injector especially on a hard surface. Such a shock to the injector can damage it.

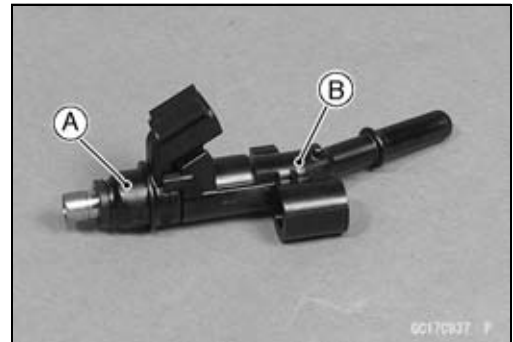

Throttle Body Assy Assembly

- Replace the O-ring [A] of fuel injector and dust seal [B] with a new one.

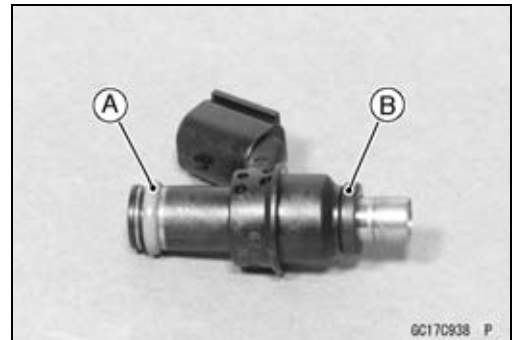

- Install the fuel injector [B] between the projections [A] on the delivery pipe.

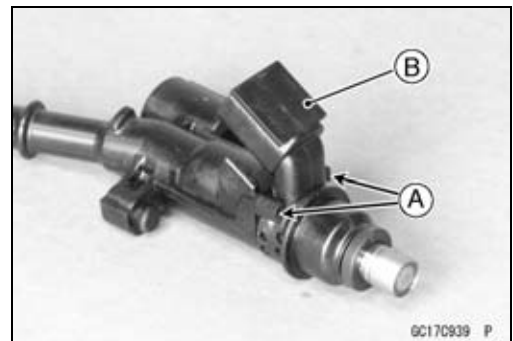

- Fit the projection [A] on the delivery pipe to the hollow [B] of the throttle body.
- Tighten the delivery pipe mounting screw.

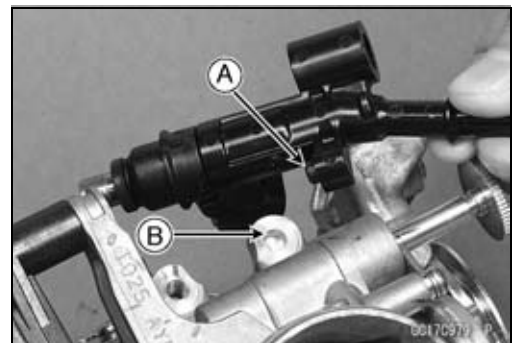

- Replace the O-ring [A] of inlet air pressure sensor with a new one.
- Install the inlet air pressure sensor to the throttle body assy.



Throttle Body Assy

- Install the plate so that fit the projection [A] on the plate and hollow [B] on the throttle body assy.
- Tighten the plate mounting screw securely.

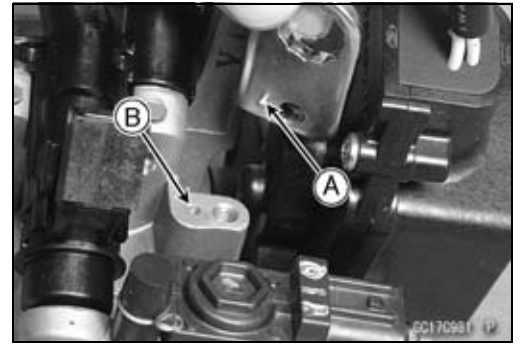

3-110 FUEL SYSTEM (DFI)

Air Cleaner

Air Cleaner Element Removal/Installation

- Refer to the Air Cleaner Element Replacement in the Periodic Maintenance chapter.

Air Cleaner Element Inspection

- Refer to the Air Cleaner Element Cleaning in the Periodic Maintenance chapter.

Air Cleaner Housing Removal

- Remove:
 - Right and Left Side Covers (see Side Cover Removal in the Frame chapter)
 - Rear Fender Front (see Rear Fender Removal in the Frame chapter)
 - Rear Fender Flap Front (see Rear Fender Flap Front Removal in the Frame chapter)
 - ECU (see ECU Removal)
 - Bolt [A]
- Remove:
 - Breather Hose [A]
- Loosen the muffler clamp bolt [B], and move the clamp forward.
- Loosen the air cleaner duct clamp screw [C].
- Pull the air cleaner drain hose [D] out of the air cleaner housing.
- Remove:
 - Inlet Air Temperature Sensor Connector [A]
 - Air Switching Valve Hose [B]
 - Rear Shock Absorber (see Rear Shock Absorber Removal in the Suspension chapter)
- Remove the air cleaner housing [A] from the left side of the motorcycle.

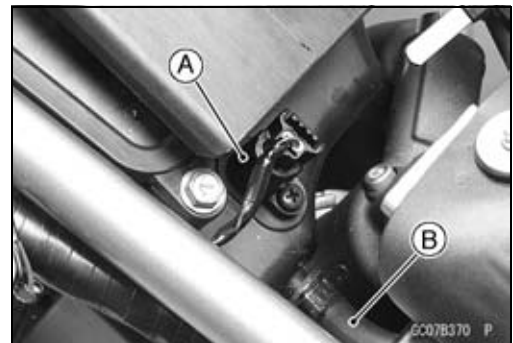
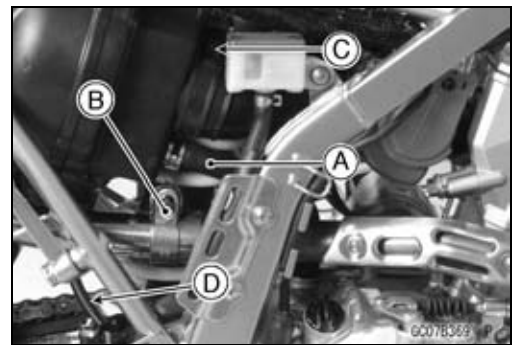
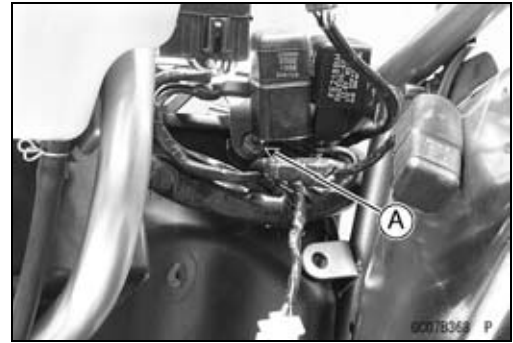

Air Cleaner

Air Cleaner Housing Installation

- Fit the projection [A] of the air cleaner housing into the groove [B] of the air cleaner duct.
- Tighten the clamp screw securely.
- Run the removed hoses properly (see Cable, Wire and Hose Routing in the Appendix chapter).

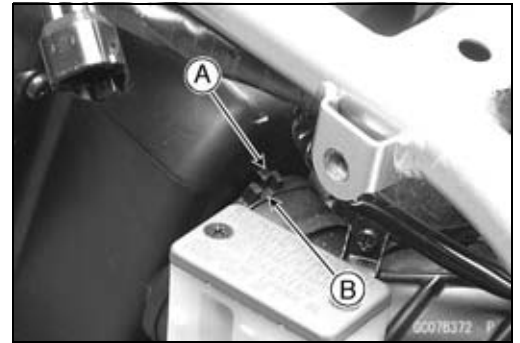

3-112 FUEL SYSTEM (DFI)

Fuel Tank

Fuel Tank Removal

⚠ WARNING

Gasoline is extremely flammable and can be explosive under certain conditions, creating the potential for serious burns. Make sure the area is well-ventilated and free from any source of flame or sparks; this includes any appliance with a pilot light. Do not smoke. Turn the ignition switch OFF. Disconnect the battery (–) terminal. To avoid fuel spills, draw it from the tank when the engine is cold. Be prepared for fuel spillage; any spilled fuel must be completely wiped up immediately.

- Turn the ignition switch OFF.
- Wait until the engine cools down.
- Disconnect the battery (–) terminal (see Battery Removal in the Electrical System chapter).
- Remove:
 - Radiator Shroud (see Radiator Shroud Removal in the Electrical System chapter)
 - Seat (see Seat Removal in the Frame chapter)
 - Fuel Tank Bolts [A]
- Draw the fuel out from the fuel tank with a commercially available pump [A].
- Use a soft plastic hose [B] as a pump inlet hose in order to insert the hose smoothly.
- Put the hose through the fill opening [C] into the tank and draw the fuel out.

⚠ WARNING

Spilled fuel is flammable and can be explosive under certain conditions. The fuel can not be removed completely from the fuel tank. Be careful for remained fuel spillage.

- Remove:
 - Clamp [A]
- Disconnect:
 - Fuel Pump Lead Connector [B]

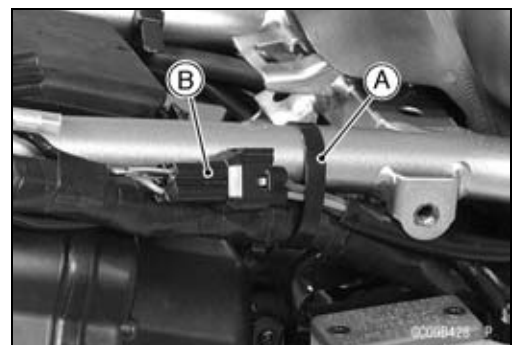
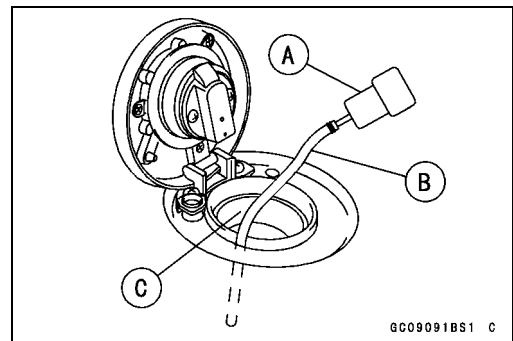
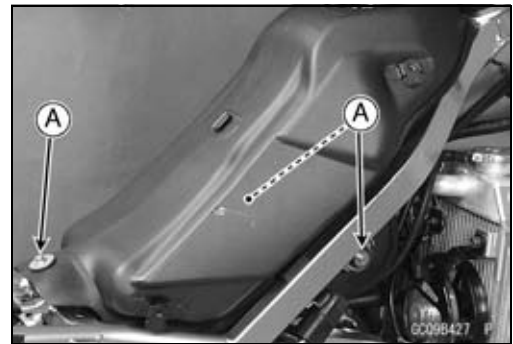

Fuel Tank

- Be sure to place a piece of cloth [B] around the fuel outlet hose joint [A].
- Remove:
 - Breather Hose [C]
 - Drain Hose [D]
- Insert a minus screw driver [E] into the slit on the joint lock.
- Turn the driver to disconnect the joint lock.

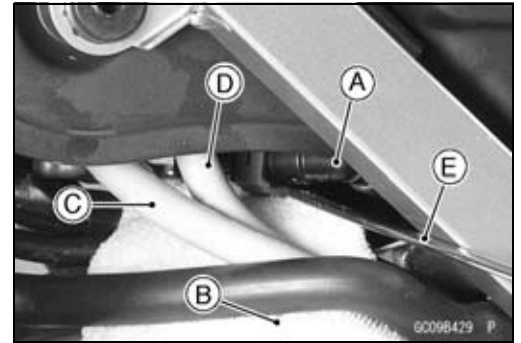

- Pull [B] the fuel outlet hose joint [A] out of the fuel outlet pipe.

⚠ WARNING

Fuel is flammable and explosive under certain conditions and can cause severe burns. Be prepared for fuel spillage; any spilled fuel must be completely wiped up immediately. When the fuel hose is disconnected, fuel spills out from the hose and the pipe because of residual pressure. Cover the hose connection with a piece of clean cloth to prevent fuel spillage.

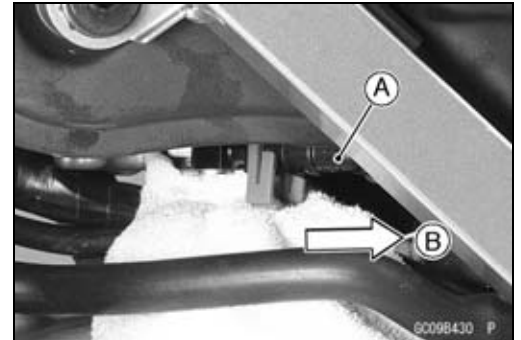

- Close the fuel tank cap.
- Remove the fuel tank, and place it on a flat surface.
- Do not apply the load to the fuel inlet pipe of the fuel pump.

⚠ WARNING

Gasoline is extremely flammable and can be explosive under certain conditions, creating the potential for serious burns. Store the fuel tank in an area which is well-ventilated and free from any source of flame or sparks. Do not smoke in this area. Place the fuel tank on a flat surface and plug the fuel pipes to prevent fuel leakage.

Fuel Tank Installation

- Note the above WARNING (see Fuel Tank Removal).
- Route the hoses correctly (see Cable, Wire, and Hose Routing section in the Appendix chapter).
- Check that the dampers [A] are in place on the frame.
- ★ If the dampers are damaged or deteriorated, replace it.



3-114 FUEL SYSTEM (DFI)

Fuel Tank

- Check the trim [A] is in place on the fuel tank.
- ★ If the trim is damaged or deteriorated, replace it with a new one.

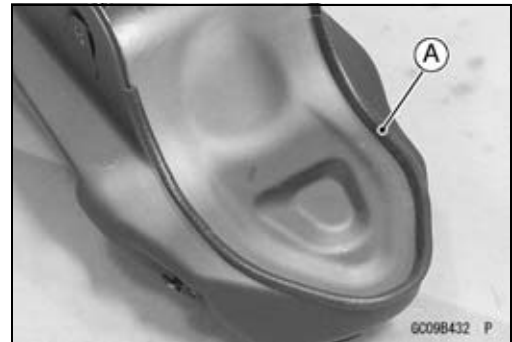

- Insert the fuel outlet hose joint [A] straight onto the fuel outlet pipe until the hose joint clicks.
- Push the joint lock [B] until the hose joint clicks.

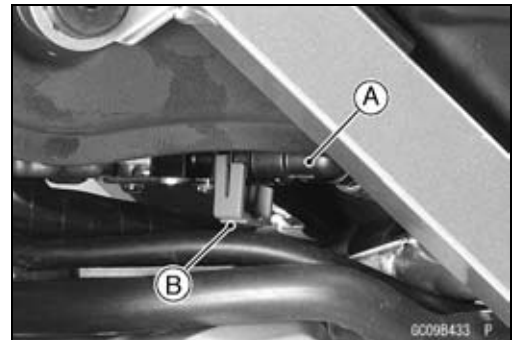

- Push and pull [B] the hose joint [A] back and forth more than two times, and make sure it is locked and does not come off.

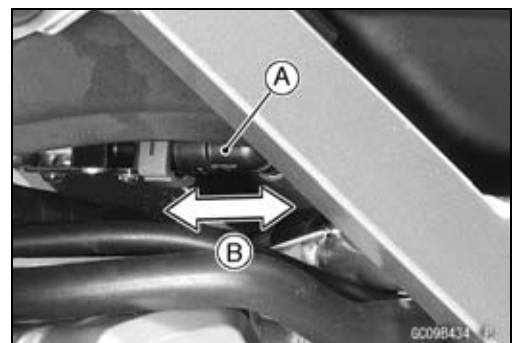

⚠ WARNING

Leaking fuel can cause a fire or explosion resulting in serious burns. Make sure the hose joint is installed correctly on the delivery pipe.

- ★ If it comes off, reinstall the hose joint.
- Install the breather hose and drain hose.
- Tighten the fuel tank bolt.
- Connect the fuel pump lead connector and battery (-) terminal (see the Battery Installation in the Electrical System chapter).

Fuel Tank Inspection

- Open the tank cap.
- Visually inspect the gasket [A] on the tank cap for any damage.
- ★ If gasket is damaged, replace the tank cap with a new one.
- Check to see if the water drain pipe [B] and fuel breather pipe [C] in the tank are not clogged. Check the tank cap breather also.
- ★ If they are clogged, remove the tank and drain it, and then blow the breather free with compressed air.

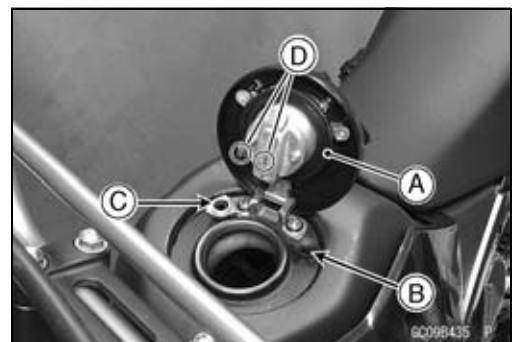

NOTICE

Do not apply compressed air to the air vent holes [D] in the tank cap. This could cause damage and clogging of the labyrinth in the cap.

Fuel Tank

Fuel Tank Cleaning** WARNING**

Gasoline and low-flash point solvents can be flammable and/or explosive and cause severe burns. Clean the tank in a well-ventilated area, and take care that there are no sparks or flame anywhere near the working area. Do not use gasoline or low-flash point solvents to clean the tank.

- Remove:
 - Fuel Tank (see Fuel Tank Removal)
 - Fuel Inlet Hose (see Fuel Hose Replacement in the Periodic Maintenance chapter)
 - Fuel Pump (see Fuel Pump Removal)
- Pour some high-flash point solvent into the fuel tank and shake the tank to remove dirt and fuel deposits.
- Draw the solvent out of the fuel tank.
- Dry the tank with compressed air.
- Install:
 - Fuel Pump (see Fuel Pump Installation)
 - Fuel Inlet Hose (see Fuel Hose Replacement in the Periodic Maintenance chapter)
 - Fuel Tank (see Fuel Tank Installation)

3-116 FUEL SYSTEM (DFI)

Evaporative Emission Control System (SEA and TH Models)

The Evaporative Emission Control System routes fuel vapors from the fuel system into the running engine or stores the vapors in a canister when the engine is stopped. Although no adjustments are required, a thorough visual inspection must be made at the intervals specified by the Periodic Maintenance Chart.

Parts Removal/Installation

⚠ WARNING

Gasoline is extremely flammable and can be explosive under certain conditions. Turn the ignition switch OFF. Do not smoke. Make sure the area is well-ventilated and free from any source of flame or sparks; this includes any appliance with a pilot light.

NOTICE

If gasoline, solvent, water or any other liquid enters the canister, the canister's vapor absorbing capacity is greatly reduced. If the canister does become contaminated, replace it with a new one.

- To prevent the gasoline from flowing into or out of the canister, hold the separator perpendicular to the ground.
- Connect the hoses according to the see Cable, Wire, and Hose Routing section in the Appendix chapter. Make sure they do not get pinched or kinked.

Hose Inspection

- Refer to the Evaporative Emission Control System Inspection in the Periodic Maintenance chapter.

Separator Inspection

- Refer to the Evaporative Emission Control System Inspection in the Periodic Maintenance chapter.

Evaporative Emission Control System (SEA and TH Models)

Separator Operation Test

⚠ WARNING

Gasoline is extremely flammable and can be explosive under certain conditions. Turn the ignition switch OFF. Do not smoke. Make sure the area is well-ventilated and free from any source of flame or sparks; this includes any appliance with a pilot light.

- Connect the hoses to the separator, and install the separator on the motorcycle.
- Disconnect the breather hose from the separator, and inject about 20 mL (0.68 US oz.) of gasoline [A] into the separator [B] through the hose fitting.
- Disconnect the fuel return hose [C] from the fuel tank [D].
- Run the open end of the return hose into the container and hold it level with the tank top [E].
- Start the engine, and let it idle.
- ★ If the gasoline in the separator comes out of the hose, the separator works well. If it does not, replace the separator with a new one.

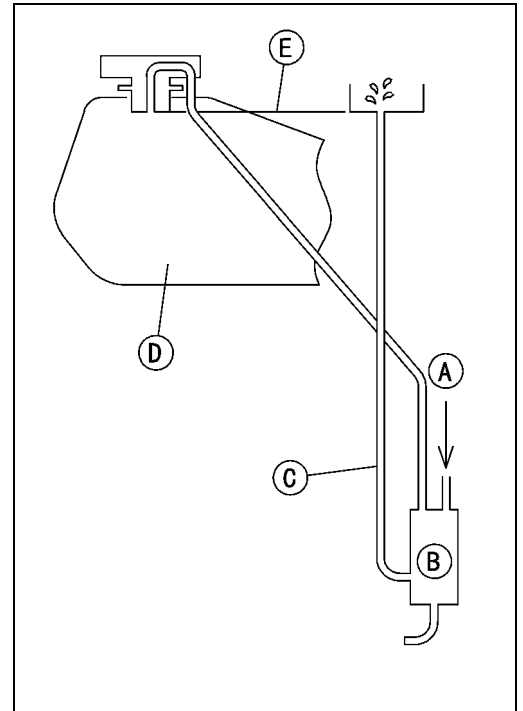

Canister Inspection

- Refer to the Evaporative Emission Control System Inspection in the Periodic Maintenance chapter.

Cooling System

Table of Contents

- Exploded View 4-2
- Coolant Flow Chart 4-4
- Specifications 4-6
- Special Tools 4-7
- Coolant 4-8
 - Coolant Deterioration Inspection 4-8
 - Coolant Level Inspection 4-8
 - Coolant Draining 4-8
 - Coolant Filling 4-8
 - Pressure Testing 4-8
 - Cooling System Flushing 4-9
- Water Pump 4-10
 - Water Pump Removal 4-10
 - Water Pump Installation 4-10
 - Water Pump Inspection 4-11
 - Mechanical Seal Replacement 4-11
- Radiators 4-14
 - Radiator Removal 4-14
 - Radiator Installation 4-15
 - Radiator Inspection 4-15
 - Radiator Cap Inspection 4-16
 - Radiator Filler Neck Inspection 4-16
- Thermostat 4-17
 - Thermostat Removal 4-17
 - Thermostat Installation 4-17
 - Thermostat Inspection 4-17
- Hose 4-18
 - Hose Installation 4-18
 - Hose Inspection 4-18
- Water Temperature Sensor 4-19
 - Water Temperature Sensor Removal/Installation 4-19
 - Water Temperature Sensor Inspection 4-19

4-2 COOLING SYSTEM

Exploded View

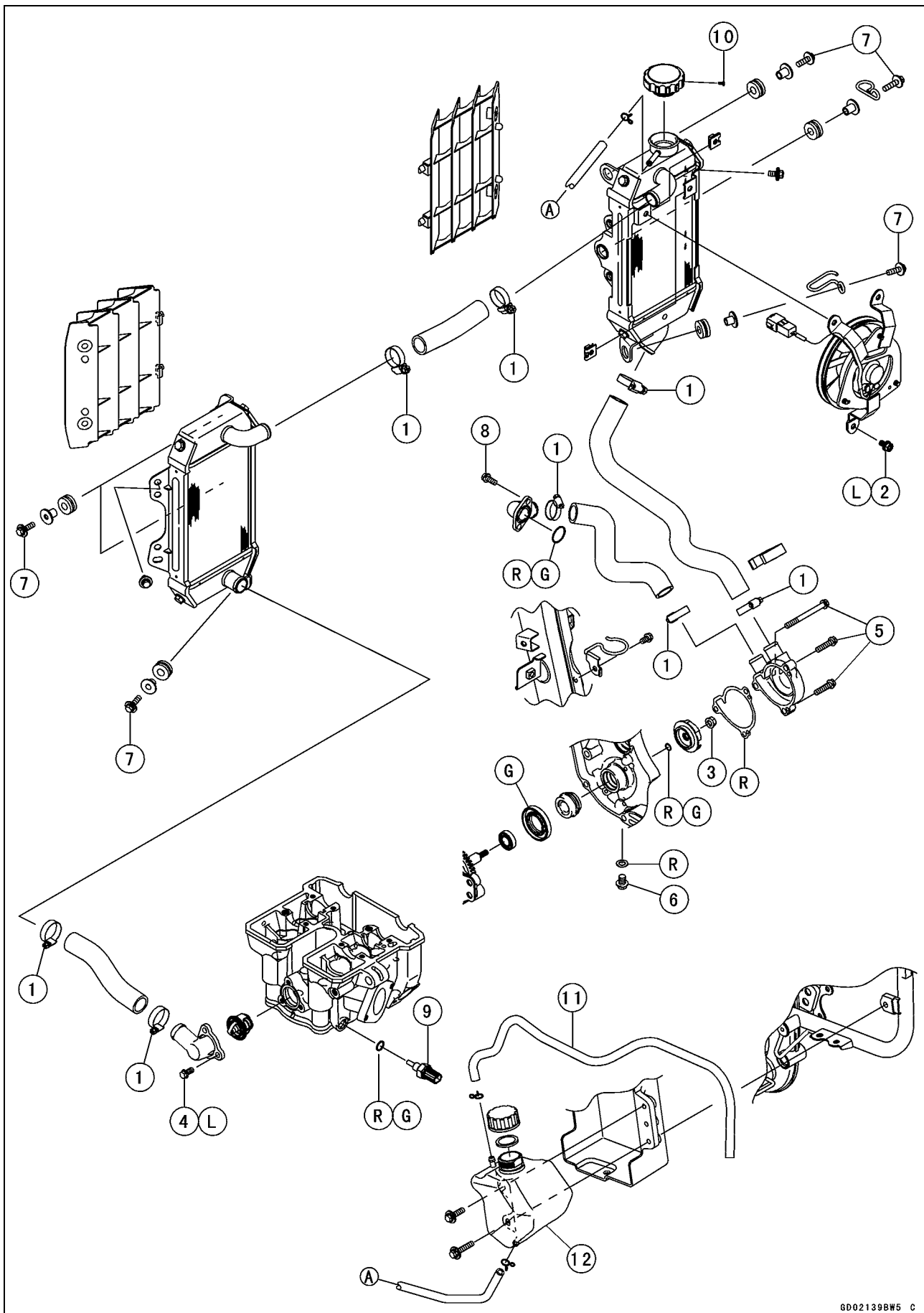

Exploded View

No.	Fastener	Torque			Remarks
		N·m	kgf·m	ft·lb	
1	Radiator Hose Clamp Screws	1.5	0.15	13 in·lb	
2	Radiator Fan Bolts	7.0	0.71	62 in·lb	L
3	Water Pump Impeller Nut	7.8	0.80	69 in·lb	
4	Thermostat Housing Bolts	9.8	1.0	87 in·lb	L
5	Water Pump Cover Bolts	9.8	1.0	87 in·lb	
6	Coolant Drain Plug	25	2.5	18	
7	Radiator Bolts	6.9	0.70	61 in·lb	
8	Water Hose Fitting Bolts	10	1.0	89 in·lb	
9	Water Temperature Sensor	12	1.2	106 in·lb	
10	Radiator Cap Stop Screw	2.5	0.25	22 in·lb	

11. Coolant Overflow Hose

12. Reserve Tank

G: Apply grease.

L: Apply a non-permanent locking agent.

R: Replacement Parts

4-4 COOLING SYSTEM

Coolant Flow Chart

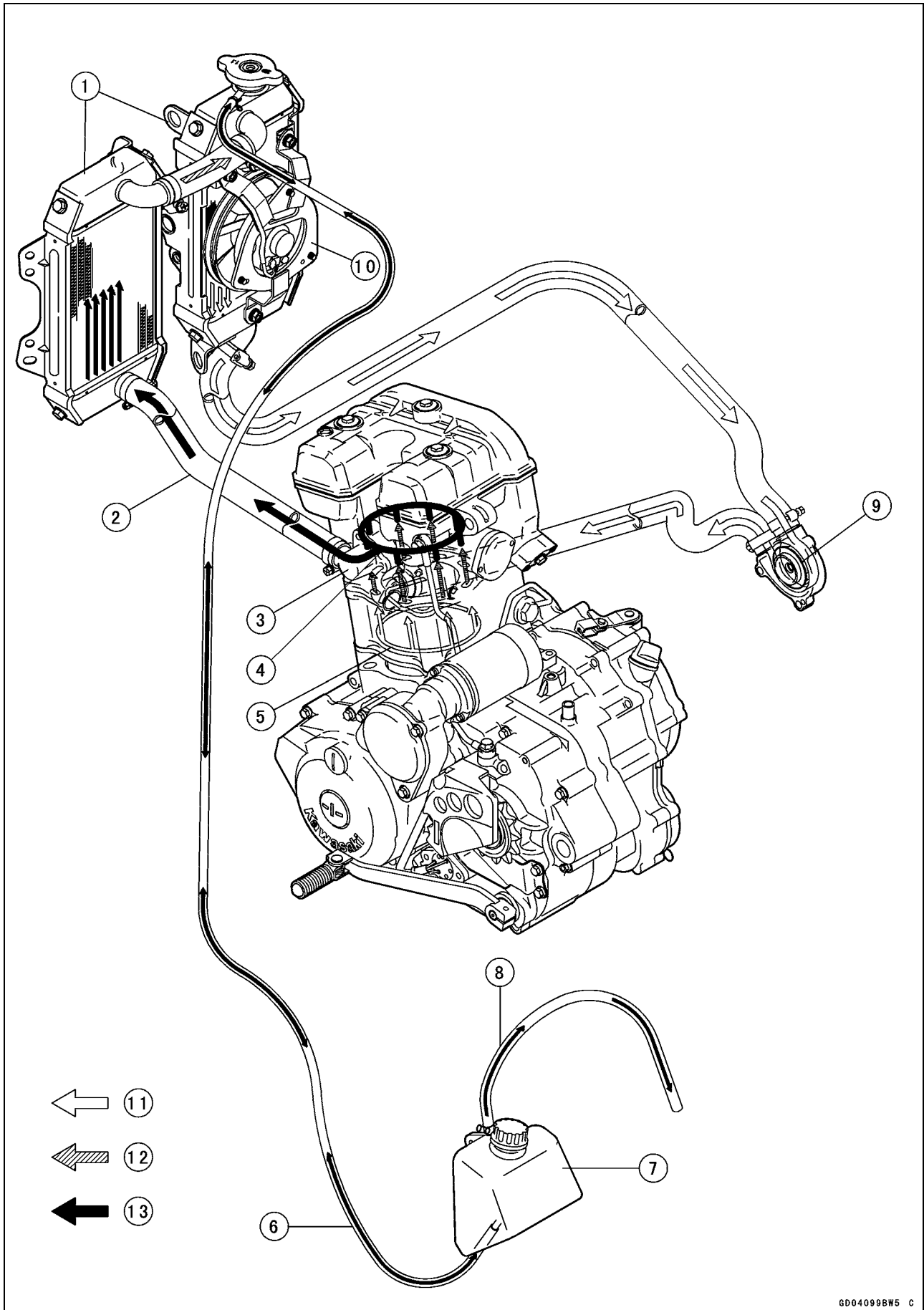

Coolant Flow Chart

1. Radiators
2. Water Hose
3. Thermostat
4. Cylinder Head Jacket
5. Cylinder Jacket
6. Reserve Tank Hose
7. Reserve Tank
8. Reserve Tank Over Flow Hose
9. Water Pump
10. Radiator Fan
11. Cold Coolant
12. Warm Coolant
13. Hot Coolant

Permanent type antifreeze (for aluminum radiators) is used as a coolant to protect the cooling system from rust and corrosion. When the engine starts, the water pump (coupled with the oil pump) turns and the coolant circulates.

The thermostat is a wax pellet type which opens or closes as coolant temperature changes. The thermostat continuously changes its valve opening to keep the coolant temperature at the proper level. When coolant temperature is below 69.5 ~ 72.5°C (157 ~ 163°F), the thermostat closes so that the coolant flow is restricted through the air bleeder hole, causing the engine to warm up more quickly. When coolant temperature is more than 69.5 ~ 72.5 °C (157 ~ 163°F), the thermostat opens and the coolant flows.

When the coolant temperature is more than 98°C (208°F), the radiator fan relay ON to operate the radiator fan. The radiator fan draws air through the radiator core when there is not sufficient air flow such as at low speeds. This increases up the cooling action of the radiator. When the temperature is below 95°C (203°F), the fan relay OFF and the radiator fan stops.

In this way, this system controls the engine temperature within narrow limits where the engine operates most efficiently even if the engine load varies.

The system is pressurized by the radiator cap to suppress boiling and the resultant air bubbles which can cause engine overheating. As the engine warms up, the coolant in the radiator and the water jacket expands. The excess coolant flows through the radiator cap and hose to the reserve tank to be stored there temporarily. Conversely, as the engine cools down, the coolant in the radiator and the water jacket contracts, and the stored coolant flows back to the radiator from the reserve tank.

The radiator cap has two functions: One is a pressure valve which holds the pressure in the system when the engine is running. When the pressure exceeds 93 ~ 123 kPa (0.95 ~ 1.25 kgf/cm², 13 ~ 17.8 psi), the pressure valve opens and releases the pressure to the reserve tank. As soon as pressure escapes, the valve closes, and keeps the pressure at 93 ~ 123 kPa (0.95 ~ 1.25 kgf/cm², 13 ~ 17.8 psi). When the engine cools down, another small valve (vacuum valve) in the cap opens. As the coolant cools, the coolant contracts to form a vacuum in the system. The vacuum valve opens and allows the coolant from the reserve tank to enter the radiator.

4-6 COOLING SYSTEM

Specifications

Fastener	Standard
Coolant Type (Recommended) Color Mixed Ratio Freezing Point Total Amount	Permanent Type of Antifreeze (Ethylene glycol plus corrosion and rust inhibitor chemicals for aluminum engines and radiators) Green Soft water 50% and coolant 50% -35°C (-31°F) 1.3 L (1.4 US qt) (reserve tank full level including radiator and engine)
Radiator Cap Relief Pressure	93 ~ 123 kPa (0.95 ~ 1.25 kgf/cm ² , 13.5 ~ 17.8 psi)
Thermostat Valve Opening Temperature Valve Full Opening Lift	69.5 ~ 72.5 °C (157 ~ 163 °F) 3 mm (0.12 in) or more at 85 °C (185 °F)

Special Tools

**Bearing Driver Set:
57001-1129**

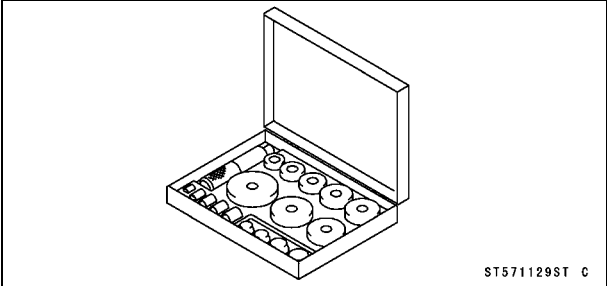

**Bearing Remover Head $\phi 10 \times \phi 12$:
57001-1266**

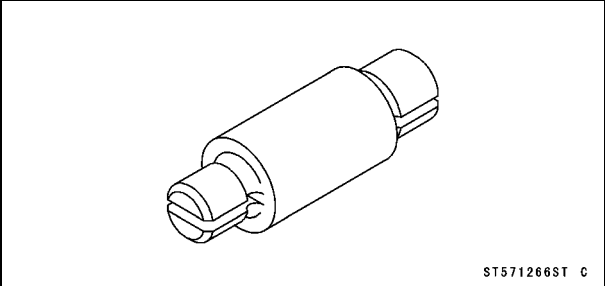

**Bearing Remover Shaft:
57001-1265**

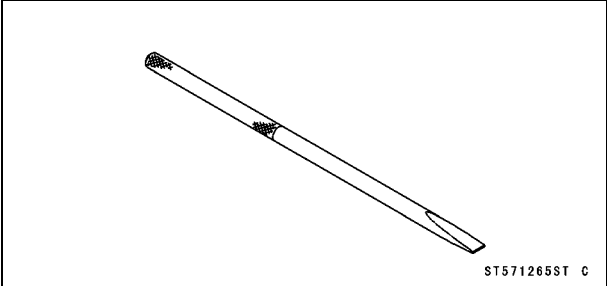

4-8 COOLING SYSTEM

Coolant

Coolant Deterioration Inspection

- Remove the left side cover (see Side Cover Removal in the Frame chapter).
- Visually inspect the coolant in the reserve tank [A].
- ★ If whitish cotton-like wafts are observed, aluminum parts in the cooling system are corroded. If the coolant is brown, iron parts are rusting. In either case, flush the cooling system.
- ★ If the coolant gives off an abnormal smell, check for a cooling system leak. It may be caused by exhaust gas leaking into the cooling system.



Coolant Level Inspection

- Refer to the Coolant Level Inspection in the Periodic Maintenance chapter.

Coolant Draining

- Refer to Coolant Change in the Periodic Maintenance chapter.

Coolant Filling

- Refer to Coolant Change in the Periodic Maintenance chapter.

Pressure Testing

- Remove the radiator cap (see Coolant Change in the Periodic Maintenance chapter), and install a cooling system pressure tester [A] on the filler neck [B].

NOTE

○ *Wet the cap sealing surfaces with water or coolant to prevent pressure leaks.*

- Build up pressure in the system carefully until the pressure reaches 123 kPa (1.25 kgf/cm², 17.8 psi).

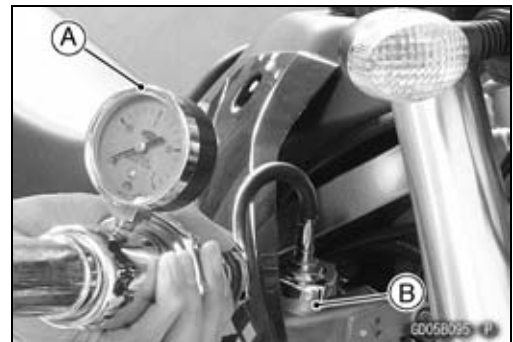

NOTICE

During pressure testing, do not exceed the pressure for which the system is designed. The maximum pressure is 123 kPa (1.25 kgf/cm², 17.8 psi).

- Watch the gauge for at least 6 seconds.
- ★ If the pressure holds steady, the system is all right.
- ★ If the pressure drops and no external source is found, check for internal leaks. Droplets in the engine oil indicate internal leakage. Check the cylinder head gasket and the water pump.
- Remove the pressure tester, replenish the coolant, and install the radiator cap.

Coolant

Cooling System Flushing

Over a period of time, the cooling system accumulates rust, scale, and lime in the water jacket and radiator. When this accumulation is suspected or observed, flush the cooling system. If this accumulation is not removed, it will clog up the water passage and considerably reduce the efficiency of the cooling system.

- Drain the coolant (see Coolant Change in the Periodic Maintenance chapter).
- Fill the cooling system with fresh water mixed with a flushing compound.

NOTICE

Avoid the use of a flushing compound which is harmful to the aluminum engine and radiator. Carefully follow the instructions supplied by the manufacture of the cleaning product.

- Warm up the engine, and run it at normal operating temperature for about 10 minutes.
- Stop the engine, and drain the cooling system.
- Fill the system with fresh water.
- Warm up the engine and drain the system.
- Repeat the previous two steps once more.
- Fill the system with a permanent type coolant and bleed the air from the system (see Coolant Change in the Periodic Maintenance chapter).

4-10 COOLING SYSTEM

Water Pump

Water Pump Removal

- Drain the coolant (see Coolant Change in the Periodic Maintenance chapter).
- Loosen the clamp screws [A] fully.
- Disconnect the radiator hose [B] from the water pump cover [C].
- Remove:
 - Water Pump Cover Bolts [D]
 - Water Pump Cover

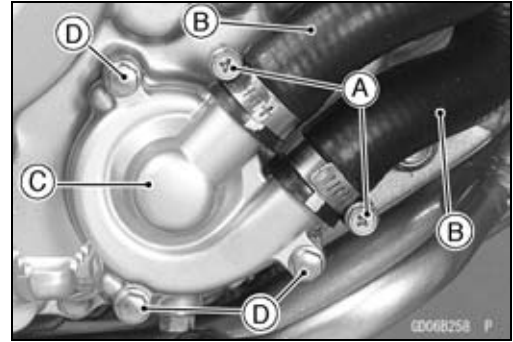

- Remove:
 - Impeller Nut [A]
 - Impeller [B]

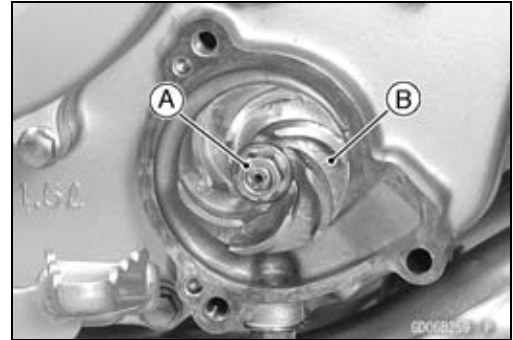

Water Pump Installation

- Install the new O-ring [A] on the water pump shaft.
- Install the impeller on the water pump shaft, and tighten the impeller nut.

Torque - Water Pump Impeller Nut: 7.8 N·m (0.80 kgf·m, 69 in·lb)

NOTICE

In installing the impeller, take care so as not to damage the O-ring with threads of the water pump shaft.



- Be sure that the dowel pins [A] are in position.
- Replace the pump cover gasket [B] with a new one, and install the water pump cover.

Torque - Water Pump Cover Bolts: 9.8 N·m (1.0 kgf·m, 87 in·lb)

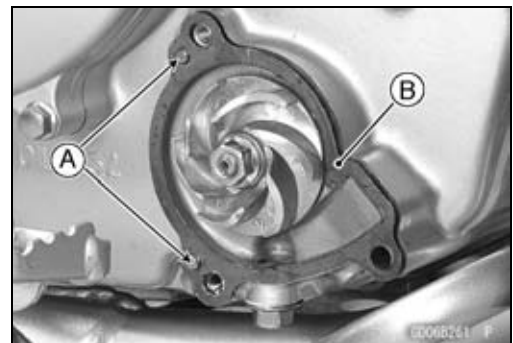

Water Pump

Water Pump Inspection

- Check the drainage outlet passage [A] at the bottom of the right engine cover for coolant leakage.
- ★ If the mechanical seal is damaged, the coolant leaks through the seal and drains through the passage. Replace the mechanical seal with a new one.



- Visually check the impeller [A].
- ★ If the surface is corroded, or if the blades [B] are damaged, replace the impeller.

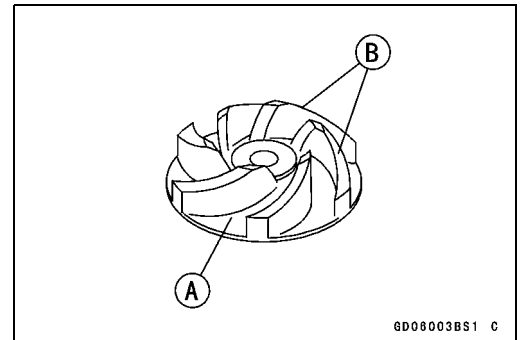

Mechanical Seal Replacement

- Remove the water pump impeller (see Water Pump Removal).
- Pry the mechanical seal flange off with a thin blade screw driver [A].
- Pull the mechanical seal out of the right crankcase with needle nose pliers, and replace it with a new one.

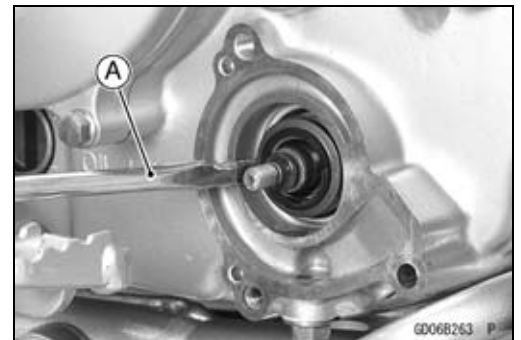

NOTICE

Take care so as not to damage inner seal surfaces of the water pump shaft and the right engine cover.

NOTE

○ Since the mechanical seal replaced has an adhesive coated body, do not apply a liquid gasket to the exterior surface of the body.

- Press [A] the mechanical seal [B] by using a suitable tool [C] (inside diameter: 28 mm, outside diameter: 32 mm) and a bearing driver [D] until its flange touches the step [E] as shown in the figure.

Special Tool - Bearing Driver Set: 57001-1129

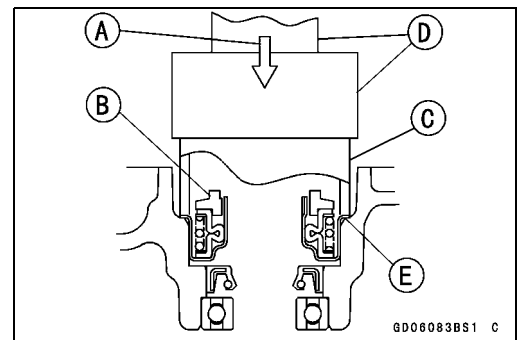

4-12 COOLING SYSTEM

Water Pump

Ball Bearing, Oil Seal Replacement

★Although a small quantity of coolant may leak from the mechanical seal until its sealing surface settles, if the leakage still continues, the damages on the seal and the ball bearing are considered. Replace the mechanical seal, ball bearing and oil seal.

- Remove the right engine cover (see Right Engine Cover Removal in the Clutch chapter).
- Take the bearing [A] out of the right engine cover, using the bearing remover.

Special Tool - Bearing Remover Shaft: 57001-1265 [B]

Bearing Remover Head, $\phi 10 \times \phi 12$: 57001-1266 [C]

- Press out the mechanical seal [A] and oil seal [B] from the inside of the right engine cover with the bearing driver set [C].

Special Tool - Bearing Driver Set: 57001-1129

○Be sure to replace the mechanical seal, oil seal, O-ring, and ball bearings with new ones because these parts will be damaged by removal.

- Apply plenty of high temperature grease to the oil seal lips.
- Apply oil to the outer circumference of the oil seal.
- Press the oil seal [A] into the hole from the outside of the right engine cover with the bearing driver set so that the spring side of the seal lips is toward the inside of the right engine cover.

Special Tool - Bearing Driver Set: 57001-1129

- Press in the oil seal so that the seal end is flush with the step [B] of the hole as shown.
- Use the bearing driver which has a larger diameter than the oil seal.
- Press in the ball bearing [C] with its manufacturer's mark facing out until it bottoms out.

- Press [A] the mechanical seal [B] by using a suitable tool [C] (inside diameter: 28 mm, outside diameter: 32 mm) and a bearing driver [D] until its flange touches the step [E] as shown in the figure.

- Install the water pump shaft from the inside of the right engine cover.

Special Tool - Bearing Driver Set: 57001-1129

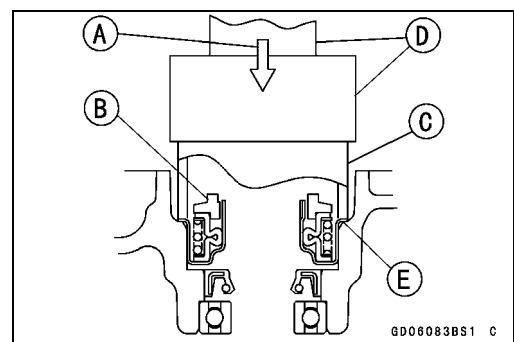
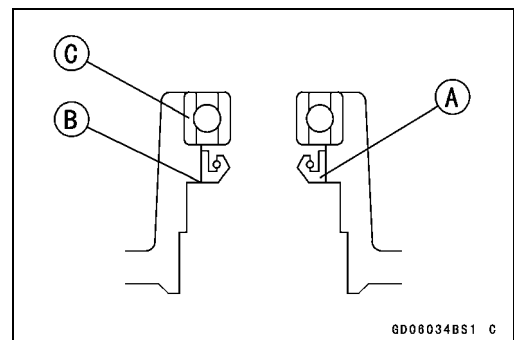
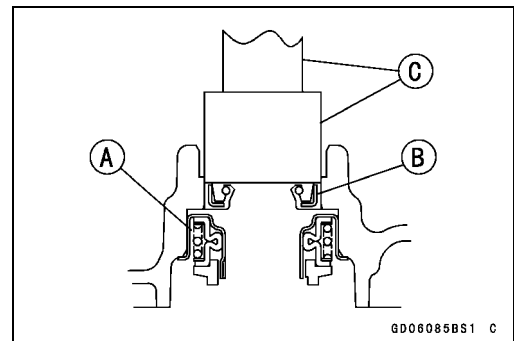
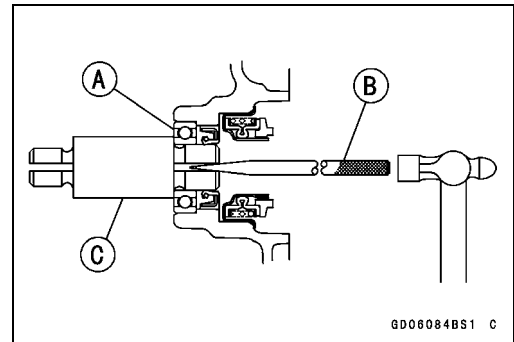

Water Pump

- Clean both sliding surfaces of a new mechanical seal with a high-flash point solvent (e.g. ethyl alcohol), and apply a little coolant to the sliding surface to give the mechanical seal initial lubrication.
- Apply coolant to the surfaces of the rubber seal [A] and sealing seat [B], and press the rubber seal and sealing seat into the impeller by hand until the seat bottoms out.
- Install the new O-ring on the water pump shaft.
- Tighten:
Torque - Water Pump Impeller Nut: 7.8 N·m (0.80 kgf·m, 69 in·lb)

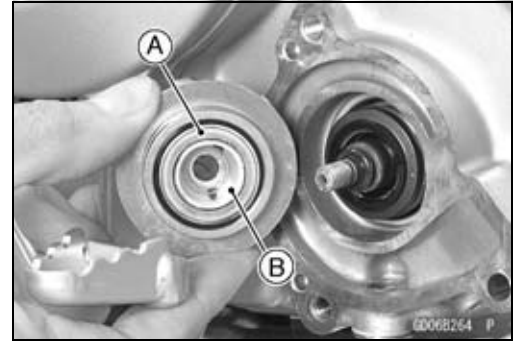

4-14 COOLING SYSTEM

Radiators

Radiator Removal

- Drain the coolant (see Coolant Change in the Periodic Maintenance chapter).
- Remove:
 - Radiator Shrouds (see Radiator Shroud Removal in the Frame chapter)
 - Fuel Tank (see Fuel Tank Removal in the Fuel System (DFI) chapter)
 - Radiator Fan Connector [A] (disconnect)
- Loosen the radiator hose clamp screw [B] fully.
- Loosen the radiator hose clamp screw [A] fully.
- Disconnect:
 - Radiator Hose [B]
 - Reserve Tank Hose [C]
- Remove:
 - Right Screen Mounting Bolt [D]
 - Right Screen [E]
- Remove:
 - Radiator Mounting Bolts [A]
 - Right Radiator [B]
- Loosen the radiator hose clamp screw [A] fully.
- Remove:
 - Left Screen Mounting Bolt [B]
 - Left Screen [C]
- Remove:
 - Radiator Mounting Bolts [A]
 - Left Radiator [B]

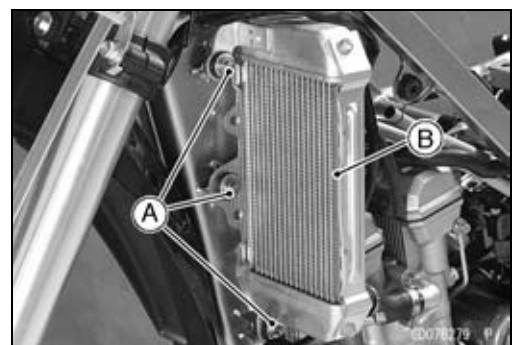
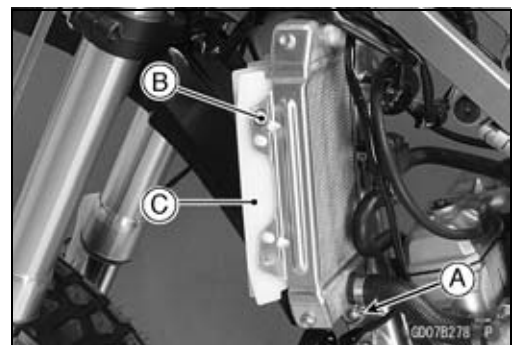
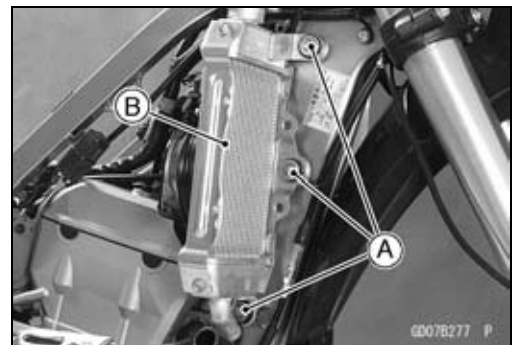
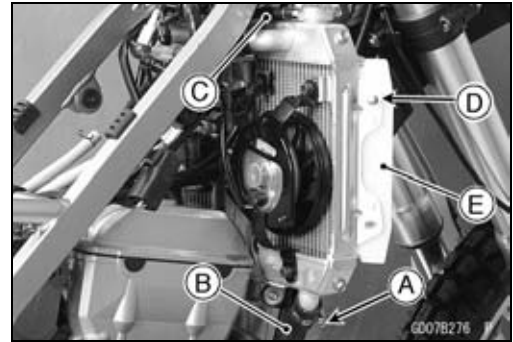
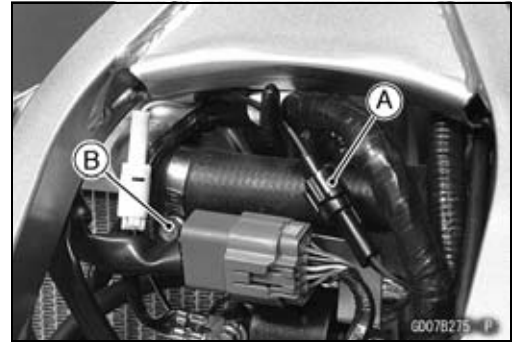

Radiators

- Remove:
Radiator Fan Bolts [A]
Radiator Fan [B]

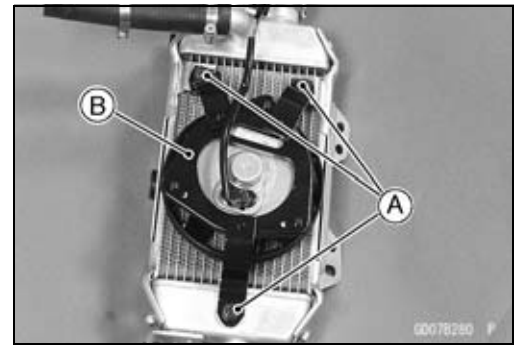

Radiator Installation

- Hold the clutch cable with the clamps [A].
- Run the radiator hose and reserve tank hose correctly (see Cable, Wire and Hose Routing in the Appendix chapter).

Torque - Radiator Bolts: 6.9 N·m (0.70 kgf·m, 61 in·lb)



Radiator Inspection

- Check for radiator core clogging and bent fins [A].
- ★ Correct bent fins, if any, with a flat blade screw driver.

NOTICE

Do not tear the radiator tubes while straightening the fins.

- ★ If the radiator core are blocked more than 20% by unremovable obstructions or irreparably deformed fins, replace the radiator with a new one.

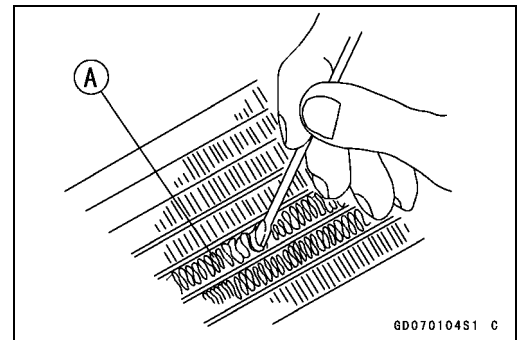

NOTICE

When cleaning the radiator with a steam cleaner, be careful of the followings:

1. Keep the steam gun [A] away more than 50 cm [B] from the radiator core.
2. Hold the steam gun perpendicular to the core surface.
3. When you move the nozzle in cleaning, move it parallel to the fins [C]. (never move it at right angles to the fins)

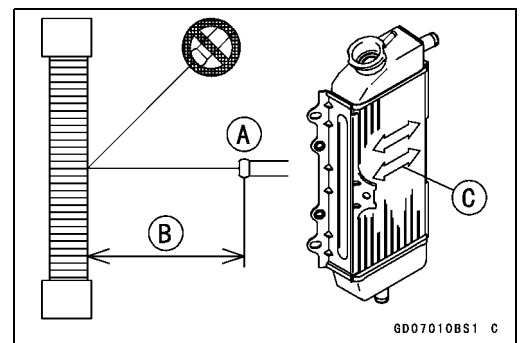

4-16 COOLING SYSTEM

Radiators

Radiator Cap Inspection

- Remove the radiator cap.
- Visually inspect the condition of the bottom [A] and top [B] of the valve seals and valve spring [C].
- ★ If they show any damage, replace the cap with a new one.

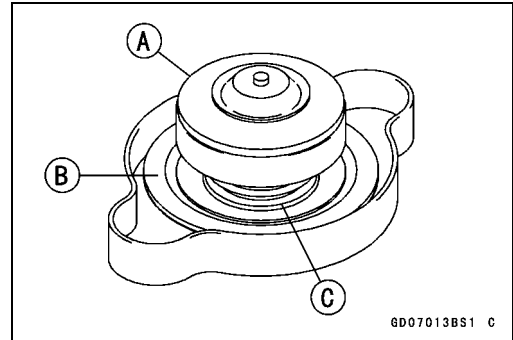

- Install the cap [A] on a pressure tester [B], and check the relief pressure.
- Apply water or coolant to both seal surfaces of the cap so that pressure is not released.
- Watching the pressure gauge, pump the pressure tester to build up the pressure. The relief valve must open within the specified range and the gauge hand must remain within the same range at least 6 seconds.

Relief Pressure

Standard: 93 ~ 123 kPa (0.95 ~ 1.25 kgf/cm², 13.5 ~ 17.8 psi)

- ★ If the cap cannot hold the pressure within the specified range for 6 seconds, or if the relief pressure is too high or too low, replace the cap with a new one.

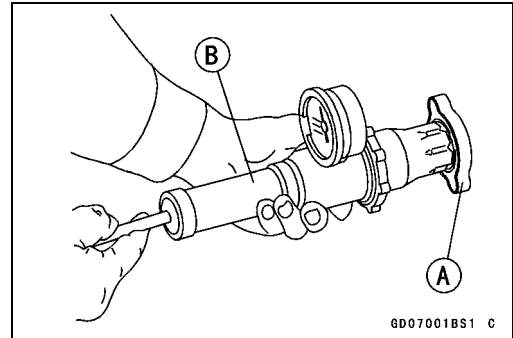

Radiator Filler Neck Inspection

- Remove the radiator cap.
- Visually inspect the radiator filler neck for signs of damage.
- Check the condition of the top and bottom seal surfaces [A] in the filler neck. They must be smooth and clean for the radiator cap to function properly.



Thermostat

Thermostat Removal

- Drain the coolant (see Coolant Change in the Periodic Maintenance chapter).
- Remove:
 - Thermostat Housing Bolts [A]
 - Thermostat Housing [B]

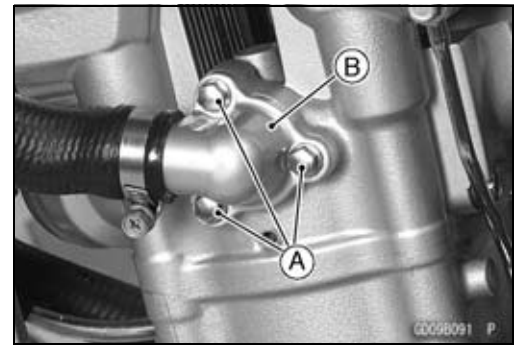

- Take off the thermostat [A] from the cylinder head.



Thermostat Installation

- Install the thermostat in the cylinder head so that the air bleeder hole [A] is on top.
- Apply a non-permanent locking agent to the threads of the thermostat housing bolts.
- Tighten:
 - Torque - Thermostat Housing Bolts: 9.8 N·m (1.0 kgf·m, 87 in·lb)**
- Fill the coolant (see Coolant Change in the Periodic Maintenance chapter).



Thermostat Inspection

- Remove the thermostat, and inspect the thermostat valve at room temperature.
- ★ If the valve is open, replace the valve with a new one.
- To check valve opening temperature, suspend the thermostat [A] and an thermometer [B] in a container of water with the heat-sensitive portions [C] in almost the same depth.

NOTE

- The thermostat must be completely submerged and must not touch the container sides or bottom.
- Gradually raise the temperature of the water while stirring the water gently for even temperature.

Thermostat Valve Opening Temperature
 69.5 °C ~ 72.5 °C (157 ~ 163°F)

- ★ If the measurement is out of the range, replace the thermostat.

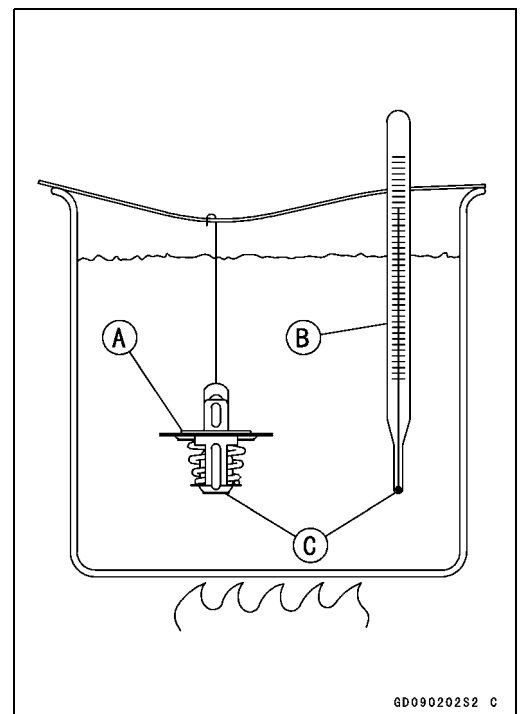

4-18 COOLING SYSTEM

Hose

Hose Installation

- Install the hoses, being careful to follow bending direction. Avoid sharp bending, kinking, flattening or twisting.
- Run the hoses (see Cable, Wire, and Hose Routing section in the Appendix chapter).
- Install the clamp [A] as near as possible to the hose end to clear the raised rib of the fitting. This will prevent the hoses from working loose.
- The clamp screws should be positioned correctly to prevent the clamps from contacting the other parts.
- Tighten:
Torque - Radiator Hose Clamp Screws: 1.5 N·m (0.15 kgf·m, 13 in·lb)

Hose Inspection

- Refer to the Radiator Hose Damage and Installation Condition Inspection in the Periodic Maintenance chapter.

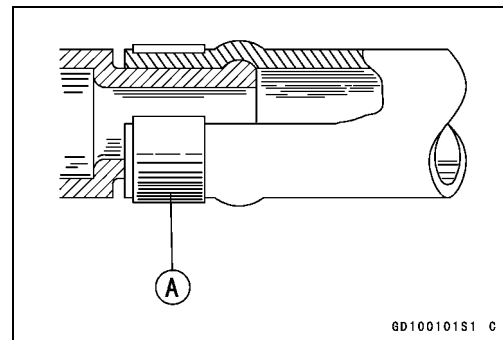

Water Temperature Sensor

Water Temperature Sensor Removal/Installation

- Refer to the Water Temperature Sensor Removal/Installation in the Fuel System (DFI) chapter.

Water Temperature Sensor Inspection

- Refer to the Water Temperature Sensor Inspection in the Electrical System chapter.

Engine Top End

Table of Contents

Exploded View	5-2	Cylinder Head Installation	5-26
Exhaust System Identification	5-6	Cylinder Head Warp	5-27
Specifications	5-7	Valve Clearance Inspection	5-27
Special Tools and Sealants	5-9	Valve Clearance Adjustment	5-27
Clean Air system	5-12	Valve	5-28
Air Suction Valve Removal	5-12	Valve Removal	5-28
Air Suction Valve Installation	5-12	Valve Installation	5-28
Air Suction Valve Inspection	5-12	Valve Guide Removal	5-28
Air Switching Valve Removal	5-12	Valve Guide Installation	5-29
Air Switching Valve Installation	5-12	Valve Guide Wear (Wobble	
Air Switching Valve Inspection	5-13	Method)	5-29
Clean Air System Hoses		Valve Seat Inspection	5-30
Inspection	5-13	Valve Seat Repair	5-30
Cylinder Head Cover	5-14	Cylinder, Piston	5-34
Cylinder Head Cover Removal	5-14	Cylinder Removal	5-34
Cylinder Head Cover Installation	5-14	Piston Removal	5-34
Camshaft Chain Tensioner	5-15	Cylinder, Piston Installation	5-35
Camshaft Chain Tensioner		Cylinder Wear	5-36
Removal	5-15	Piston Wear	5-37
Camshaft Chain Tensioner		Piston/Cylinder Clearance	5-37
Installation	5-15	Piston Ring, Piston Ring Groove	
Camshaft	5-17	Wear	5-37
Camshaft Removal	5-17	Piston Ring Groove Width	5-38
Camshaft Installation	5-18	Piston Ring Thickness	5-38
Camshaft Chain Removal	5-20	Piston Ring End Gap	5-39
Camshaft Chain Installation	5-20	Throttle Body Assy Holder	5-40
KACR (Kawasaki Automatic		Throttle Body Assy Holder	
Compression Release)		Removal	5-40
Inspection	5-21	Throttle Body Assy Holder	
Camshaft/Camshaft Cap Wear	5-22	Installation	5-40
Camshaft Runout	5-22	Mufflers	5-41
Cam Wear	5-23	Muffler Body Removal	5-41
Cylinder Head	5-24	Muffler Body Installation	5-41
Cylinder Compression		Exhaust Pipe Removal	5-42
Measurement	5-24	Exhaust Pipe Installation	5-42
Cylinder Head Removal	5-25		

5-2 ENGINE TOP END

Exploded View

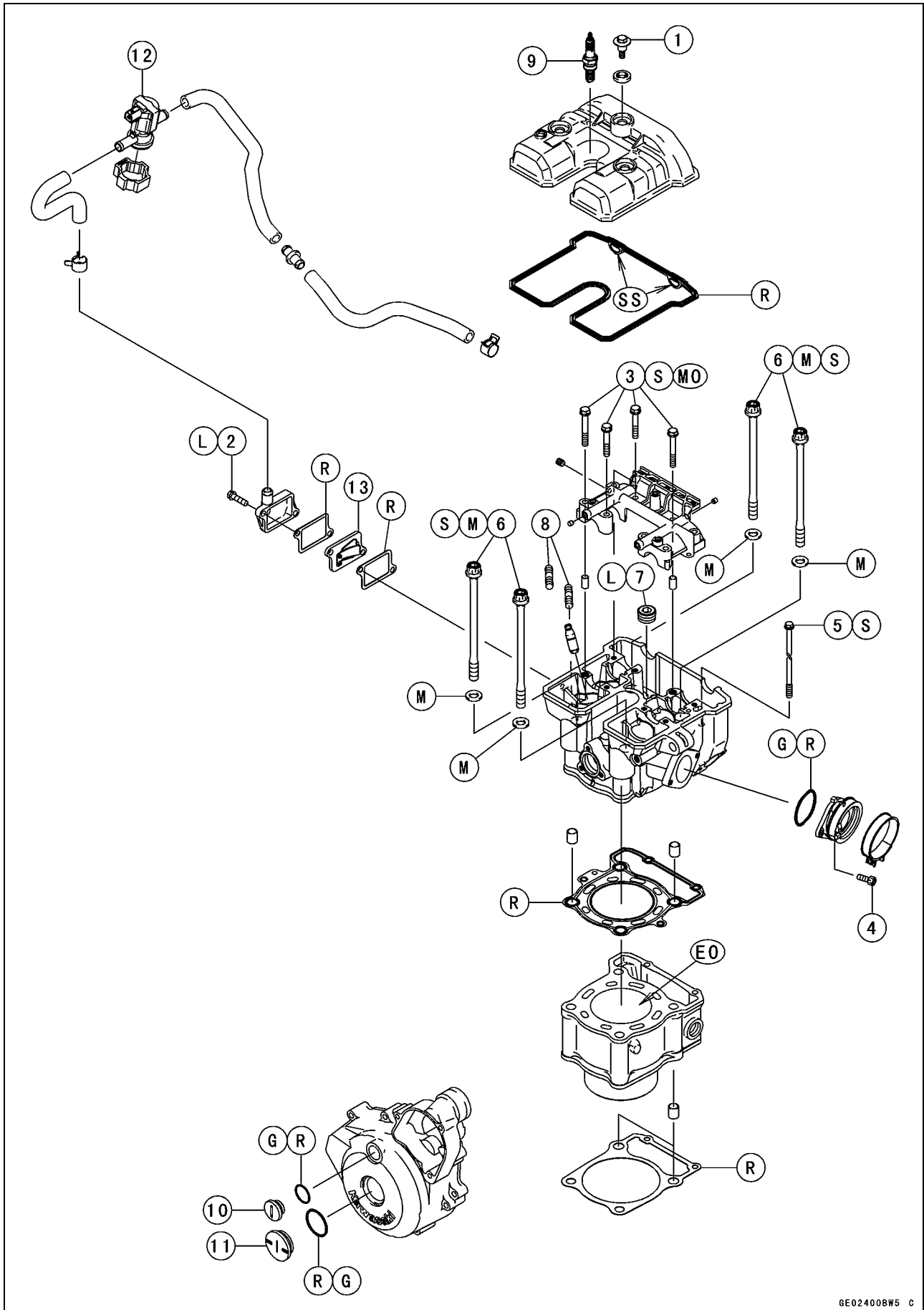

Exploded View

No.	Fastener	Torque			Remarks
		N·m	kgf·m	ft·lb	
1	Cylinder Head Cover Bolts	7.8	0.80	69 in·lb	
2	Air Suction Valve Cover Bolts	9.8	1.0	87 in·lb	L
3	Camshaft Cap Bolts	12	1.2	106 in·lb	S, MO
4	Throttle Body Assy Holder Bolts	12	1.2	106 in·lb	
5	Cylinder Head Bolts (M6)	12	1.2	106 in·lb	S
6	Cylinder Head Bolts (M10) (First)	15	1.5	11	M, S
	Cylinder Head Bolts (M10) (Final)	46	4.7	34	M, S
7	Plug	20	2.0	15	L
8	Exhaust Pipe Holder Stud Bolts	25	2.5	18	
9	Spark Plug	13	1.3	115 in·lb	
10	Timing Inspection Cap	2.3	0.23	20 in·lb	
11	Alternator Rotor Bolt Cap	2.3	0.23	20 in·lb	

12. Air Switching Valve

13. Air Suction Valve

EO: Apply engine oil.

G: Apply grease.

L: Apply a non-permanent locking agent.

M: Apply molybdenum disulfided grease.

MO: Apply molybdenum disulfided oil. (mixture of engine oil and molybdenum disulfide grease in a weight ration is 10 : 1)

R: Replacement Parts

S: Follow the specified tightening sequence.

SS: Apply silicone sealant.

5-4 ENGINE TOP END

Exploded View

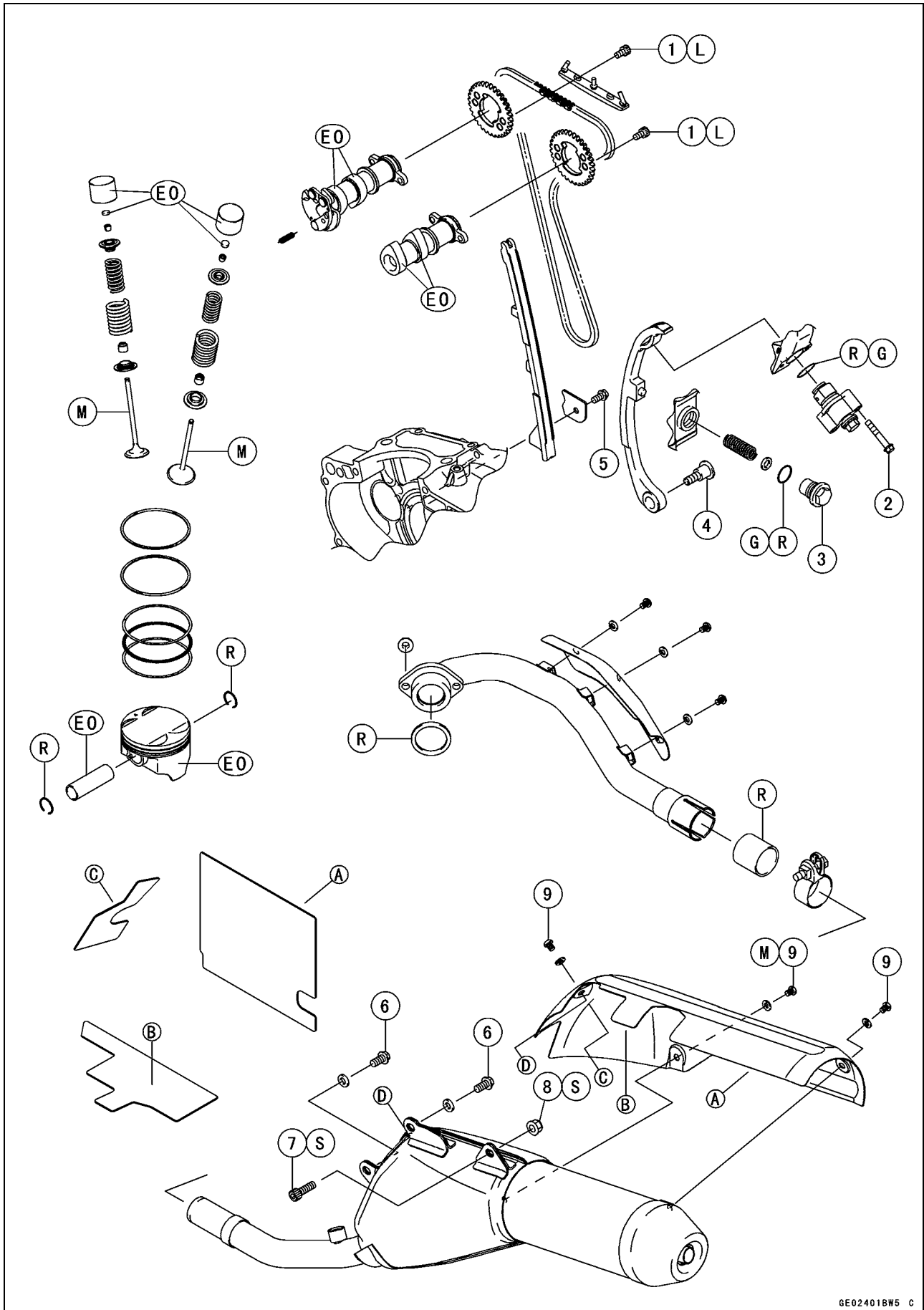

Exploded View

No.	Fastener	Torque			Remarks
		N·m	kgf·m	ft·lb	
1	Camshaft Sprocket Bolts	9.8	1.0	87 in·lb	L
2	Camshaft Chain Tensioner Bolts	9.8	1.0	87 in·lb	
3	Camshaft Chain Sub-tensioner Bolt	15	1.5	11	
4	Camshaft Chain Guide Bolt	25	2.5	18	
5	Camshaft Chain Guide Retaining Plate Bolt	9.8	1.0	87 in·lb	
6	Muffler Body Bolts (Front/Center)	30	3.0	22	
7	Muffler Body Bolt (Rear)	9.8	1.0	87 in·lb	S
8	Muffler Body Nut	30	3.0	22	S
9	Muffler Cover Bolts	9.8	1.0	87 in·lb	M (1)

EO: Apply engine oil.

G: Apply grease.

L: Apply a non-permanent locking agent.

M: Apply molybdenum disulfided grease.

R: Replacement Parts

S: Follow the specified tightening sequence.

5-6 ENGINE TOP END

Exhaust System Identification

EXHAUST PIPE	MUFFLER BODY	SPECIFICATION	MODEL
<p>Non-Catalyst</p> <hr/> <p>P/No. 18088-0512 Mark : KHI E 053</p>	<p>Honeycomb Type Catalyst with Oxygen Sensor</p> <hr/> <p>P/No. 18091-0688 Mark : KHI K 514</p>	<p>IN TH EUR SEA BR IN TH</p>	<p>KLX250S9F ~ KLX250SAF KLX250S9F ~ KLX250SAF KLX250S9F ~ KLX250SAF KLX250SAF KLX250VAF KLX250V9F ~ KLX250VAF KLX250V9F ~ KLX250VAF</p>
<p>Non-Catalyst</p> <hr/> <p>P/No. 18088-0594 Mark : KHI E 053</p>	<p>Honeycomb Type Catalyst with Oxygen Sensor</p> <hr/> <p>P/No. 18091-0729 Mark : KHI K 514</p>	<p>IN TH EUR SEA</p>	<p>KLX250SBF KLX250SBF KLX250SBF KLX250SBF</p>

GE24554B F

Exhaust Pipe Mark Position [A]

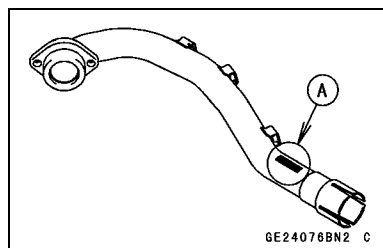

Muffler Body Mark Position [B]

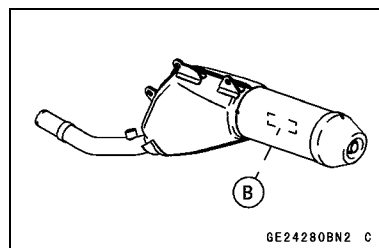

Honeycomb Type Catalyst Position [C]

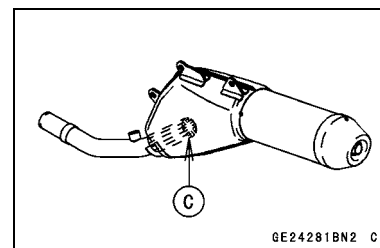

Specifications

Fastener	Standard	Service Limit
Camshaft		
Cam Height:		
Exhaust	36.246 ~ 36.354 mm (1.4270 ~ 1.4312 in.)	36.15 mm (1.423 in.)
Inlet	36.246 ~ 36.354 mm (1.4270 ~ 1.4312 in.)	36.15 mm (1.423 in.)
Camshaft/Cap Clearance	0.020 ~ 0.062 mm (0.00079 ~ 0.0024 in.)	0.15 mm (0.0059 in.)
Camshaft Journal Diameter	22.959 ~ 22.980 mm (0.90390 ~ 0.90472 in.)	22.93 mm (0.9028 in.)
Camshaft Bearing Inside Diameter	23.000 ~ 23.021 mm (0.90551 ~ 0.90633 in.)	23.08 mm (0.9086 in.)
Camshaft Runout	TIR 0.03 mm (0.001 in.) or less	TIR 0.1 mm (0.004 in.)
Cylinder Head		
Cylinder Compression:		
Usable Range	660 ~ 1 030 kPa (6.7 ~ 10.5 kgf/cm ² , 96 ~ 149 psi) @300 rpm	— — —
Cylinder Head Warp	— — —	0.05 mm (0.002 in.)
Valve		
Valve Clearance:		
Exhaust	0.15 ~ 0.24 mm (0.0059 ~ 0.0094 in.)	— — —
Inlet	0.10 ~ 0.19 mm (0.0039 ~ 0.0075 in.)	— — —
Valve Head Thickness:		
Exhaust	0.8 mm (0.03 in.)	0.5 mm (0.02 in.)
Inlet	0.5 mm (0.02 in.)	0.2 mm (0.008 in.)
Valve Stem Bend	TIR 0.01 mm (0.0004 in.) or less	TIR 0.05 mm (0.002 in.)
Valve Stem Diameter:		
Exhaust	4.455 ~ 4.470 mm (0.1754 ~ 0.1760 in.)	4.44 mm (0.175 in.)
Inlet	4.475 ~ 4.490 mm (0.1762 ~ 0.1768 in.)	4.46 mm (0.176 in.)
Valve Guide Inside Diameter:		
Exhaust	4.500 ~ 4.512 mm (0.1772 ~ 0.1776 in.)	4.58 mm (0.180 in.)
Inlet	4.500 ~ 4.512 mm (0.1772 ~ 0.1776 in.)	4.58 mm (0.180 in.)
Valve/Valve Guide Clearance (Wobble Method):		
Exhaust	0.08 ~ 0.15 mm (0.0031 ~ 0.0059 in.)	0.33 mm (0.013 in.)
Inlet	0.03 ~ 0.10 mm (0.0012 ~ 0.0039 in.)	0.28 mm (0.011 in.)
Valve Seat Cutting Angle	32°, 45°, 60°	— — —
Valve Seat Surface Outside Diameter:		
Exhaust	24.4 ~ 24.6 mm (0.961 ~ 0.968 in.)	— — —
Inlet	28.4 ~ 28.6 mm (1.118 ~ 1.126 in.)	— — —
Valve Seat Surface Width:		
Exhaust	0.5 ~ 1.0 mm (0.02 ~ 0.04 in.)	— — —
Inlet	0.5 ~ 1.0 mm (0.02 ~ 0.04 in.)	— — —

5-8 ENGINE TOP END

Specifications

Fastener	Standard	Service Limit
Valve Spring Free Length:		
Outer (EX, IN)	41.4 mm (1.63 in.)	39.6 mm (1.56 in.)
Inner (EX, IN)	36.5 mm (1.44 in.)	34.8 mm (1.37 in.)
Cylinder, Piston		
Cylinder Inside Diameter	72.000 ~ 72.012 mm (2.8346 ~ 2.8351 in.)	72.07 mm (2.837 in.)
Piston Outside Diameter	71.950 ~ 71.965 mm (2.8327 ~ 2.8333 in.)	71.80 mm (2.827 in.)
Piston/Cylinder Clearance	0.035 ~ 0.062 mm (0.0014 ~ 0.0024 in.)	— — —
Piston Ring/Groove Clearance:		
Top	0.03 ~ 0.07 mm (0.001 ~ 0.003 in.)	0.17 mm (0.0067 in.)
Second	0.03 ~ 0.07 mm (0.001 ~ 0.003 in.)	0.17 mm (0.0067 in.)
Piston Ring Groove Width:		
Top	1.02 ~ 1.04 mm (0.0402 ~ 0.0409 in.)	1.12 mm (0.0441 in.)
Second	1.02 ~ 1.04 mm (0.0402 ~ 0.0409 in.)	1.12 mm (0.0441 in.)
Oil	2.01 ~ 2.03 mm (0.0791 ~ 0.0799 in.)	2.11 mm (0.0831 in.)
Piston Ring Thickness:		
Top	0.97 ~ 0.99 mm (0.038 ~ 0.039 in.)	0.90 mm (0.035 in.)
Second	0.97 ~ 0.99 mm (0.038 ~ 0.039 in.)	0.90 mm (0.035 in.)
Piston Ring End Gap:		
Top	0.20 ~ 0.35 mm (0.0079 ~ 0.014 in.)	0.6 mm (0.02 in.)
Second	0.20 ~ 0.35 mm (0.0079 ~ 0.014 in.)	0.6 mm (0.02 in.)
Oil	0.20 ~ 0.70 mm (0.0079 ~ 0.028 in.)	1.0 mm (0.039 in.)

TIR: Total Indicator Reading of a Dial Gauge

Special Tools and Sealants

Compression Gauge 20 kgf/cm²:
57001-221

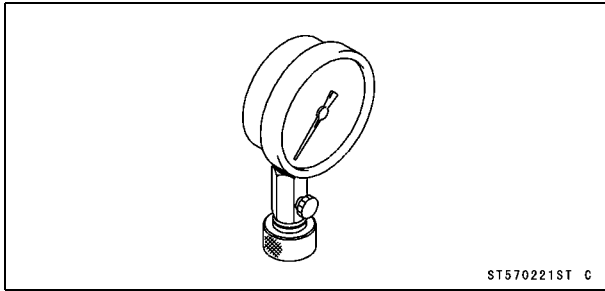

Valve Seat Cutter, 45° - ϕ 24.5:
57001-1113

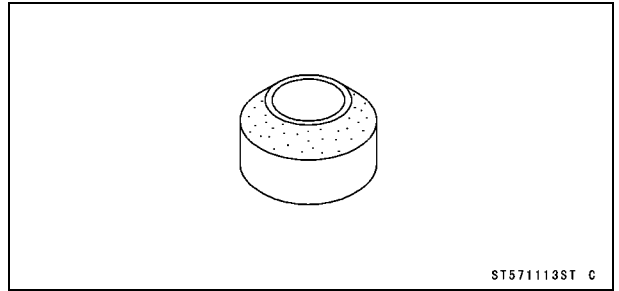

Valve Spring Compressor Assembly:
57001-241

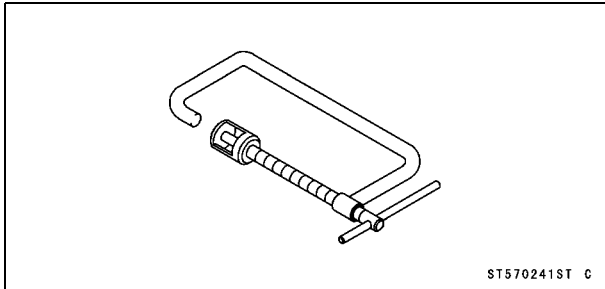

Valve Seat Cutter, 45° - ϕ 27.5:
57001-1114

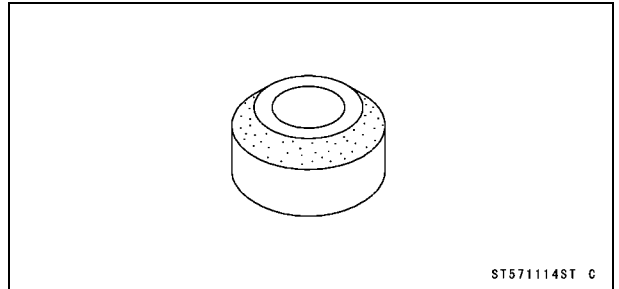

Piston Pin Puller Assembly:
57001-910

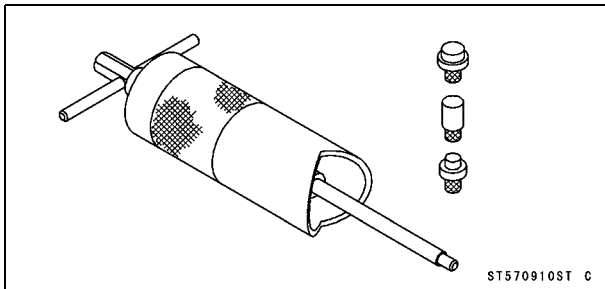

Valve Seat Cutter, 32° - ϕ 28:
57001-1119

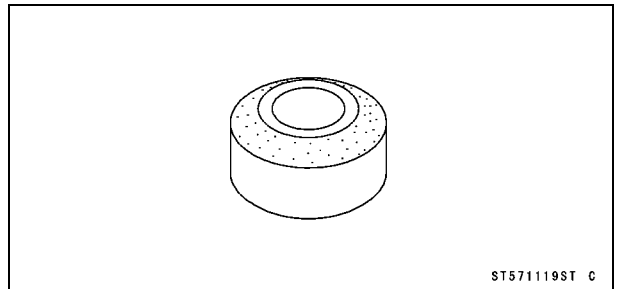

Piston Ring Compressor Grip :
57001-1095

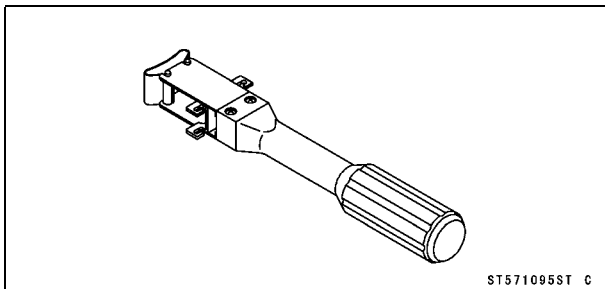

Valve Seat Cutter, 32° - ϕ 30:
57001-1120

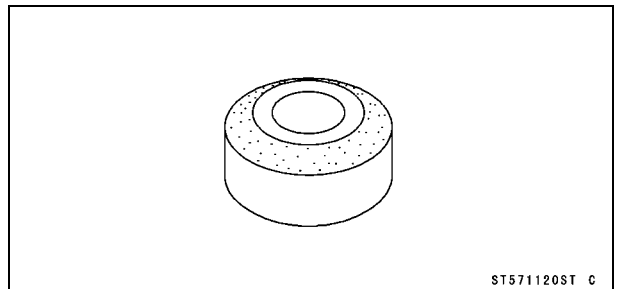

Piston Ring Compressor Belt, ϕ 67 ~ ϕ 79:
57001-1097

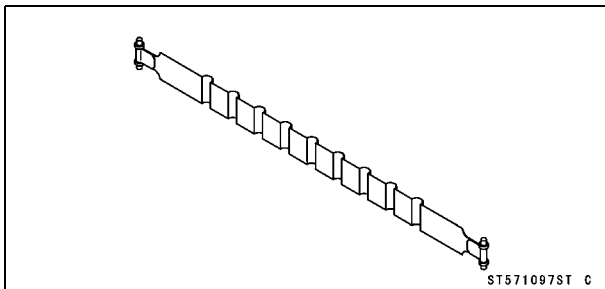

Valve Seat Cutter, 60° - ϕ 30:
57001-1123

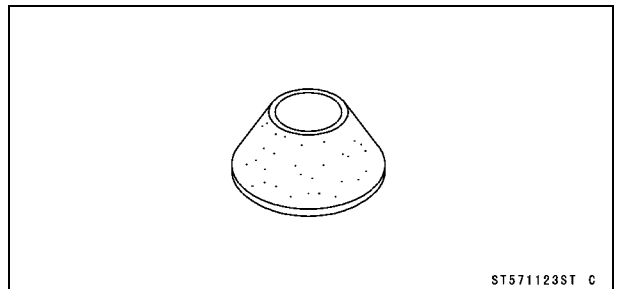

5-10 ENGINE TOP END

Special Tools and Sealants

Valve Seat Cutter Holder Bar:

57001-1128

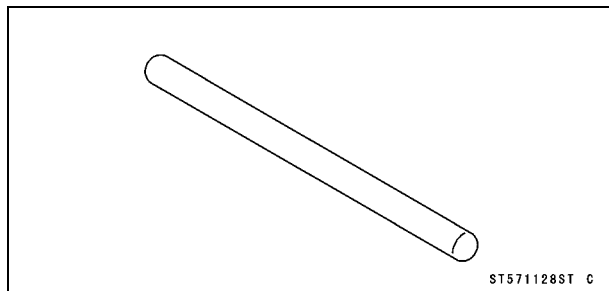

ST571128ST C

Valve Guide Arbor $\phi 4.5$:

57001-1331

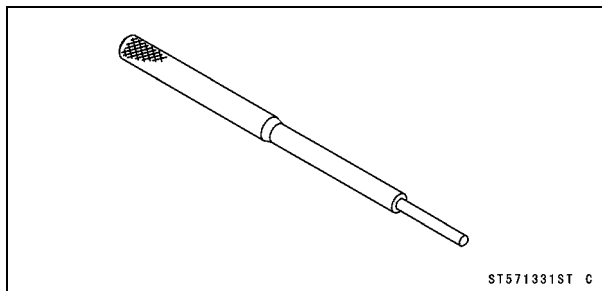

ST571331ST C

Spark Plug Wrench, Hex 16:

57001-1262

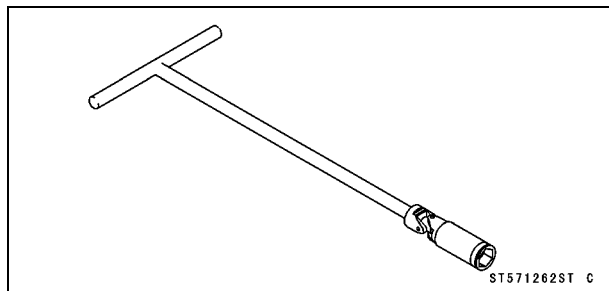

ST571262ST C

Valve Guide Reamer $\phi 4.5$:

57001-1333

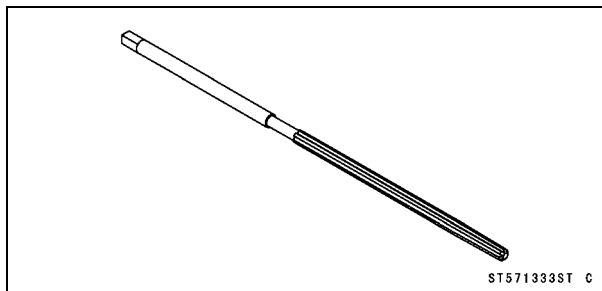

ST571333ST C

Compression Gauge Adapter M10 \times 1.0:

57001-1317

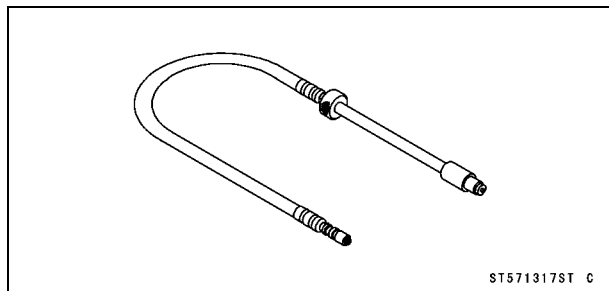

ST571317ST C

Filler Cap Driver:

57001-1454

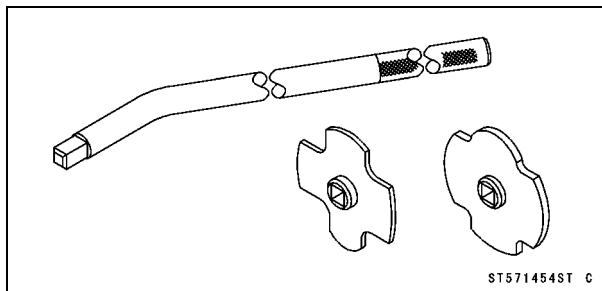

ST571454ST C

Valve Seat Cutter, 60° - $\phi 25$:

57001-1328

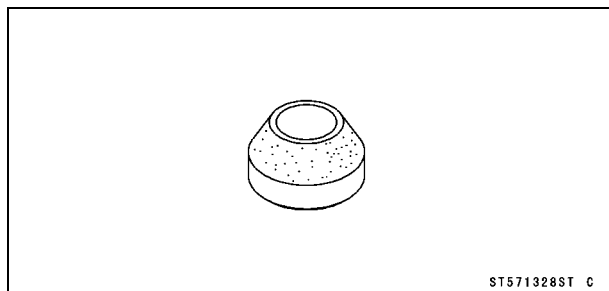

ST571328ST C

Valve Guide Driver:

57001-1564

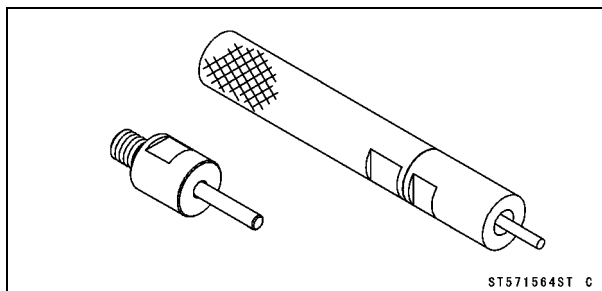

ST571564ST C

Valve Seat Cutter Holder, $\phi 4.5$:

57001-1330

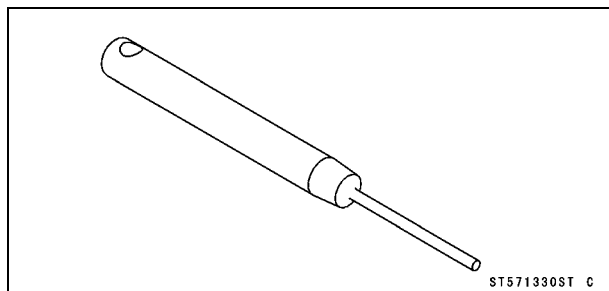

ST571330ST C

Valve Spring Compressor Adapter, $\phi 24$:

57001-1586

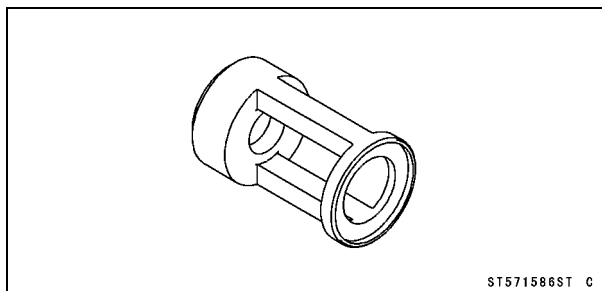

ST571586ST C

Special Tools and Sealants

**Valve Guide Driver Attachment F:
57001-1722**

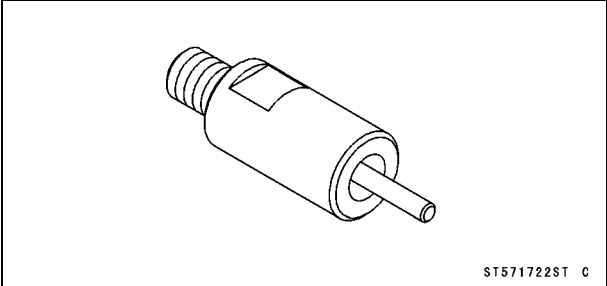

**Liquid Gasket, TB1211:
56019-120**

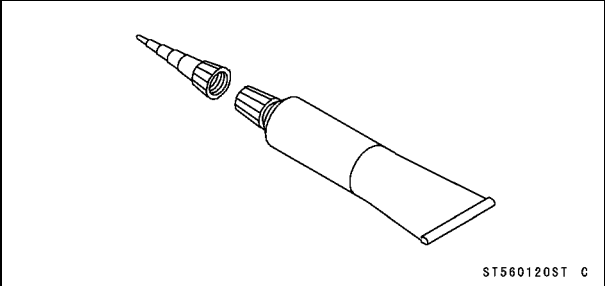

**Liquid Gasket, TB1216B:
92104-1064**

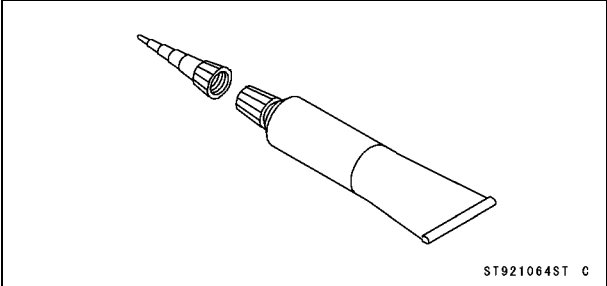

5-12 ENGINE TOP END

Clean Air system

Air Suction Valve Removal

- Remove:
 - Air Suction Valve Cover Bolts [A]
 - Air Suction Valve Cover [B]
 - Air Suction Valve [C]

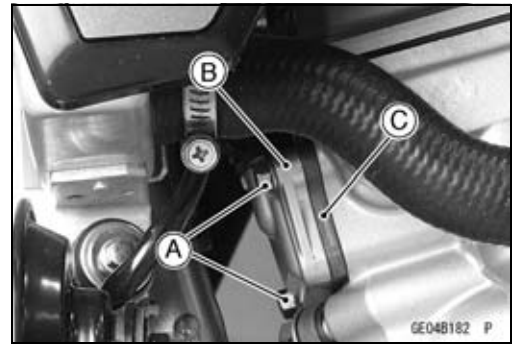

Air Suction Valve Installation

- Replace the gaskets with new ones.
- Install a gasket in such a manner that the 5 mm (0.20 in.) side [A] faces downward [C].
- 6 mm (0.24 in.) [B]
- Apply a non-permanent locking agent to the thread of the air suction valve cover bolts, and tighten them.

Torque - Air Suction Valve Cover Bolts: 9.8 N·m (1.0 kgf·m, 87 in·lb)

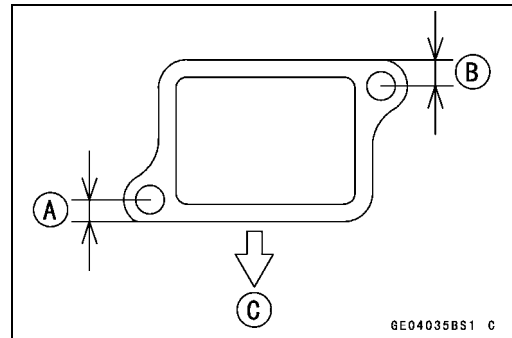

Air Suction Valve Inspection

- Remove the air suction valve (see Air Suction Valve Removal).
- Visually inspect the reed [A] for cracks, folds, warps, heat damage, or other damage.
- ★ If there is any doubt as to the condition of the reed, replace the air suction valve as an assembly.
- Check the reed contact area [B] of the valve holder for grooves, scratches, any signs of separation from the holder, or heat damage.
- ★ If there is any doubt as to the condition of the reed contact areas, replace the air suction valve as an assembly.
- If any carbon or other foreign particles have accumulated between the reed and the reed contact area, wash the valve assembly with a high flash-point solvent.

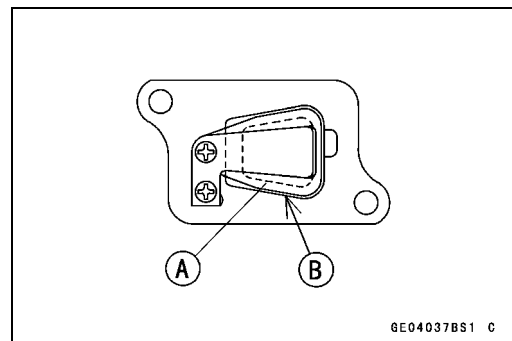

NOTICE

Do not scrape off the deposits with a scraper as this could damage the rubber, requiring replacement of the suction valve assembly.

Air Switching Valve Removal

- Remove:
 - Fuel Tank (see Fuel Tank Removal in the Fuel System (DFI) chapter)
- Disconnect the air switching valve connector [A] and pull off the hoses [B].
- Remove the air switching valve [C].

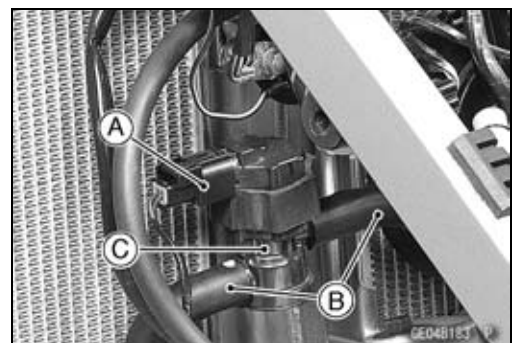

Air Switching Valve Installation

- Route the hoses correctly (see Cable, Wire and Hose Routing section in the Appendix chapter).

Clean Air system

Air Switching Valve Inspection

- Refer to the Air Switching Valve Unit Test in the Electrical System chapter.

Clean Air System Hoses Inspection

- Remove the left radiator shroud (see Radiator Shroud Remove in the Frame chapter).
- Air switching valve hose [A] is detached by fitting part [B] in the middle.
- The engine is started, and it is rotated at the idling speed.
- The edge of air switching valve hose is closed with the finger, and it is confirmed that in hose becomes negative pressure.
- ★ If not negative pressure, it checks for leaks to the hose line. When there is no leakage, next inspection.
 - Air Switching Valve (see Air Switching Valve Inspection in the Electrical System)
 - Air Suction Valve (see Air Suction Valve Inspection)

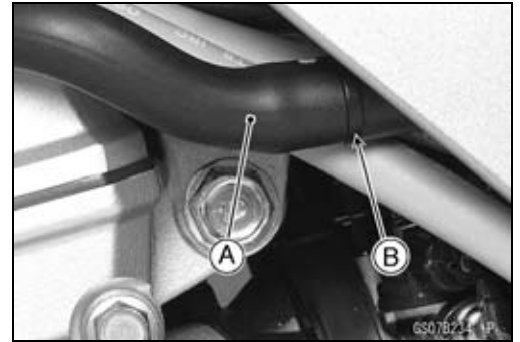

5-14 ENGINE TOP END

Cylinder Head Cover

Cylinder Head Cover Removal

- Remove:
 - Fuel Tank (see Fuel Tank Removal in the Fuel System (DFI) chapter)
 - Heat Guard [A]
 - Cylinder Head Cover Bolts [B]

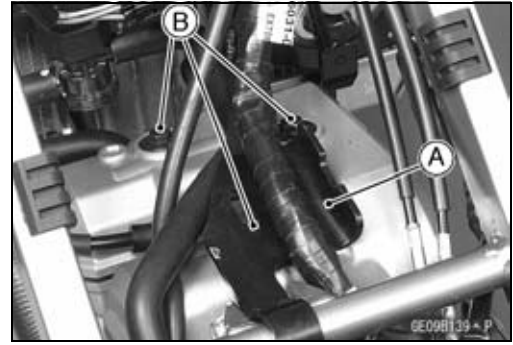

- While pushing the right radiator forward, remove the cylinder head cover [A] from the left side.

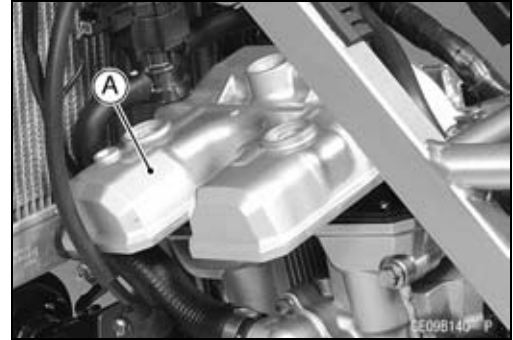

Cylinder Head Cover Installation

- Replace the cylinder head cover gasket [A] with a new one.
- Insert the protrusion of a gasket into the groove of the cylinder head cover securely.
- Apply silicone sealant [B] to the cylinder head cover gasket as shown.

Sealant - Liquid Gasket, TB1211: 56019-120

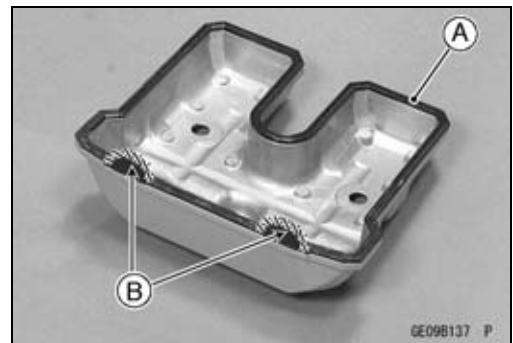

- Install the cylinder head cover together with the gasket.
- Install the head cover bolt washers [A] with the metal side upwards.
- Tighten:

Torque - Cylinder Head Cover Bolts [B]: 7.8 N·m (0.80 kgf·m, 69 in·lb)

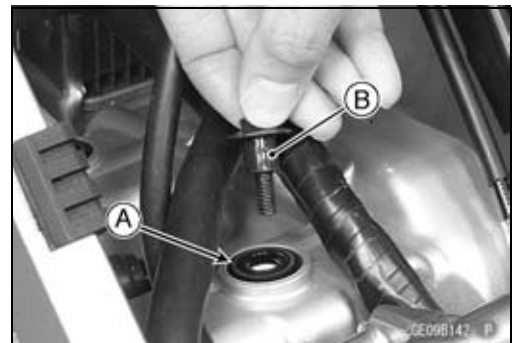

Camshaft Chain Tensioner

Camshaft Chain Tensioner Removal

NOTICE

This is a non-return type camshaft chain tensioner. The push rod does not return to its original position once it moves out to take up camshaft chain slack. When removing the tensioner, do not take out the mounting bolts only halfway. Retightening the mounting bolts from this position could damage the tensioner and the camshaft chain. Once the bolts are loosened, the tensioner must be removed and reset as described in "Camshaft Chain Tensioner Installation".

Do not turn over the crankshaft while the tensioner is removed. This could upset the cam chain timing, and damage the valves.

- Remove the exhaust pipe (see Exhaust Pipe Removal)
- Remove the tensioner cap bolt [B] before loosening the chain tensioner bolts [A].
- Remove:
 - Chain Tensioner Bolts
 - Chain Tensioner
 - Sub Chain Tensioner [C]

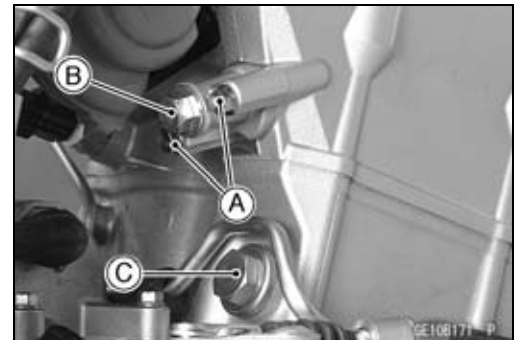

Camshaft Chain Tensioner Installation

NOTICE

Always install the camshaft chain tensioner after timing the cam shaft chain.

- Push the stopper [A] to release the ratchet and push the push rod [B] into the tensioner body.
- Install the tensioner body [A], and tighten the mounting bolts [B].
Torque - Camshaft Chain Tensioner Bolts: 9.8 N·m (1.0 kgf·m, 87 in·lb)

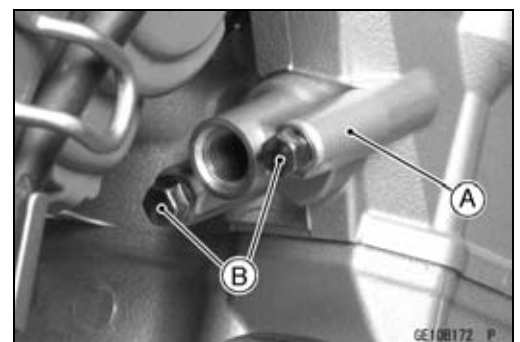
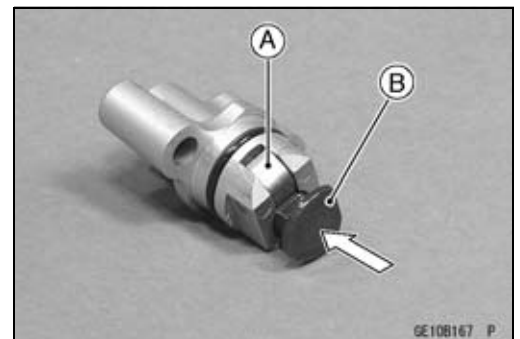

5-16 ENGINE TOP END

Camshaft Chain Tensioner

- Install the spring [A] and washer [B].
- Tighten the tensioner cap bolt [C] securely.

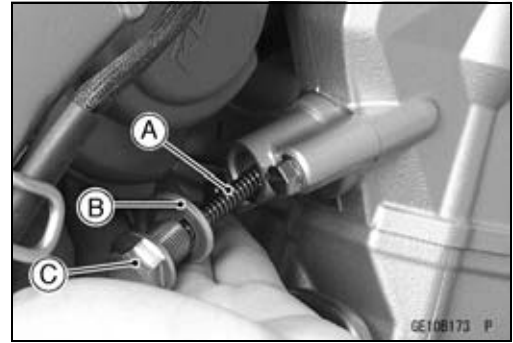

- Replace the O-ring [A] with a new one.
 - Install the spring [B].
 - Tighten:
 - Torque - Camshaft Chain Sub-tensioner Bolt [C]: 15 N·m (1.5 kgf·m, 11 ft·lb)**
- The washer [D] is placed between the sub-tensioner bolt and the spring.

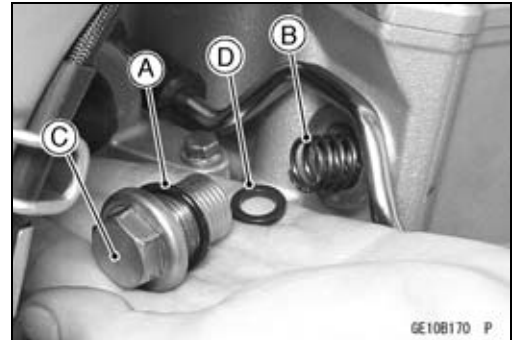

Camshaft

Camshaft Removal

- Remove the timing inspection cap [A] and alternator rotor bolt cap [B].

Special Tool - Filler Cap Driver: 57001-1454

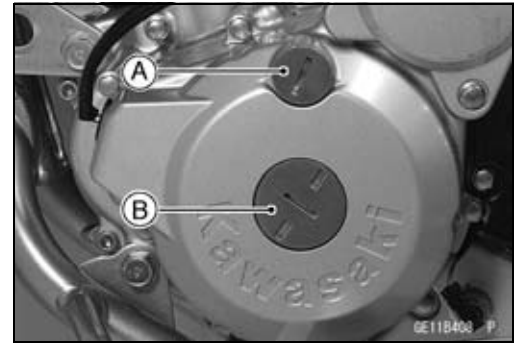

- Turn the crankshaft counterclockwise [A] and align the “T” mark line [B] of the rotor with the notch [C] of the alternator cover.
- Remove:
 - Cylinder Head Cover (see Cylinder Head Cover Removal)
 - Camshaft Chain Tensioner (Camshaft Chain Tensioner Removal)
 - Sub-tensioner (Camshaft Chain Tensioner Removal)

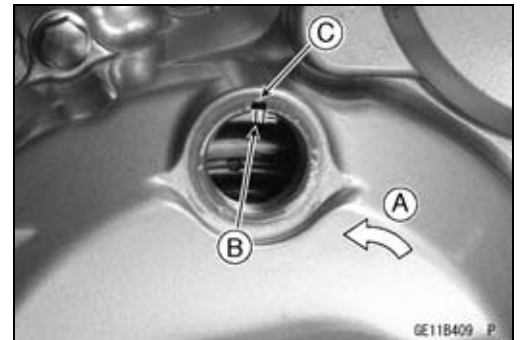

- Remove:
 - Camshaft Cap Bolts [A]
 - Camshaft Cap [B]

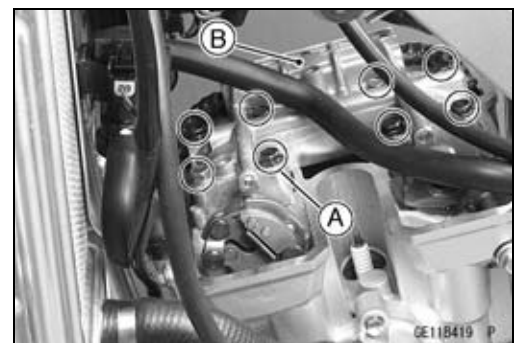

- Remove the camshafts [A] from the camshaft chain [B].
- Stuff a clean cloth into the chain tunnel to keep any parts from dropping into the crankcase.

NOTICE

The crankshaft may be turned while the camshafts are removed. Always pull the chain taut while turning the crankshaft. This avoids kinking the chain on the lower (crankshaft) sprocket. A kinked chain could damage the crankcase.

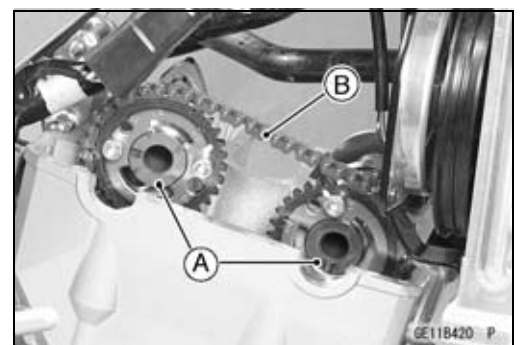

- Remove:
 - Camshaft Chain Sprocket Bolts [A]
 - Camshaft Chain Sprocket [B]

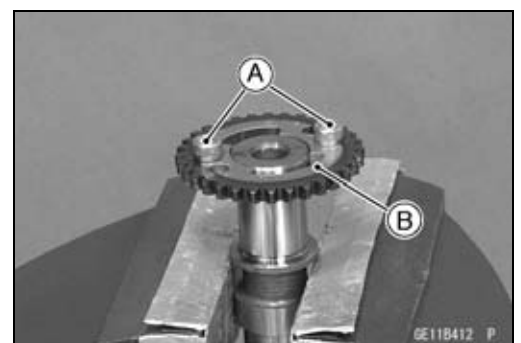

5-18 ENGINE TOP END

Camshaft

Camshaft Installation

Sprockets are the same for both inlet and exhaust sides.

- Install the sprocket on the camshaft so that the marked side faces out.

NOTE

○ Install sprockets to the camshafts with a sprocket aligned with the IN mark [A] for the inlet side camshaft [B] and the other, with the EX mark [C] for the exhaust side camshaft [D].

- Apply a non-permanent locking agent to the threads of the camshaft sprocket bolts, and tighten them.

Torque - Camshaft Sprocket Bolts: 9.8 N·m (1.0 kgf·m, 87 in·lb)

- Apply engine oil to the entire circumference of the cam.
- When either camshaft or cylinder head was replaced with a new one, apply molybdenum disulfide oil to the entire circumference of the cam.
- Install the camshafts.
- The exhaust side camshaft [A] is equipped with a compression release mechanism [B].

- Position the piston at TDC.
- Turn the crankshaft counterclockwise [A] and align the "T" mark line [B] of the rotor with the notch [C] of the alternator cover.

- Engage the camshaft chain with the camshaft sprocket.

NOTE

○ Always pull the tension side (exhaust side) of the chain taut.

- Pull the tension side (exhaust side) of the chain taut to install the chain.
- The timing marks on the sprocket must be aligned with the cylinder head upper surface.
- Pull the chain taut and fit it onto the camshaft sprocket.
- Starting with the timing mark on the front of the exhaust sprocket, count to the 1st pin. Feed the exhaust camshaft through the chain and align the 32th pin with the cylinder head upper surface.

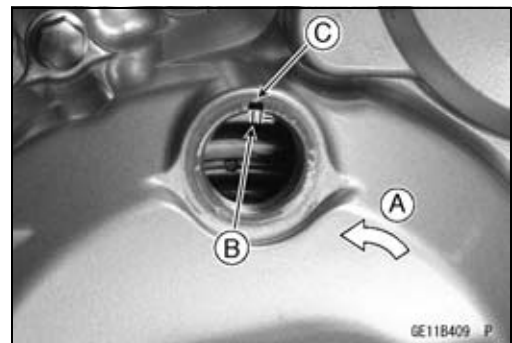
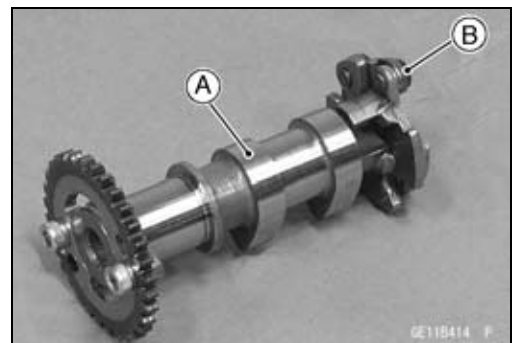
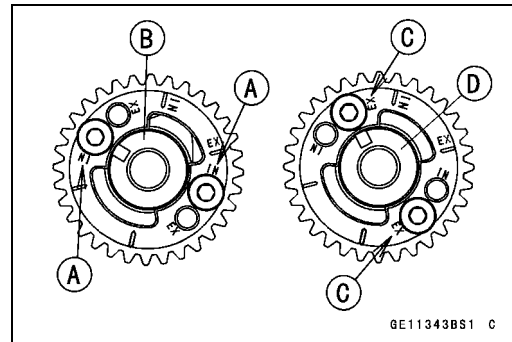

Camshaft

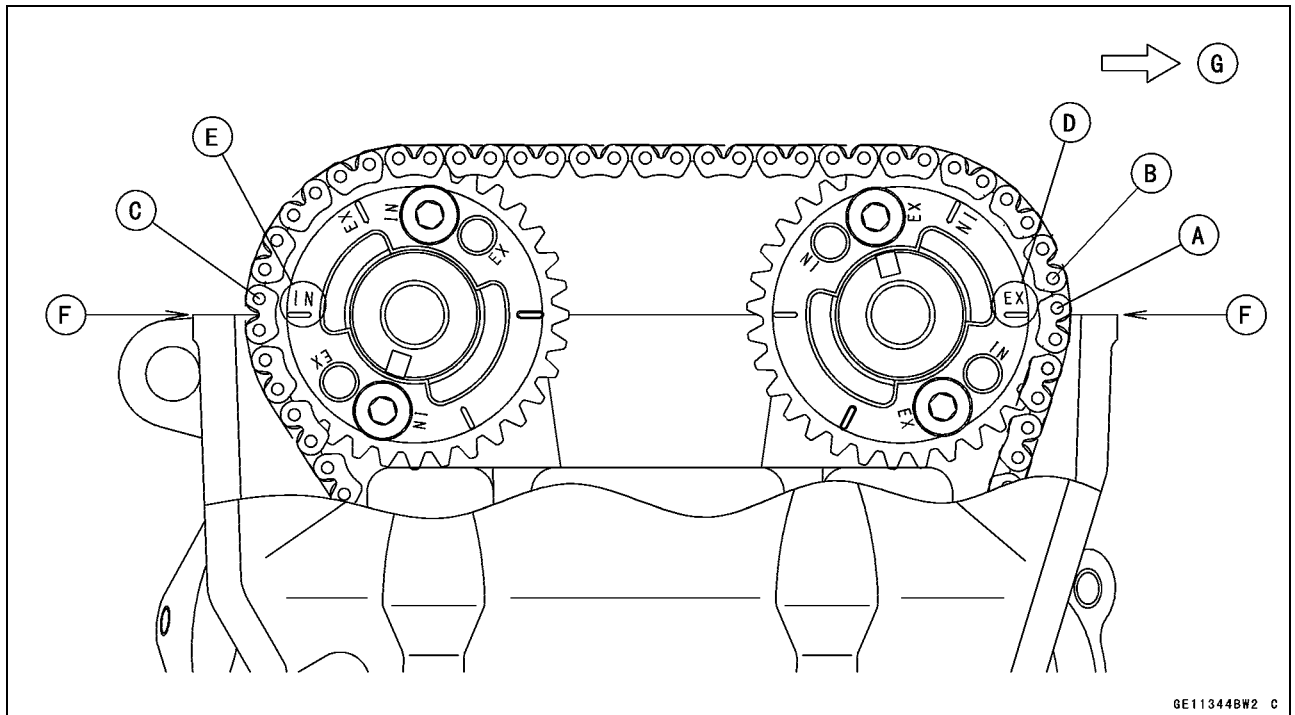

1st Pin [A]
 2nd Pin [B]
 32th Pin [C]
 EX Mark [D]

IN Mark [E]
 Cylinder Head Upper Surface [F]
 Front [G]

- Be sure to install the dowel pins [A].



- Be sure to no damage on the chain guide [A].
- ★ If chain guide is damaged, replace it with a new one.

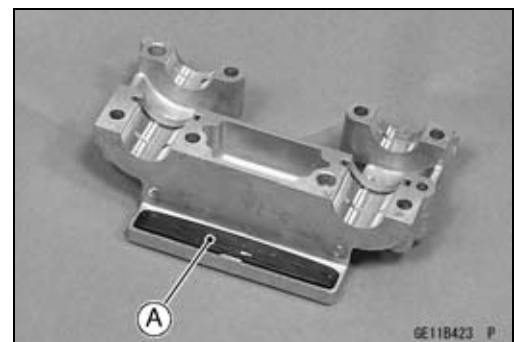

5-20 ENGINE TOP END

Camshaft

- Install the camshaft cap.
- Apply molybdenum disulfide oil to the threads and seating surface of the camshaft cap bolt.
- Tighten the camshaft cap bolts.
 - Longer Bolts [A]
 - Front [B]

NOTE

○ First gradually tighten the bolt (1) and (2) evenly to seat the camshaft in place, then tighten all bolts following the specified tightening sequence.

Torque - Camshaft Cap Bolts: 12 N·m (1.2 kgf·m, 106 in·lb)

NOTICE

After assembling the camshaft and the chain, turn the crankshaft counterclockwise for two rotations and check if the “T” mark of the rotor, the exhaust side sprocket timing mark (EX mark) and the inlet side sprocket timing mark (IN mark) align with each other.
Correct deviations, if any.

Camshaft Chain Removal

- Remove:
 - Clutch (see Clutch Removal in the Clutch chapter)
 - Oil Pump (see Oil Pump Removal in the Engine Lubrication System chapter)
 - Camshafts (see Camshaft Removal)
 - Camshaft Chain Guide Bolt [A]
 - Rear Camshaft Chain Guide [B]
 - Camshaft Chain Guide Retaining Plate Bolt [C]
 - Front Camshaft Chain Guide [D]
 - Camshaft Chain [E]

Camshaft Chain Installation

- Hang the camshaft chain to the crankshaft sprocket.
- Install:
 - Rear Camshaft Chain Guide [A]
 - Front Camshaft Chain Guide [B]
- Tighten:
 - Torque - Camshaft Chain Guide Bolt [C]: 25 N·m (2.5 kgf·m, 18 ft·lb)**
 - Camshaft Chain Guide Retaining Plate Bolt [D]: 9.8 N·m (1.0 kgf·m, 87 in·lb)**

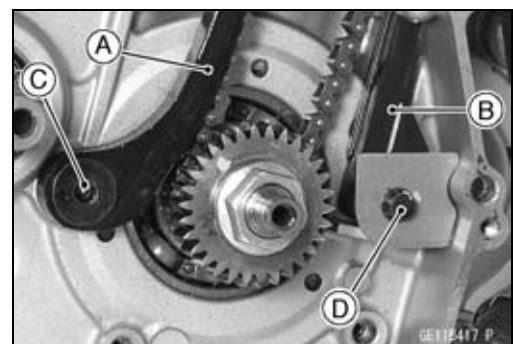
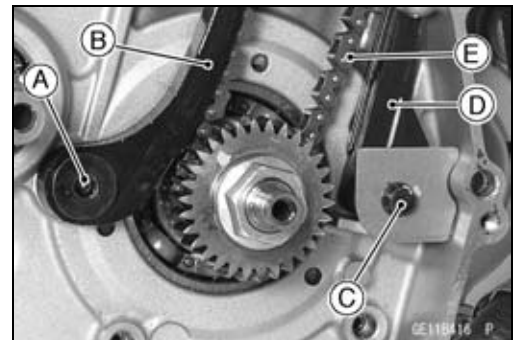
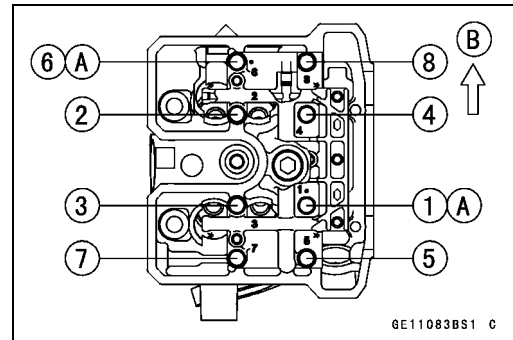

Camshaft

KACR (Kawasaki Automatic Compression Release) Inspection

KACR [B] is installed on the left end of the exhaust camshaft [A]. Do not remove or disassemble KACR alone.

○ Since KACR is the simple construction, it does not require periodic maintenance. The KACR mechanism may develop two types of failures. They are failing to release compression pressure in starting the engine and releasing compression pressure while the engine is running.

○ When compression pressure in the cylinder is not released in starting the engine (an error event), the pin [A] remains in the cam [B], so that the exhaust valve is not pushed down, which results in hard starting due to difficulty to increase the crank shaft rotation speed.

- Visually inspect the spring [C].
- ★ If the spring is damaged, deformed or lost, replace it.
- Remove the spring, and move the weights [D] and [E] back and forth.
- ★ If the weights do not move freely, replace the exhaust camshaft and KACR as a set.

Stopper [F]

○ When compression pressure in the cylinder is released while the engine is rotating (an error event), the pin [A] remains in the cam [B], so that the exhaust valve is pushed down, which results in engine stalling due to poor ignition, because a fuel-air mixture is not properly compressed.

- Move the weights [D] and [E] back and forth.
- ★ If you cannot move the weights from their retracted positions, replace the exhaust camshaft and KACR as a set.

Spring [C]

Stopper [F]

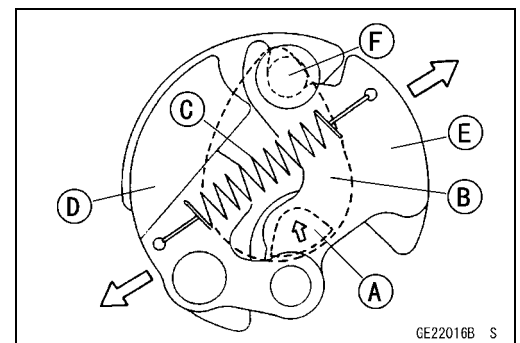
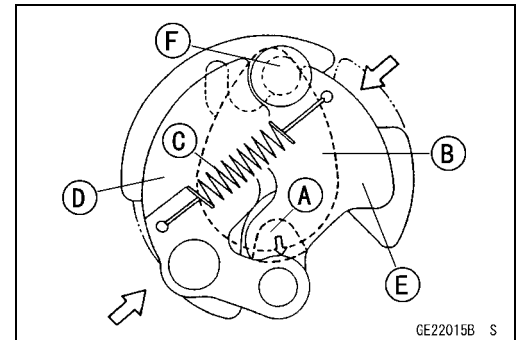
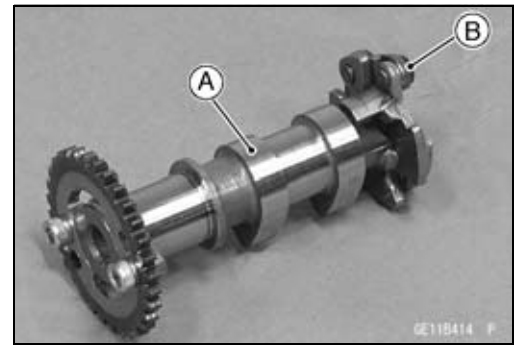

5-22 ENGINE TOP END

Camshaft

Camshaft/Camshaft Cap Wear

- Cut the strips of plastigage to journal width. Place a strip on each journal parallel to the camshaft installed in the correct position.
- Measure each clearance between the camshaft and the camshaft cap using plastigage [A].
- Install the camshaft cap (see Camshaft Installation).

NOTE

○ Do not turn the camshaft when the plastigage is between the journal and camshaft cap.

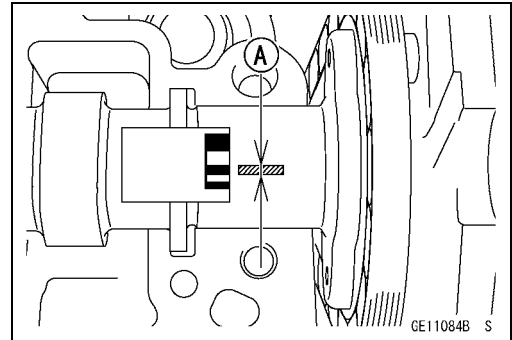

Camshaft/Camshaft Cap Clearance

Standard: 0.020 ~ 0.062 mm (0.00079 ~ 0.0024 in.)

Service Limit: 0.15 mm (0.0059 in.)

- ★ If any clearance exceeds the service limit, measure the diameter of each camshaft journal with a micrometer.

Camshaft Journal Diameter

Standard: 22.959 ~ 22.980 mm (0.90390 ~ 0.90472 in.)

Service Limit: 22.93 mm (0.9028 in.)

- ★ If the camshaft journal diameter is less than the service limit, replace the camshaft with a new one and measure the clearance again.
- ★ If the clearance still remains out of the limit, replace the cylinder head and camshaft cap.

NOTICE

The camshaft cap and cylinder head are machined at the factory in the assembled state, so they must be replaced as a set.

Camshaft Runout

- Remove the camshaft (see Camshaft Removal).
- Set the camshaft in a camshaft alignment jig or on V blocks.
- Measure the runout with a dial gauge at the specified place as shown.

Camshaft Runout

Standard: TIR 0.03 mm (0.001 in.) or less

Service Limit: TIR 0.1 mm (0.004 in.)

- ★ If the runout exceeds the service limit, replace the camshaft.

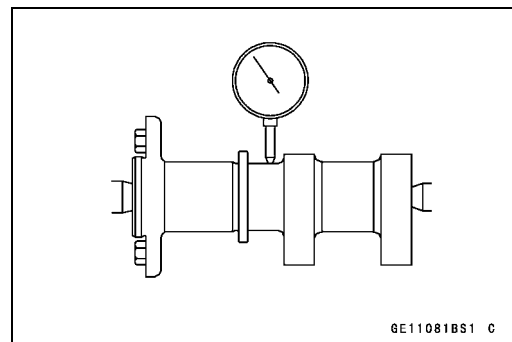

Camshaft

Cam Wear

- Remove the camshaft (see Camshaft Removal).
- Measure the height [A] of each cam with a micrometer.
- ★ If the cams are worn down past the service limit, replace the camshaft.

Cam Height

Standard:

Inlet 36.246 ~ 36.354 mm (1.4270 ~ 1.4312 in.)

Exhaust 36.246 ~ 36.354 mm (1.4270 ~ 1.4312 in.)

Service Limit:

Inlet 36.15 mm (1.423 in.)

Exhaust 36.15 mm (1.423 in.)

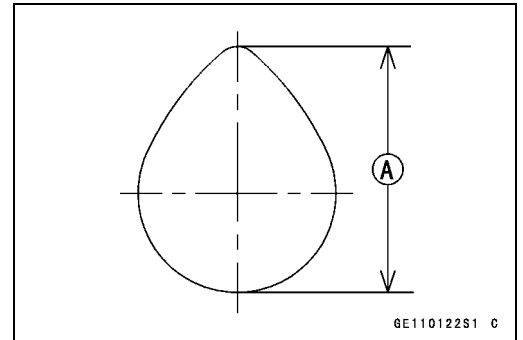

5-24 ENGINE TOP END

Cylinder Head

Cylinder Compression Measurement

NOTE

○ Use the battery which is fully charged.

- Warm up the engine thoroughly.
- Stop the engine.
- Remove:
 - Right and Left Radiator Shrouds
 - Fuel Tank (see Fuel Tank Removal in the Fuel System (DFI) chapter)
- Remove the spark plug with the spark plug wrench.

Special Tool - Spark Plug Wrench, Hex16: 57001-1262

- Install a compression gauge [A] and adapter [B] onto the plug hole in such a manner that no compression pressure is released.
- Measure the compression.
- Obtain the maximum gauge reading by turning the crank shaft with the starter motor with the throttle grip kept in the full open position.

Special Tools - Compression Gauge 20 kgf/cm²: 57001-221
Compression Gauge Adapter M10 × 1.0: 57001-1317

Cylinder Compression (Usable Range)

660 ~ 1 030 kPa (6.7 ~ 10.5 kgf/cm², 96 ~ 149 psi) @300 r/min (rpm)

- Install the spark plug.

Torque - Spark Plug: 13 N·m (1.3 kgf·m, 115 in·lb)

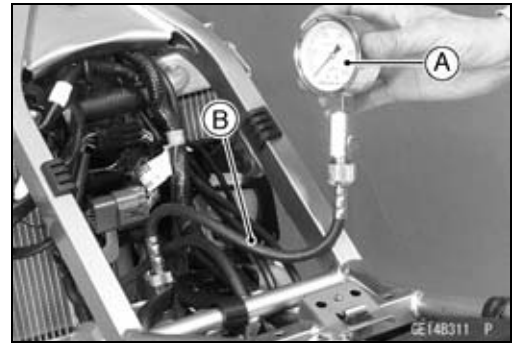

Cylinder Head

★ The following table should be consulted if the obtainable compression reading is not within the usable range.

Problems	Diagnosis	Required Action
Cylinder compression is higher than usable range	Carbon buildup on piston or in combustion chamber possibly due to damaged valve stem, valve guide stem oil seal and/or damaged piston oil rings.	Remove the carbon deposits. If necessary, replace damaged parts.
	Incorrect cylinder head gasket thickness	Replace the gasket with a standard part.
	The KACR cam spring is damaged or missing.	Replace the exhaust camshaft.
	The KACR weight does not move smoothly.	Replace the exhaust camshaft.
Cylinder compression is lower than usable range	Gas leakage around the cylinder head	Replace damaged gasket and check cylinder head warp.
	Bad condition of valve seats, valves, and valve springs	Repair them if possible.
	The valve clearance is small.	Adjust the valve clearance.
	Incorrect piston/cylinder clearance	Replace the piston or the cylinder.
	Piston seizure	Inspect the cylinder and replace/repair the cylinder and/or piston as necessary.
	Bad condition of piston ring and/or piston ring grooves.	Replace the piston and/or the piston rings.
	The KACR weight does not move smoothly.	Replace the exhaust camshaft.

Cylinder Head Removal

- Drain the coolant (see Coolant Change in the Periodic Maintenance chapter).
- Remove:
 - Thermostat (see Thermostat Removal in the Cooling System chapter)
 - Fuel Tank (see Fuel Tank Removal in the Fuel System (DFI) chapter)
 - Exhaust Pipe (see Exhaust Pipe Removal)
 - Throttle Body Assy (see Throttle Body Assy Removal in the Fuel System (DFI) chapter)
 - Camshaft (see Camshaft Removal)
 - Upper Engine Mounting Bolt [A] and Nut
 - Upper Engine Bracket Bolts [B]
 - Upper Engine Brackets [C]
 - Oil Pipe Banjo Bolt [D]
 - Water Temperature Sensor Connector [E]

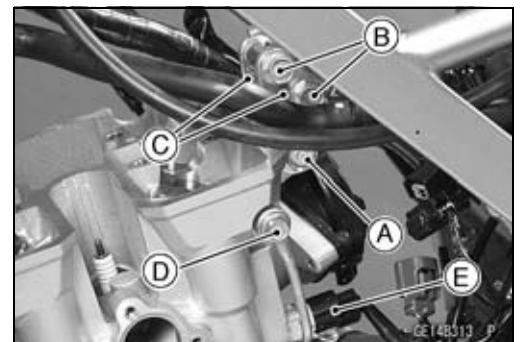

5-26 ENGINE TOP END

Cylinder Head

- Remove the hose [A] from air suction valve cover.



- Remove the front chain guide [A].
- Remove the cylinder head bolts in the following sequence:
 - (1) M6 Bolts [B]
 - (2) M10 Allen Bolts [C]

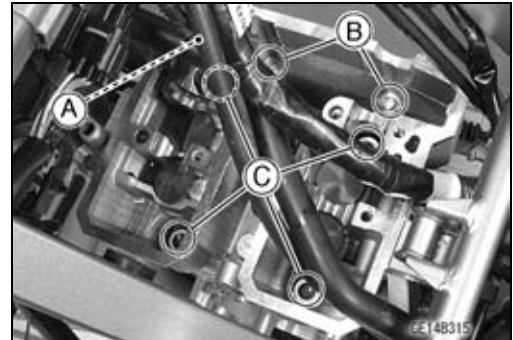

- Remove the cylinder head [A].

NOTE

○If it is hard to remove it, tap lightly using a plastic-faced mallet [B].

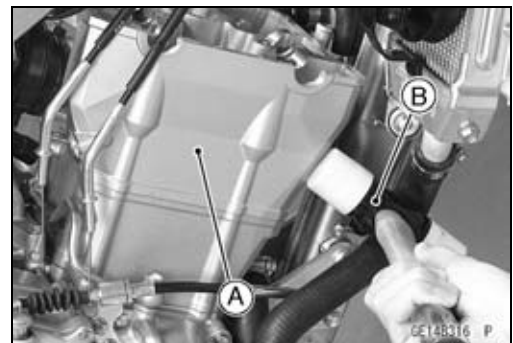

Cylinder Head Installation

- Install the dowel pins [A] and new cylinder gasket [B].
- Install the cylinder head.

NOTE

○The camshaft cap is machined with the cylinder head, so if a new cylinder head is installed, use the cap that is supplied with the new head.

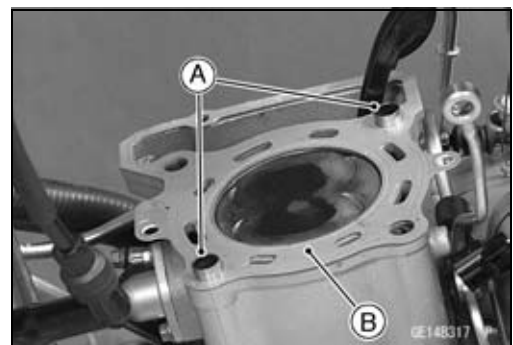

Cylinder Head

- Apply a molybdenum disulfide grease to both surfaces and threads of the cylinder head bolts (M10) washers.
- Temporarily tighten the cylinder head bolts (M10) and tighten them with specified torque in accordance with the sequence numbers [1 to 4].

Torque - Cylinder Head Bolts (M10):

(First) 15 N·m (1.5 kgf·m, 11 ft·lb)

(Final) 46 N·m (4.7 kgf·m, 34 ft·lb)

- Tighten the cylinder head bolts (M6).

Torque - Cylinder Head Bolts (M6): 12 N·m (1.2 kgf·m, 106 in·lb)

- Remove the front chain guide.
- Replace the oil pipe banjo bolt washers with new ones, and tighten the oil pipe banjo bolts.

Torque - Oil Pipe Banjo Bolt (M8): 9.8 N·m (1.0 kgf·m, 87 in·lb)

- Install removed parts (see appropriate chapters).

Cylinder Head Warp

- Lay a straightedge across the lower surface of the cylinder head at several positions.
- Measure the gap between the straightedge [B] and the head with a thickness gauge [A].

Cylinder Head Warp

Standard: ---

Service Limit: 0.05 mm (0.002 in.)

- ★ If the cylinder head is warped more than the service limit, replace it.
- ★ If the cylinder head is warped less than the service limit, repair the head by rubbing the lower surface on emery paper secured to a surface plate (first No.200, then No.400).

Valve Clearance Inspection

- Refer to the Valve Clearance Inspection in the Periodic Maintenance chapter.

Valve Clearance Adjustment

- Refer to the Valve Clearance Adjustment in the Periodic Maintenance chapter.

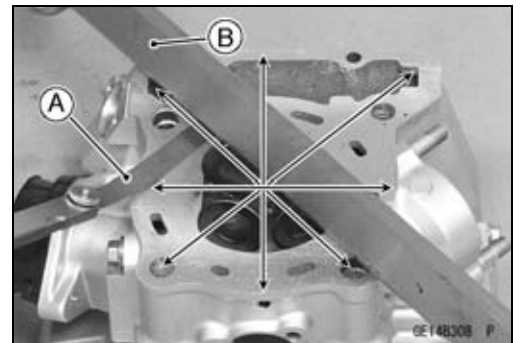
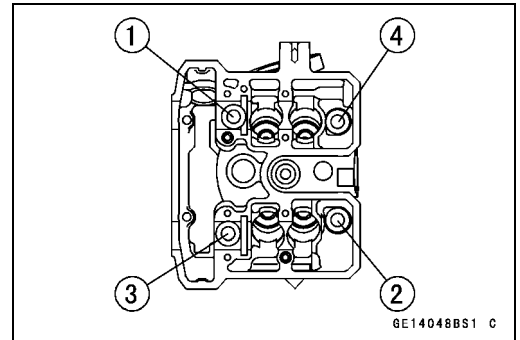

5-28 ENGINE TOP END

Valve

Valve Removal

- Remove the cylinder head.
- Remove the valve lifter and shim from the valve.
- Record the positions of the shims so they can be installed in their original positions.
- Compress the valve spring, and remove the split keeper.

Special Tools - Valve Spring Compressor Assembly: 57001-241 [A]

Valve Spring Compressor Adapter ϕ 24: 57001-1586 [B]

- Remove:
 - Spring Retainer
 - Outer Valve Spring
 - Inner Valve Spring
- Remove the valve.

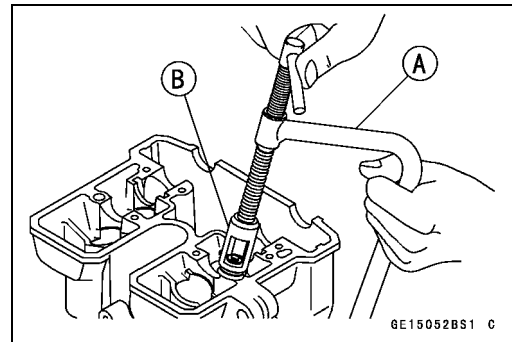

Valve Installation

- Replace the stem oil seal [C] with a new one.
- Apply molybdenum disulfide grease to the valve stem [A], and install it.
- Check the valve moves up and down smoothly.
- The inner valve spring [D] and the outer valve spring [E] should be installed with their tightly wound ends placed near the spring seats [B].
- Compress the valve springs and engage the split keeper [G] to fasten the spring retainer [F].

Special Tools - Valve Spring Compressor Assembly: 57001-241

Valve Spring Compressor Adapter, ϕ 24: 57001-1586

- Put on the shim [H] with a thickness indication facing the retainer.
- Replace the shim back to the position noted earlier and install it as it was.

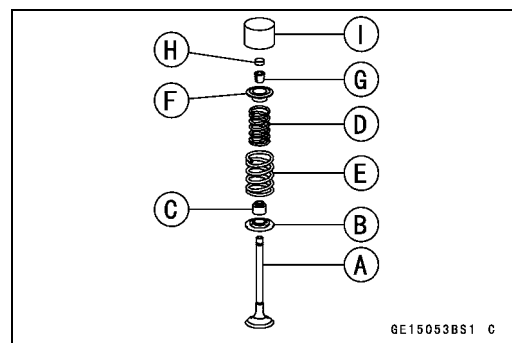

NOTE

○ Apply grease to the shim or the retainer to prevent the shim from falling off while installing the camshaft.

- Apply engine oil to the valve lifter [I] surface and install the lifter.

Valve Guide Removal

- Remove:
 - Valve
 - Stem Oil Seal
 - Spring Seats
- Heat the area around the valve guide to 120 ~ 150 °C, and hammer lightly on the valve guide arbor [A] to remove the guide from the top of the head.

Special Tool - Valve Guide Arbor, ϕ 4.5: 57001-1331

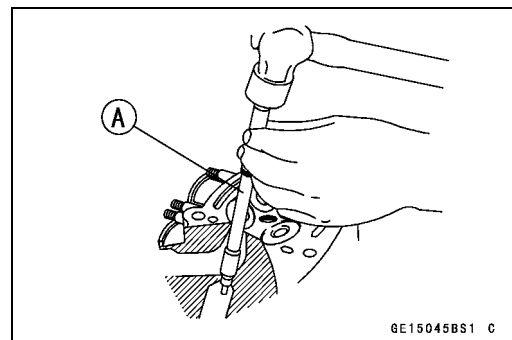

NOTICE

Do not heat the cylinder head with a torch. This will warp the cylinder head. Soak the cylinder head in engine oil and heat the oil.

Valve

Valve Guide Installation

- Apply a thin coat of oil to the outer surface of the valve guide.
- Heat the area around the valve guide up to 120 ~ 150°C (248 ~ 302°F).

NOTICE

Do not heat the cylinder head with a torch. This will warp the cylinder head. Soak the cylinder head and heat the oil.

- Using the valve guide driver [A] and attachment [B], press and insert the valve guide in until the attachment bottom surface touches the head surface [C].
15.3 ~ 15.5 mm (0.602 ~ 0.610 in.) [D]

Special Tools - Valve Guide Driver: 57001-1564

Valve Guide Driver Attachment F: 57001-1722

- Wait until the cylinder head cools down and then ream the valve guide with the valve guide reamer [A] even if the old guide is reused.
- Turn the reamer in a clockwise direction until the reamer turns freely in the guide. Never turn the reamer counter-clockwise or it will be dulled.
- Wash the guide thoroughly when its finish grinding is completed.

Special Tool - Valve Guide Reamer, ϕ 4.5: 57001-1333

Valve Guide Wear (Wobble Method)

- If a small bore gauge is not available, inspect the valve guide wear by measuring the valve-to-guide clearance with the wobble method as indicated below. The reading is not actual valve-to-guide clearance because the measuring point is above the guide.
- Insert a new valve [A] into the guide [B] and set a dial gauge against the stem perpendicular to it as close as possible to the cylinder head gasket surface.
- Move the stem back and forth [C] to measure valve-to-guide clearance.
- Repeat the measurement in a direction at a right angle (90°) to the first.
- ★ If the reading exceeds the service limit, replace the guide.

Valve/Valve Guide Clearance (Wobble Method)

Standard:

Exhaust	0.08 ~ 0.15 mm (0.0031 ~ 0.0059 in.)
Inlet	0.03 ~ 0.10 mm (0.0012 ~ 0.0039 in.)

Service Limit:

Exhaust	0.33 mm (0.013 in.)
Inlet	0.28 mm (0.011 in.)

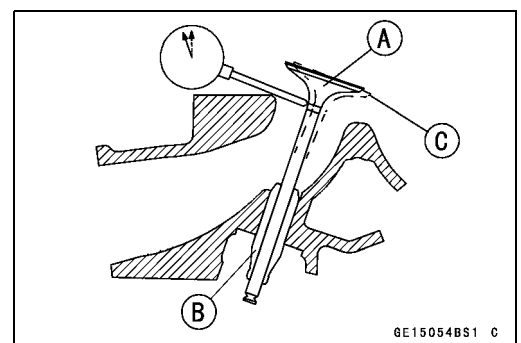
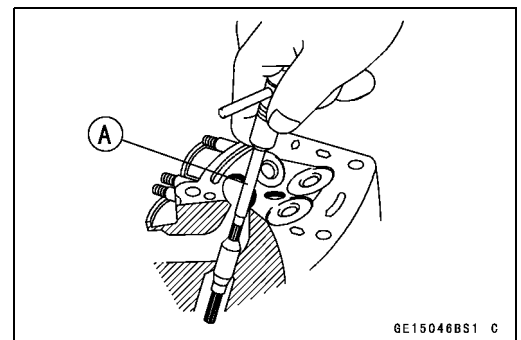
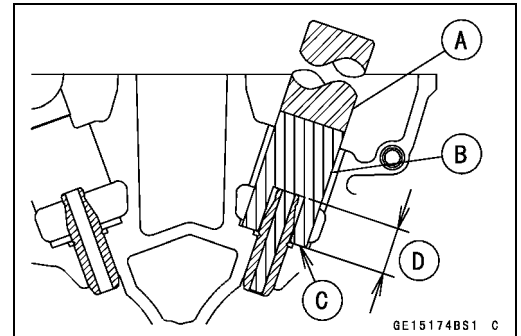

5-30 ENGINE TOP END

Valve

Valve Seat Inspection

- Remove the valve.
- Check the valve seat surface [A] between the valve [B] and valve seat [C].
- Measure the outside diameter [D] of the seating pattern on the valve seat with a pair of vernier caliper.
- ★ If the outside diameter is too large or too small, repair the seat.

Valve Seat Surface Outside Diameter (Seat O.D.)

Standard:

Exhaust 24.4 ~ 24.6 mm (0.961 ~ 0.968 in.)

Inlet 28.4 ~ 28.6 mm (1.118 ~ 1.126 in.)

- Measure the seat width [E] of the portion where there is no build-up carbon (white portion) of the valve seat with vernier calipers.

Good [F]

- ★ If the width is too wide [G], too narrow [H] or uneven [J], repair the seat.

Valve Seat Surface Width (or Seat Width)

Standard:

Exhaust 0.5 ~ 1.0 mm (0.02 ~ 0.04 in.)

Inlet 0.5 ~ 1.0 mm (0.02 ~ 0.04 in.)

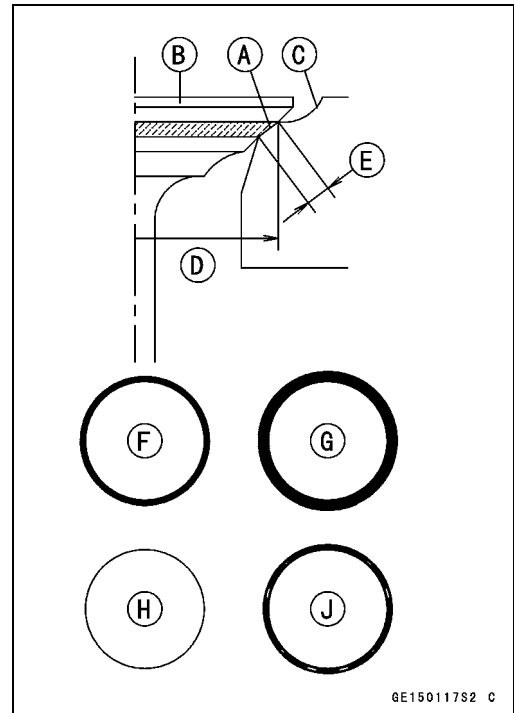

GE150117S2 C

Valve Seat Repair

- Repair the valve seat with the valve seat cutters [A].

Special Tools - Valve Seat Cutter Holder Bar: 57001-1128

[C]

Valve Seat Cutter Holder, $\phi 4.5$: 57001-1330

[B]

Exhaust Valve Seat

Valve Seat Cutter, 45° - $\phi 24.5$: 57001-1113

Valve Seat Cutter, 32° - $\phi 28$: 57001-1119

Valve Seat Cutter, 60° - $\phi 25$: 57001-1328

Inlet Valve Seat

Valve Seat Cutter, 45° - $\phi 27.5$: 57001-1114

Valve Seat Cutter, 32° - $\phi 30$: 57001-1120

Valve Seat Cutter, 60° - $\phi 30$: 57001-1123

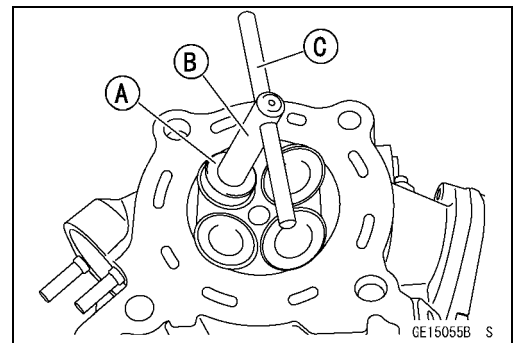

GE15055B S

○ The marks stamped on the back of the cutter [A] represent the following.

60° Cutter Angle [B]

37.5 ϕ Outer Diameter of Cutter [C]

- ★ If the manufacturer's instructions are not available, use the following procedure.

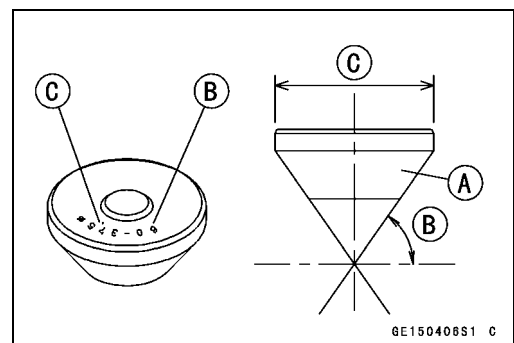

GE150408S1 C

Valve

Seat Cutter Operating Cares

1. This valve seat cutter is designed only for valve seat repair. Therefore the cutter must not be used for other purposes.
2. Do not drop or hit the valve seat cutter, or the diamond particles may fall off.
3. Do not fail to apply engine oil to the valve seat cutter before grinding the seat surface. Also wash off ground particles sticking to the cutter with washing oil.

NOTICE

Do not use a wire brush to remove the metal particles from the cutter. It will take off the diamond particles.

4. Setting the valve seat cutter holder into the valve guide, operate the cutter in one hand. Do not apply too much force to the diamond portion.

NOTE

○Prior to grinding, apply engine oil to the cutter. During operation, wash off any ground particles sticking to the cutter with washing oil.

5. After use wash the cutter with washing oil and apply a thin layer of engine oil before storing.

Operating Procedures

- Clean the seat area carefully.
- Coat the seat with machinist's dye.
- Fit a 45° cutter [A] into the holder [B] and slide it into the valve guide.
- Press down lightly on the handle and turn it right or left [C]. Grind the seat surface only until it is smooth.

NOTICE

Do not ground the seat longer than necessary. Excessive grinding will cause the valve to sink deeper in the head and necessitate a larger adjustment in valve clearance.

- Measure the outside diameter (O.D.) [A] of the seat surface (seat outer diameter) with vernier calipers.
- ★ If the seat O.D. is too small, repeat the 45° grind [B] until the diameter is within the specified range.
Ground Volum [C]

NOTE

- Remove all pittings or flaws from the ground surface.
- After grinding with a cutter, apply thin coat of machinist's dye to seating surface. This makes seat surface distinct and 32° and 60° grinding operation easier.
- When the valve guide is replaced, be sure to grind with 45° cutter for centering and good contact.

- ★ If the O.D. of the seating surface is too large, make the 32° grind described below.

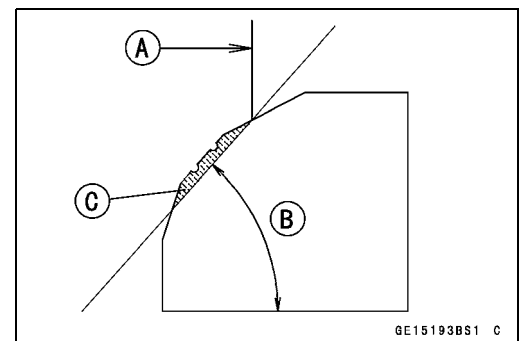
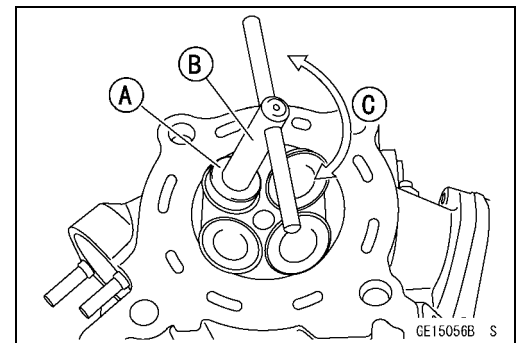

5-32 ENGINE TOP END

Valve

- To make the 32° grind, fit a 32° cutter into the holder, and slide it into the valve guide.
- Turn the holder one turn at a time while pressing down very lightly. Check the seat after each turn.

NOTICE

The 32° cutter removes material very quickly. Check the seat outside diameter frequently to prevent overgrinding.

- Grind the seat at a 32° angle [A] until the seat O.D. [B] is within the specified range.
- ★ If the O.D. of the seating surface is within the specified range, measure the seat width as described below.
- To measure the seat width, use vernier calipers to measure the width [C] of the 45° angle portion of the seat at several places around the seat.
Ground Voluum [D]
- ★ If the seat width is too narrow, repeat the 45° grind until the seat is slightly too wide, and then measure the seat O.D..
- ★ If the seat width is too wide, make the 60° grind described below.
- To make the 60° grind, fit a 60° cutter into the holder, and slide it into the valve guide.
- Turn the holder, while pressing down lightly.
- Grind the seat at a 60° angle [A] until the seat width [B] is within the specified range.

- Lap the valve to the seat, once the seat width and outside diameter are within the ranges specified above.
- Put a little coarse grinding compound on the face of the valve in a number of places around the valve head.
- Spin the valve against the seat until the grinding compound produces a smooth, matched surface on both the seat and the valve.
- Repeat the process with a fine grinding compound.

Lapper [A]
Valve Seat [B]
Valve [C]

- The seat area should be marked about in the middle of the valve face.
- ★ If the seat area is not in the right place on the valve, check to be sure the valve is the correct part. If it is, it may have been refused too much; replace it.
- Be sure to remove all grinding compound before assembly.

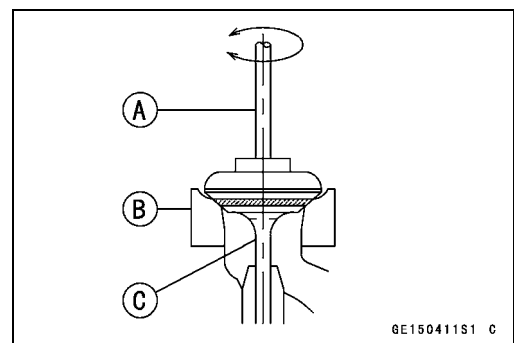
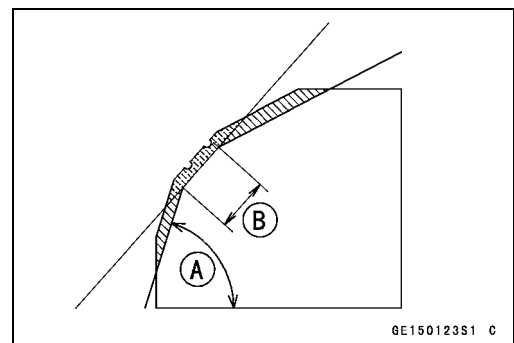
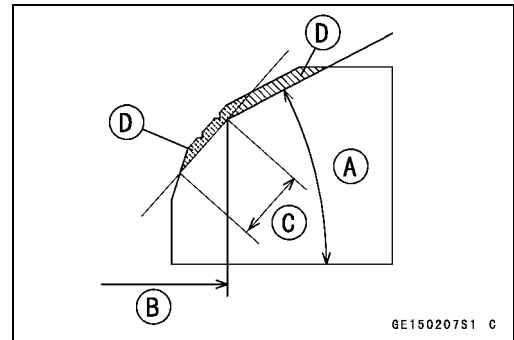

Valve

Valve Seat Repair

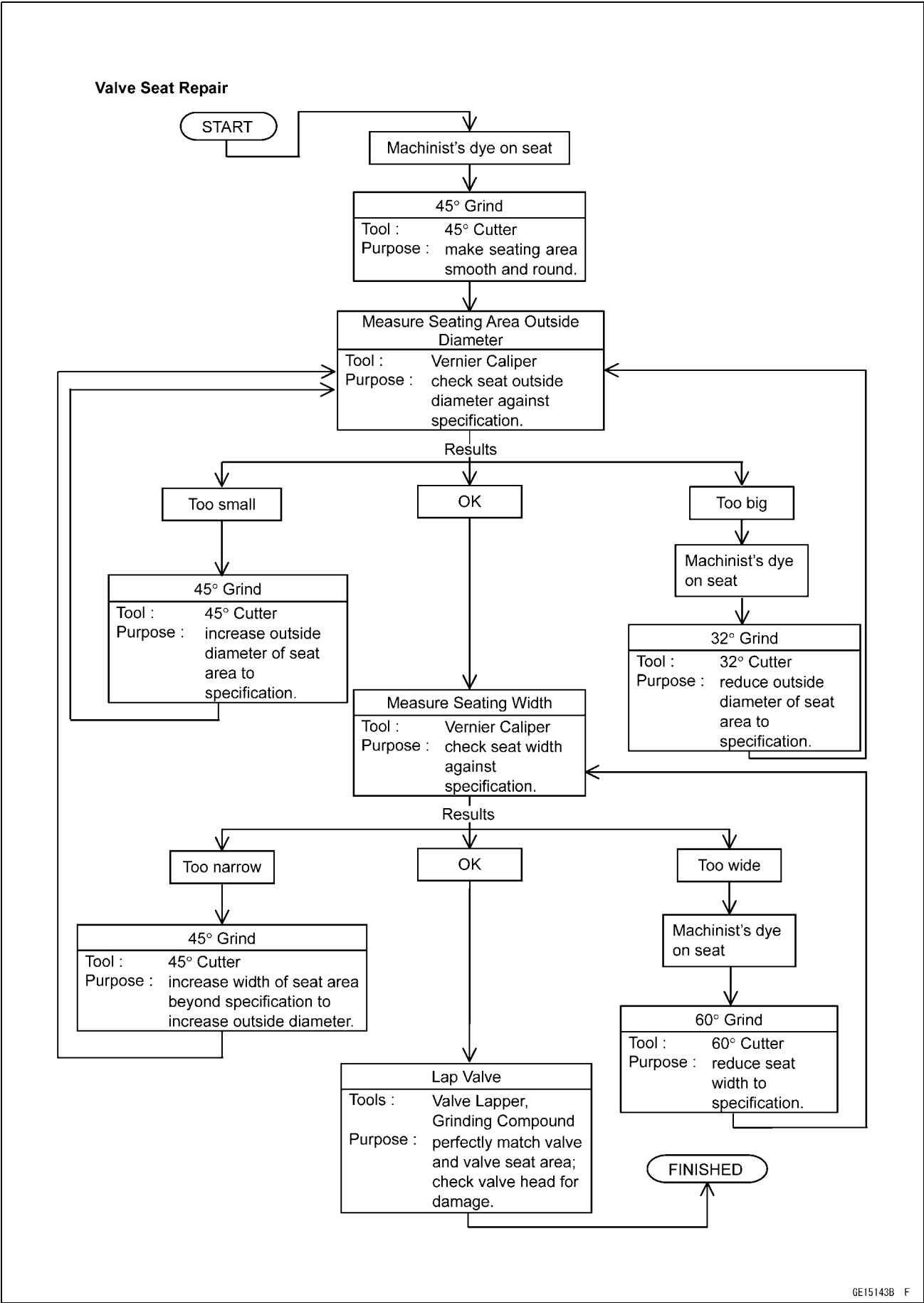

5-34 ENGINE TOP END

Cylinder, Piston

Cylinder Removal

- Remove:
 - Cylinder Head (see Cylinder Head Removal)
 - Radiator Hose Fitting Bolts [A]
 - Radiator Hose Fitting [B]

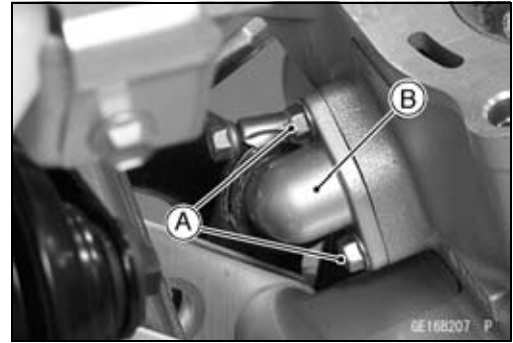

- Remove the cylinder [A] and cylinder base gasket.

NOTE

○ If it is hard to remove it, tap lightly using a plastic-faced mallet [B].

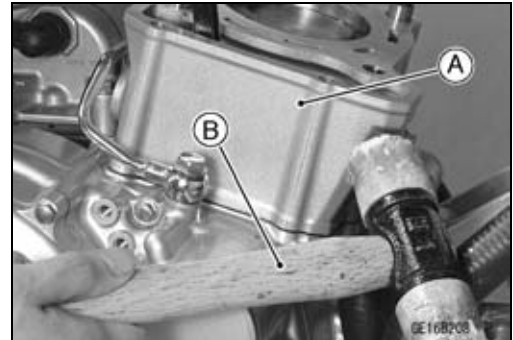

Piston Removal

- Remove the cylinder (see Cylinder Removal).
- Remove the piston pin snap ring [A].

NOTE

○ Stuff a clean cloth [B] into the crankcase opening to keep any parts from dropping into the crankcase.



- Using the piston pin puller Assy, remove the piston pin.
Special Tool - Piston Pin Puller Assembly [A]: 57001-910
- Remove the piston.



- Carefully spread the ring [A] opening with your fingers and then push up on the opposite side of the ring to remove it.
- Similarly, disengage a set of three oil rings.



Cylinder, Piston

Cylinder, Piston Installation

NOTE

○The oil ring rails have no “top” or “bottom”.

- Install the oil ring expander [A] in the bottom piston ring groove so the ends [B] butt together.
- Install the oil ring steel rails, one above the expander and one below it.
- Spread the rail with your thumbs, but only enough to fit the rail over the piston.
- Release the rail into the bottom piston ring groove.
- Do not mix up the top and second rings.
- The top ring has a whitish finished surface, while the second ring has a blackish finished surface.
- Install the top ring [A] so that the “R” mark [B] faces up.
- Install the second ring [C] so that the “R” mark [D] face up.

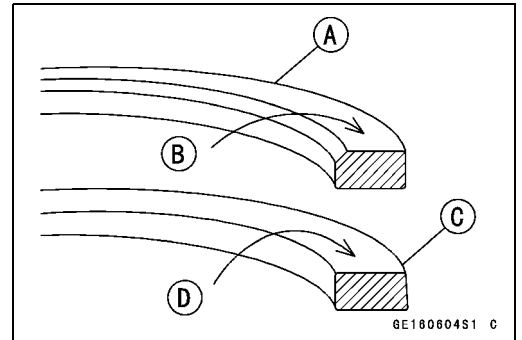
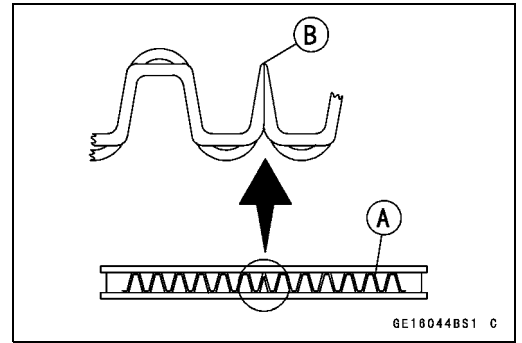

NOTE

○The piston-to-cylinder clearance is measured whenever a piston or cylinder is replaced with a new one. Also use new piston rings.

- Apply engine oil to the inside of the connecting rod small end.
- Install the piston with the Δ mark [A] provided on the head facing forward [B].
- Install the piston pin and piston ring.

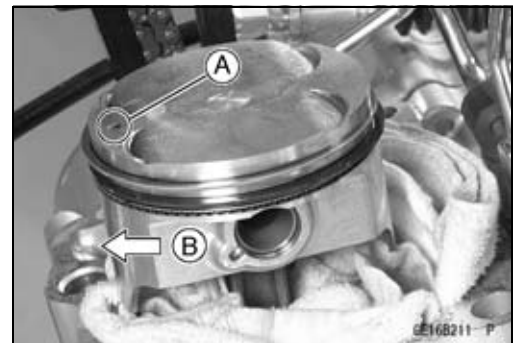

NOTICE

Always replace the piston pin snap ring with a new one.
When installing a snap ring, compress it only enough to install it and no more.
Fit a new piston pin snap ring into the side of the piston so that the ring opening [A] does not coincide with the notch [B] in the edge of the piston pin hole.

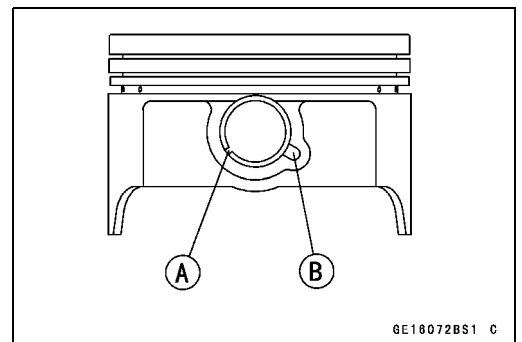

- The piston ring openings must be positioned as shown in the figure. The openings of the oil ring steel rails must be about 30 ~ 45° [F] of angle from the opening of the top ring.

- Top Ring [A]
- Second Ring [B]
- Oil Ring Steel Rails [C]
- Oil Ring Expander [D]
- The Δ mark [E] should face the front side of the engine.
- The end-gap positions [G] of the rings are shown.

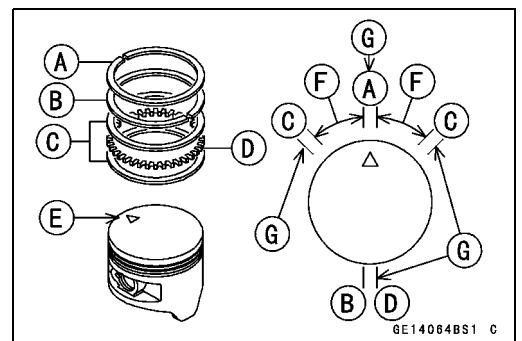

5-36 ENGINE TOP END

Cylinder, Piston

- Apply liquid gasket to the upper surface [A] of the crankcase mating surface.
[B] about 10 mm (0.39 in.)

Sealant - Liquid Gasket, TB1216B: 92104-1064

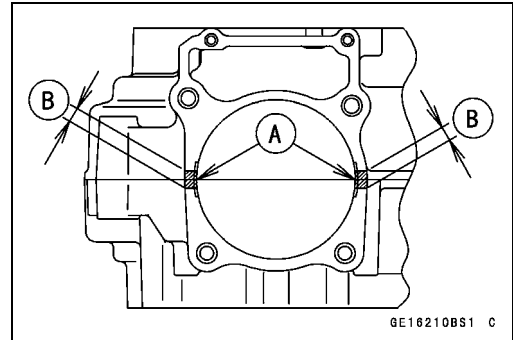

- Install the dowel pins [A].
- Replace the cylinder base gasket [B] with a new one.

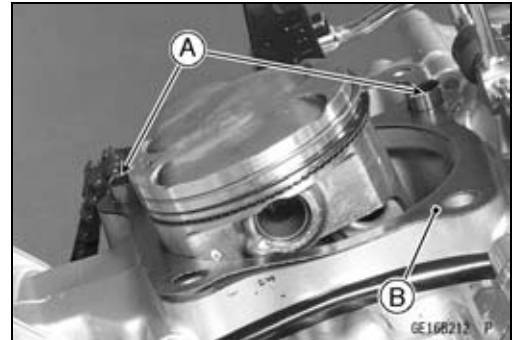

- Compress the piston ring with fingers or a tool to fit the piston into the cylinder.

Special Tools - Piston Ring Compressor Grip: 57001-1095 [A]

Piston Ring Compressor Belt, $\phi 67 \sim \phi 79$: 57001-1097 [B]

- Make chamfer side of the compressor belt faces upwards.
- Install removed parts (see appropriate chapters).

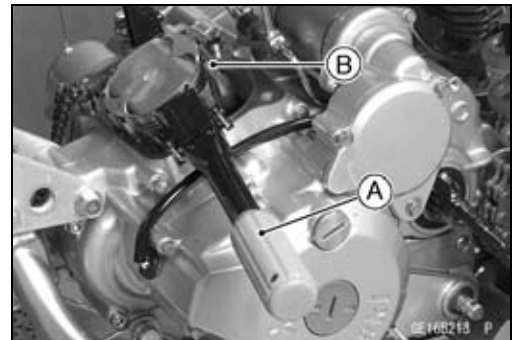

Cylinder Wear

- Since there is a difference in cylinder wear in different directions, take a side-to-side and a front-to-back measurement at each of the three locations (total of six measurements) shown in the figure.

10 mm (0.4 in.) [A]

50 mm (2.0 in.) [B]

20 mm (0.8 in.) [C]

Cylinder Inside Diameter

Standard: 72.000 ~72.012 mm (2.8346 ~ 2.8351 in.), while differences in measurements should be within 0.01 mm (0.0004 in.).

Service Limit: 72.07 mm (2.837 in.), or differences in measurements should be within 0.05 mm (0.0020 in.).

- ★ If any of the cylinder inside diameter measurements exceeds the service limit, replace the cylinder.

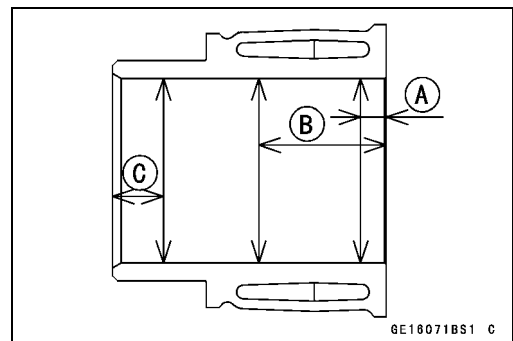

Cylinder, Piston

Piston Wear

- Measure the outside diameter [A] of each piston 5 mm [B] up from the bottom of the piston at a right angle to the direction of the piston pin.

Piston Diameter

Standard: 71.950 ~ 71.965 mm (2.8327 ~ 2.8333 in.)

Service Limit: 71.80 mm (2.827 in.)

- ★ If the measurement is under the service limit, replace the piston.

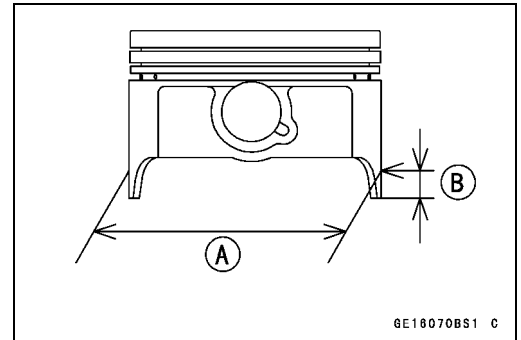

Piston/Cylinder Clearance

- Subtract the piston diameter from the cylinder inside diameter to get the piston/cylinder clearance.

Piston/Cylinder Clearance

Standard: 0.035 ~ 0.062 mm (0.0014 ~ 0.0024 in.)

- ★ If the piston/cylinder clearance is less than the specified range, use a smaller piston made within the standard diameter or increase the cylinder inside diameter within the standard diameter by honing.
- ★ If the piston/cylinder clearance is greater than the specified range, use a larger piston made within the standard diameter.
- ★ If only a piston is replaced, the clearance may exceed the standard slightly. But it must not be less than the minimum, in order to avoid piston seizure.

Piston Ring, Piston Ring Groove Wear

- Visually inspect the piston rings and the ring grooves.
- ★ If the piston ring or the ring groove is distorted, unevenly worn or damaged, change pistons and piston rings.
- With the piston ring in its groove, make several measurements with a thickness gauge [A] to determine piston ring/groove clearance.

Piston Ring/groove Clearance:

Standard:

Top 0.03 ~ 0.07 mm (0.001 ~ 0.003 in.)

Second 0.03 ~ 0.07 mm (0.001 ~ 0.003 in.)

Service Limit:

Top 0.17 mm (0.0067 in.)

Second 0.17 mm (0.0067 in.)

- ★ If the piston ring groove clearance is greater than the service limit, measure the ring thickness and groove width to decide whether to replace the rings, the piston or both.

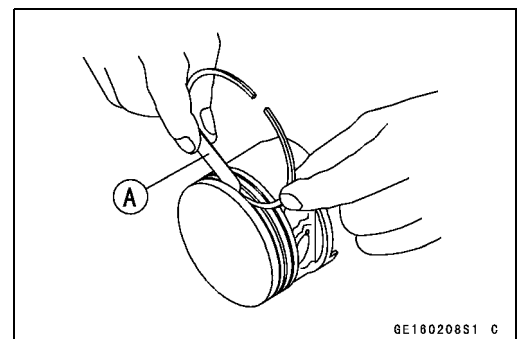

5-38 ENGINE TOP END

Cylinder, Piston

Piston Ring Groove Width

- Measure the width of the top ring [A], second ring [B] and oil ring [C] grooves.
- Use vernier calipers at several points around the piston.

Piston Ring Groove Width

Standard:

Top	1.02 ~ 1.04 mm (0.0402 ~ 0.0409 in.)
Second	1.02 ~ 1.04 mm (0.0402 ~ 0.0409 in.)
Oil	2.01 ~ 2.03 mm (0.0791 ~ 0.0799 in.)

Service Limit:

Top	1.12 mm (0.0441 in.)
Second	1.12 mm (0.0441 in.)
Oil	2.11 mm (0.0831 in.)

- ★ If the groove width exceeds the service limit, replace the piston.

Piston Ring Thickness

- Measure the thickness of the top [A] and second [B] rings.
- Use a micrometer to measure at several points around the rings.

Piston Ring Thickness

Standard:

Top	0.97 ~ 0.99 mm (0.038 ~ 0.039 in.)
Second	0.97 ~ 0.99 mm (0.038 ~ 0.039 in.)

Service Limit:

Top	0.90 mm (0.035 in.)
Second	0.90 mm (0.035 in.)

- ★ If any of the measurements is less than the service limit on either of the rings, replace all the rings.

NOTE

- When using new rings in a used piston, check for uneven groove wear. A ring must fit tightly along the top and bottom edges of the groove. If not, replace the piston.

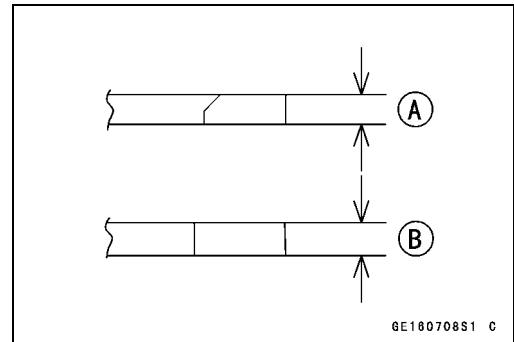
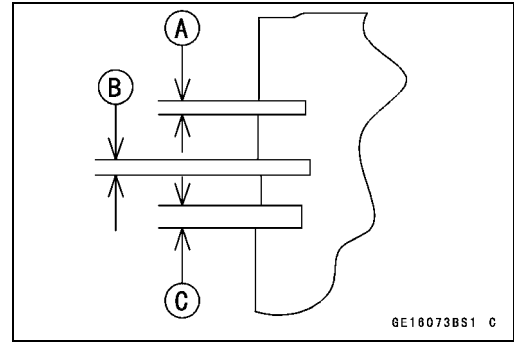

Cylinder, Piston

Piston Ring End Gap

- Place the piston ring [A] inside the cylinder, using the piston to locate the ring squarely in place. Set it close to the bottom of the cylinder, where cylinder wear is low.
- Measure the gap [B] between the ends of the ring with a thickness gauge.

Piston Ring End Gap

Standard:

Top	0.20 ~ 0.35 mm (0.0079 ~ 0.014 in.)
Second	0.20 ~ 0.35 mm (0.0079 ~ 0.014 in.)
Oil	0.20 ~ 0.70 mm (0.0079 ~ 0.028 in.)

Service Limit:

Top	0.6 mm (0.02 in.)
Second	0.6 mm (0.02 in.)
Oil	1.0 mm (0.039 in.)

- ★ If the end gap of any ring is greater than the service limit, replace the ring.

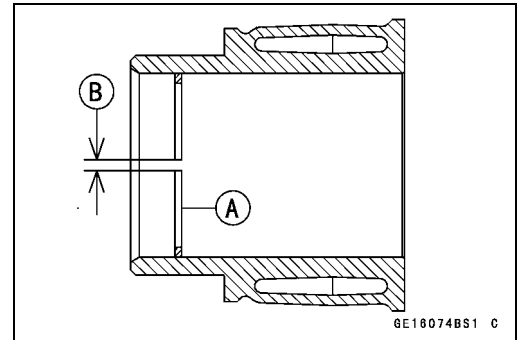

5-40 ENGINE TOP END

Throttle Body Assy Holder

Throttle Body Assy Holder Removal

- Remove:
 - Throttle Body Assy (see Throttle Body Assy Removal in the Fuel System (DFI) chapter)
 - Throttle Body Assy Holder Bolts [A]
 - Throttle Body Assy Holder [B]

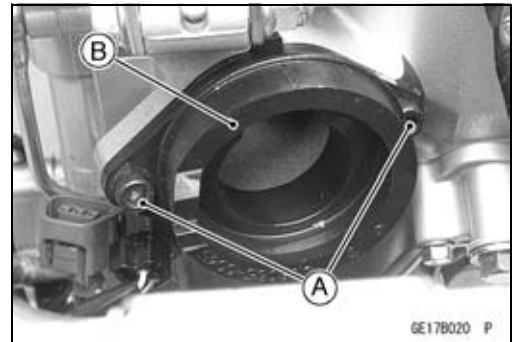

Throttle Body Assy Holder Installation

- Replace the O-ring [A] with a new one.
 - Apply grease to the O-ring.
 - Install the O-ring to the throttle body assy holder [B].
-
- Install the throttle body assy holder [B] so that the groove [A] faces left side.
 - Tighten:
 - Torque - Throttle Body Assy Holder Bolts [C]: 12 N·m (1.2 kgf·m, 106 in·lb)**

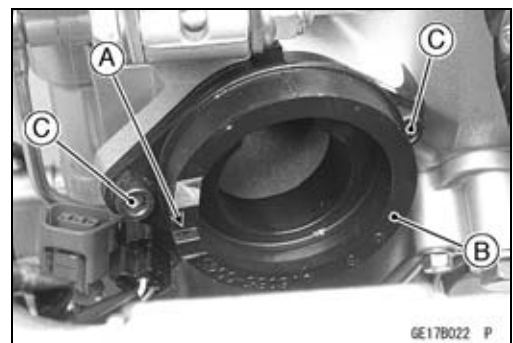
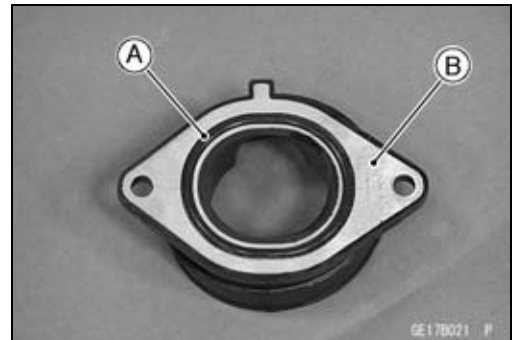

Mufflers

Muffler Body Removal

⚠ WARNING

The exhaust pipe or muffler body can become extremely hot during normal operation and cause severe burns. Do not remove the exhaust pipe or muffler body while it is hot.

- Remove:
 - Seat (see Seat Removal in the Frame chapter)
 - Oxygen Sensor Connector [A]
- Pull out the turn signal relay [B] from frame bracket.
- Pull the oxygen sensor lead to outside of frame.

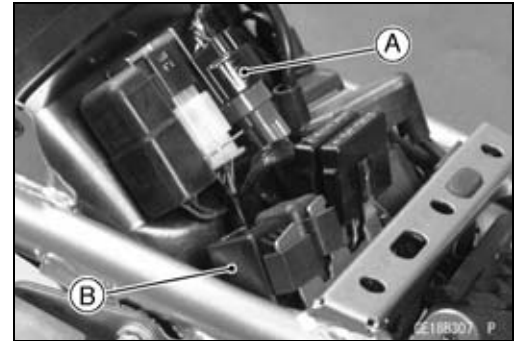

- Loosen the muffler clamp bolt [A].
- Remove:
 - Muffler Cover Bolt [B]
 - Muffler Cover [C]
 - Muffler Body Bolts [D]
 - Muffler Body Bolt and Nut [E]
- Removal the muffler body [F] backward.

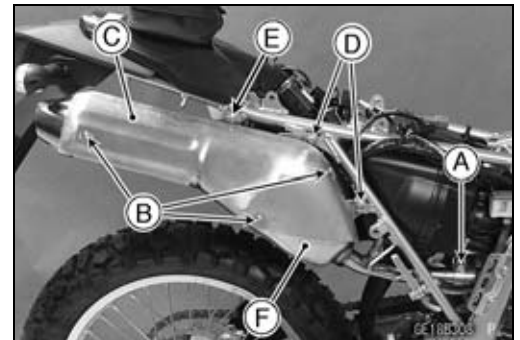

Muffler Body Installation

- Replace the muffler gasket [A] with a new one, and install it.
- Install the muffler body [B].

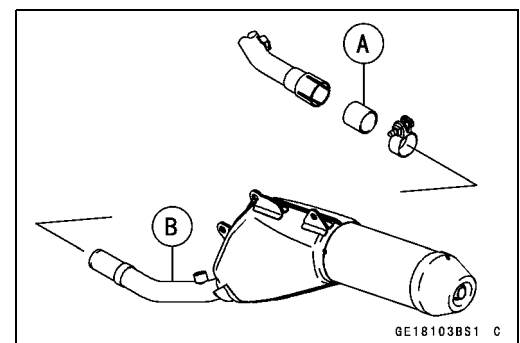

- Tighten:
 - Torque - Muffler Body Bolts (Front and Center) [A]: 30 N·m (3.0 kgf·m, 22 ft·lb)**
- First, tighten the muffler body bolt (rear) [B], and next tighten the muffler body nut [C].
 - Torque - Muffler Body Bolt (Rear): 9.8 N·m (1.0 kgf·m, 87 in·lb)**
 - Muffler Body Nut: 30 N·m (3.0 kgf·m, 22 ft·lb)**

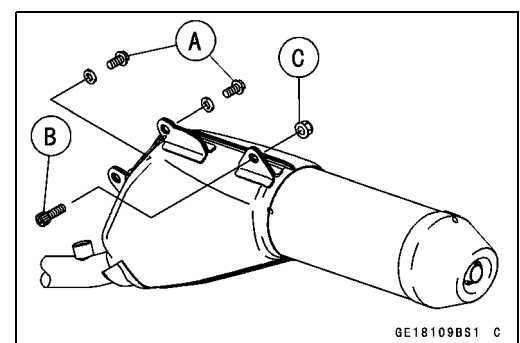

5-42 ENGINE TOP END

Mufflers

- Face the clamp bolt [B] on the muffler clamp [A], and position the clamp between the slits [C] on the exhaust pipe [D].

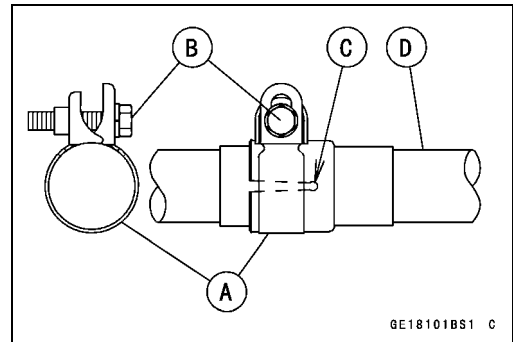

- Install the muffler clamp [A] as shown, and tighten the clamp bolt securely.
20 ~ 40° [B]

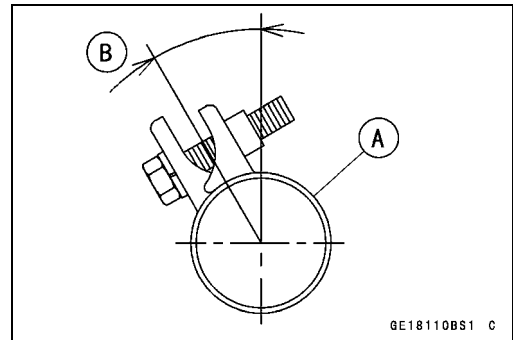

- Apply a molybdenum disulfide grease to lower muffler cover bolts [A].
- Tighten:
Torque - Muffler Cover Bolts: 9.8 N·m (1.0 kgf·m, 87 in·lb)
- After the engine is enough warm up, wait the cool down and tighten more the muffler clamp bolt, muffler body bolts and exhaust pipe holder nut.



Exhaust Pipe Removal

- Remove:
Muffler Body (see Muffler Body Removal)
Exhaust Pipe Holder Nuts [A]
Exhaust Pipe [B]

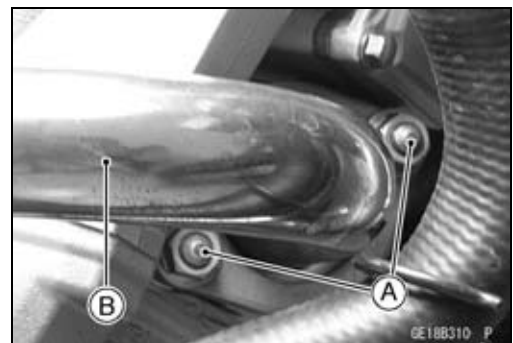

Exhaust Pipe Installation

- Replace the exhaust pipe gasket with a new one.
- Install the exhaust pipe.
- Tighten the exhaust pipe holder nuts.
- Install the muffler body (see Muffler Body Installation).

Clutch

Table of Contents

Exploded View	6-2
Specifications	6-4
Special Tool	6-5
Clutch Lever and Cable	6-6
Clutch Lever Free Play Inspection	6-6
Clutch Lever Free Play Adjustment	6-6
Clutch Cable Removal	6-6
Clutch Cable Installation	6-6
Clutch Cable Lubrication	6-6
Clutch Lever Installation	6-6
Clutch Cover and Right Engine Cover	6-7
Clutch Cover Removal	6-7
Clutch Cover Installation	6-7
Right Engine Cover Removal	6-7
Right Engine Cover Installation	6-8
Clutch	6-10
Clutch Removal	6-10
Clutch Installation	6-10
Clutch Plate Assy Disassembly	6-11
Clutch Plate Assy Assembly	6-11
Clutch Plate Assy Inspection and Adjustment	6-12
Friction and Steel Plates Wear, Damage Inspection	6-13
Friction and Steel Plates Warp	6-13
Clutch Spring Free Length Inspection	6-13
Clutch Housing Groove Inspection	6-14
Clutch Hub Spline Inspection	6-14

6-2 CLUTCH

Exploded View

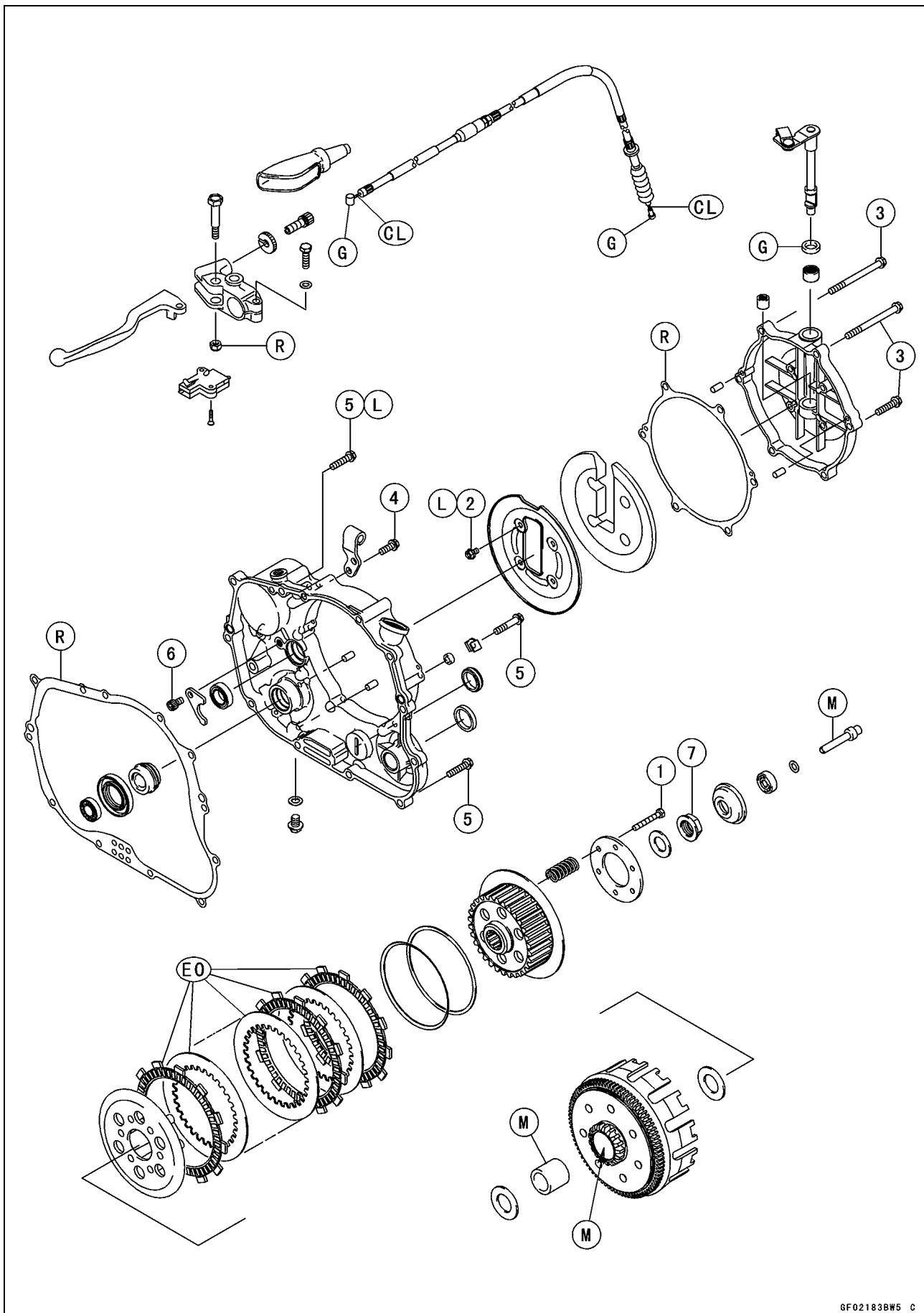

Exploded View

No.	Fastener	Torque			Remarks
		N·m	kgf·m	ft·lb	
1	Clutch Spring Bolts	7.8	0.80	69 in·lb	
2	Clutch Cover Damper Plate Bolts	7.8	0.80	69 in·lb	L
3	Clutch Cover Bolts	9.8	1.0	87 in·lb	
4	Clutch Cable Holder Bracket Bolts	9.8	1.0	87 in·lb	
5	Right Engine Cover Bolts	9.8	1.0	87 in·lb	L (1)
6	Oil Seal Retaining Plate Bolt	12	1.2	106 in·lb	
7	Clutch Hub Nut	78	8.0	58	

CL: Apply cable lubricant.

EO: Apply engine oil.

G: Apply grease.

L: Apply a non-permanent locking agent.

M: Apply molybdenum disulfide grease.

R: Replacement Parts

6-4 CLUTCH

Specifications

Item	Standard	Service Limit
Clutch Lever		
Clutch Lever Play	2 ~ 3 mm (0.08 ~ 0.12 in.)	— — —
Clutch		
Plate Assy Thickness	30.3 ~ 30.9 mm (1.19 ~ 1.22 in.)	— — —
Clutch Spring Free Length	35.4 mm (1.39 in.)	33.9 mm (1.33 in.)
Friction Plate Thickness	2.92 ~ 3.08 mm (0.115 ~ 0.121 in.)	2.7 mm (0.11 in.)
Friction Plate/Clutch Housing Clearance	0.09 ~ 0.70 mm (0.0035 ~ 0.028 in.)	0.95 mm (0.037 in.)
Friction Plate Warp	0.15 mm (0.0060 in.) or less	0.3 mm (0.01 in.)
Steel Plate Warp	0.20 mm (0.0079 in.) or less	0.3 mm (0.01 in.)

Special Tool

**Gear Holder:
57001-1602**

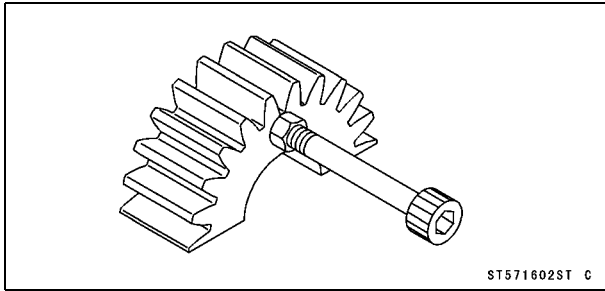

6-6 CLUTCH

Clutch Lever and Cable

Clutch Lever Free Play Inspection

- Refer to the Clutch Operation Inspection in the Periodic Maintenance chapter.

Clutch Lever Free Play Adjustment

- Refer to the Clutch Operation Inspection in the Periodic Maintenance chapter.

Clutch Cable Removal

- Slide the dust cover [A] at the middle of the clutch cable.
- Loosen the locknut [B] and turn the adjusting nut [C] to give the cable plenty of play.

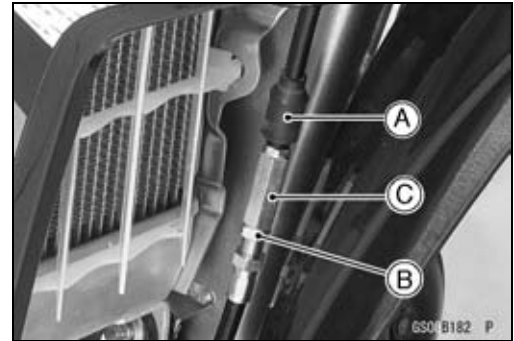

- Loosen the locknut [A].
- Line up the slots [B] in the clutch lever and adjuster [C], and then free the cable from the lever.
- Free the clutch inner cable tip from the clutch release lever.
- Push the release lever toward the front of the motorcycle and tape the release lever to the clutch cover to prevent the release shaft from falling out.
- Pull the clutch cable out of the frame.

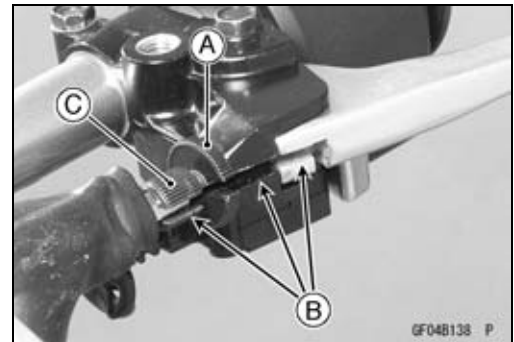

Clutch Cable Installation

- Run the clutch cable correctly (see Cable, Wire, and Hose Routing section in the Appendix chapter).
- Adjust the clutch cable (see Clutch Operation Inspection in the Periodic Maintenance chapter).

Clutch Cable Lubrication

- Refer to the Chassis Parts Lubrication in the Periodic Maintenance chapter.

Clutch Lever Installation

- Install the clutch lever so that the slit [A] of the clutch lever clamp is aligned with the punch mark [B].
- Tighten the clutch lever clamp bolt [C] securely.

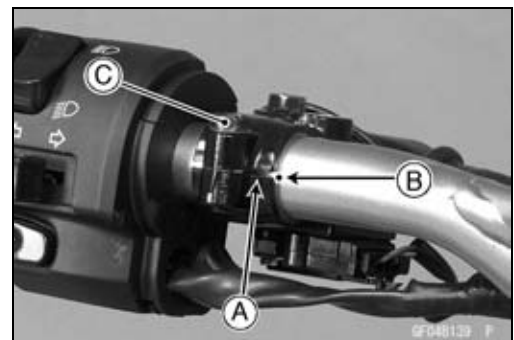

Clutch Cover and Right Engine Cover

Clutch Cover Removal

- Drain the engine oil (see Engine Oil Change in the Periodic Maintenance chapter).
- Remove:
 - Clutch Cable Lower End (see Clutch Cable Removal)
 - Clutch Cover Bolts [A]
 - Clutch Cover [B]

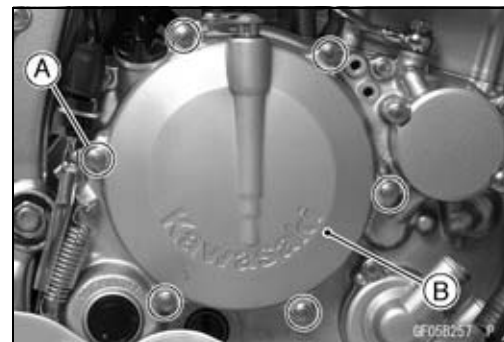

NOTICE

Do not remove the clutch release shaft [A] unless it is absolutely necessary. If removed, the oil seal [B] replacement may be required.

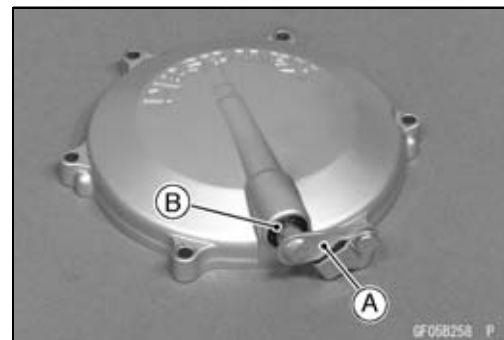

Clutch Cover Installation

- Make sure the two dowel pins [A] are in position.
- Turn the clutch release lever toward the rear.
- Replace the clutch cover gasket [B] with a new one.
- Install the clutch cover.

Torque - Clutch Cover Bolts: 9.8 N·m (1.0 kgf·m, 87 in·lb)

Clutch Cable Holder Bracket Bolts: 9.8 N·m (1.0 kgf·m, 87 in·lb)

- After installing the clutch cable, adjust its free play (see Clutch Operation Inspection in the Periodic Maintenance chapter).



Right Engine Cover Removal

- Drain the engine oil (see Engine Oil Change in the Periodic Maintenance chapter).
- Drain the coolant (see Coolant Change in the Periodic Maintenance chapter).
- Remove:
 - Water Pump (see Water Pump Removal in the Cooling System chapter)
 - Clutch Cable Lower End (see Clutch Cable Removal)
 - Brake Pedal (see Brake Pedal Removal in the Brakes chapter)

6-8 CLUTCH

Clutch Cover and Right Engine Cover

- Remove the rear brake light switch bracket bolt [A] to free the brake light switch.

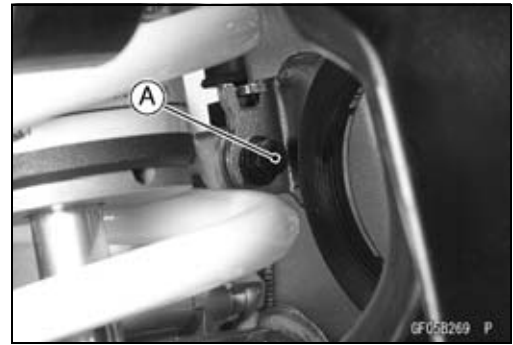

- Remove:
 - Right Front Footpeg Bolt [A]
 - Right Front Footpeg Nut [B]
 - Right Front Footpeg [C]

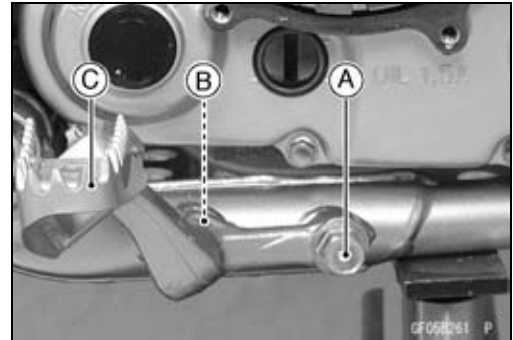

- Remove:
 - Oil Pipe Banjo Bolt [A]
- Remove the right engine cover bolts [B] and take off the right engine cover [C] with the clutch cover installed.

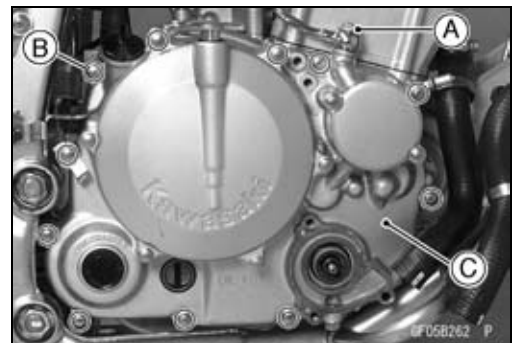

Right Engine Cover Installation

- Make sure the O-ring [A] is chamfered side facing outward.



- Make sure the two dowel pins [A] are in position.
- Turn the clutch release lever toward the rear.
- Replace the right engine cover gasket [B] with a new one.

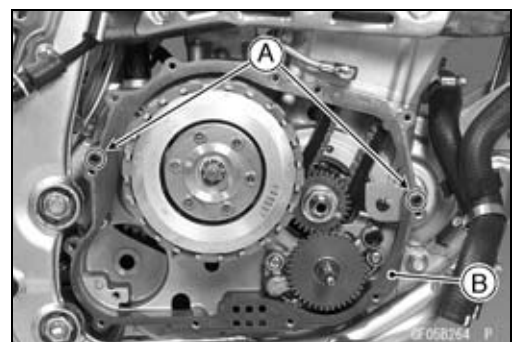

Clutch Cover and Right Engine Cover

- Apply a non permanent locking agent to the thread of the right engine cover bolt [A].
- Install the right engine cover.

Torque - Right Engine Cover Bolts [A] [B]: 9.8 N·m (1.0 kgf·m, 87 in·lb)

- Install the water pump (see Water Pump Installation in the Cooling System chapter).
- Replace the oil pipe banjo bolt washers with new ones, and tighten the oil pipe banjo bolt [C].

Torque - Oil Pipe Banjo Bolt (M10): 20 N·m (2.0 kgf·m, 15 ft·lb)

- Install:
 - Brake Pedal (see Brake Pedal Installation in the Brakes chapter)
 - Right Front Footpeg
- Fill the coolant (see Coolant Change in the Periodic Maintenance chapter).
- Fill the engine oil (see Engine Oil Change in the Periodic Maintenance chapter).
- Adjust the clutch lever free play (see Clutch Operation Inspection in the Periodic Maintenance chapter).
- Check the rear brake (see Brake Operation Inspection in the Periodic Maintenance chapter).

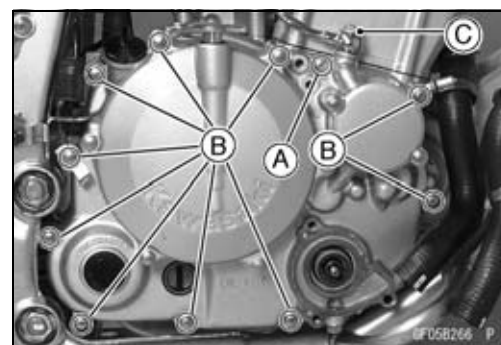

6-10 CLUTCH

Clutch

Clutch Removal

- Drain the engine oil (see Engine Oil Change in the Periodic Maintenance chapter).
- Remove:
 - Right Engine Cover (see Right Engine Cover Removal).
 - Oil Pump (see Oil Pump Removal in the Engine Lubrication System chapter).
- Remove:
 - Clutch Pusher [A]
 - Washer [B]
 - Holder [C]

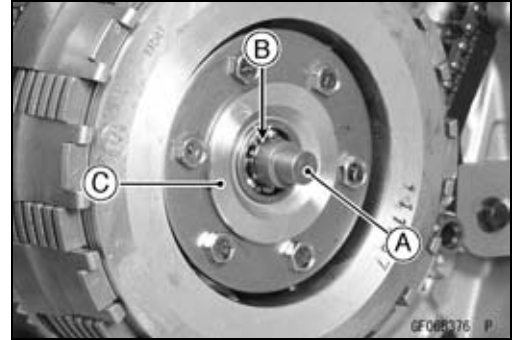

- Using the gear holder [A] to prevent the clutch from rotating.

Special Tool - Gear Holder: 57001-1602

- Remove:
 - Clutch Hub Nut [B] and Washer
 - Clutch Plate Assy [C] and Washer
 - Clutch Housing [D]

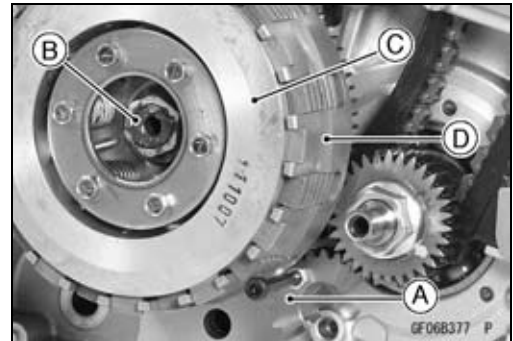

- Remove:
 - Sleeve [A]
 - Washer [B]

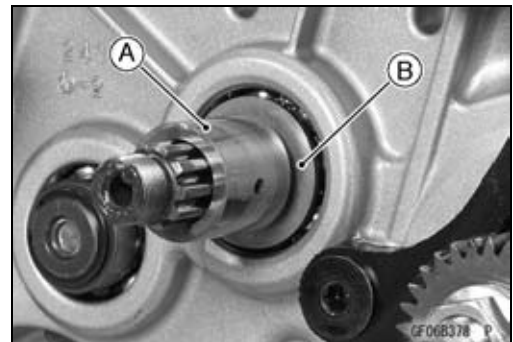

Clutch Installation

- Install:
 - Washer [A]

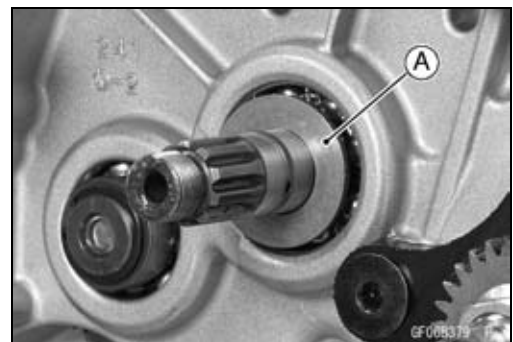

Clutch

- Apply molybdenum disulfide grease to the sleeve and inside of the clutch housing boss.
- Install the sleeve [A] into the clutch housing [B].
- Install:
Clutch Housing with the sleeve installed
Washer [C]



- Install the clutch plate assy [A].
- Install the last friction plate [B] in the shallower groove in the clutch housing.
- Using the gear holder [C] to prevent the clutch from rotating.

Special Tool - Gear Holder: 57001-1602

- Tighten:
Torque - Clutch Hub Nut [D]: 78 N·m (8.0 kgf·m, 58 ft·lb)

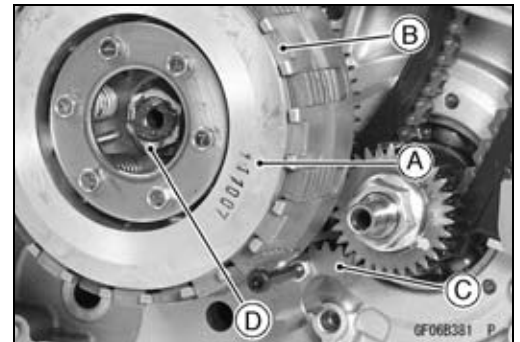

- Apply molybdenum disulfide grease to the clutch pusher [A].
- Install:
Holder [B]
Washer [C]
Clutch Pusher
- Install removed parts (see appropriate chapters).

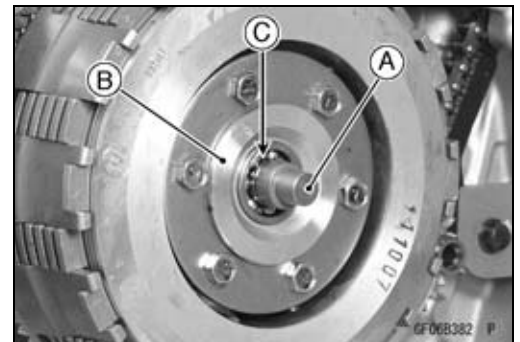

Clutch Plate Assy Disassembly

- Remove:
Spring Bolts [A]
Spring Plate [B]
Springs [C]
Clutch Wheel [D]
Judder Spring Seat
Judder Spring
Friction Plate
Steel Plates

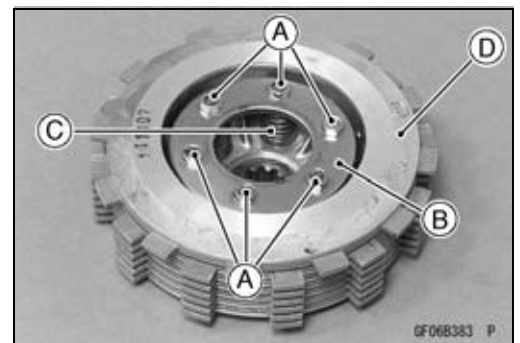

Clutch Plate Assy Assembly

- Install the judder spring seat [A] and judder spring [B] to the clutch hub [C] as shown.
- Apply engine oil to the friction and steel plates.

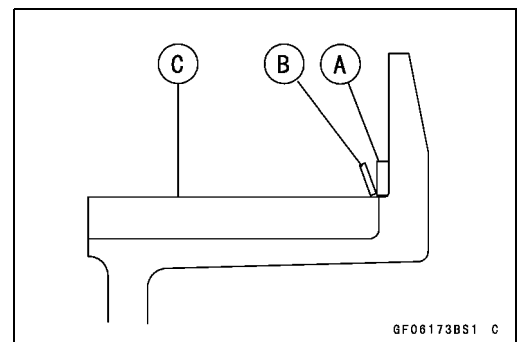

6-12 CLUTCH

Clutch

- Assemble the friction plate and the clutch plate to the clutch hub.
- First, install the friction plate [A] and steel plate (without knurling) [B].
- Then install the friction plates [C] and steel plates [D] (with knurling), starting with a friction plate and alternating them.
- Turn the outside friction plate to shift its phase by 15°.
- Install the clutch wheel [E].

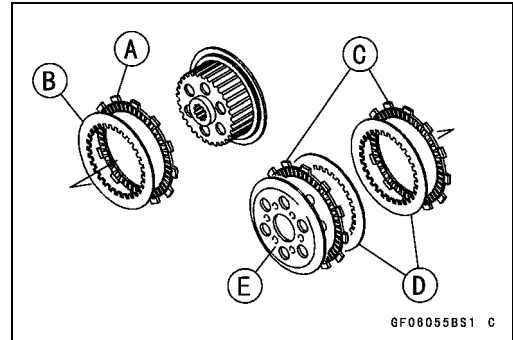

NOTICE

If new dry steel plates or friction plates are installed, apply engine oil to the surface of each plate to avoid clutch plate seizure.

- Install:
 - Springs [A]
 - Spring Plate [B]
 - Spring Bolts [C]
- Torque - Clutch Spring Bolts: 7.8 N·m (0.80 kgf·m, 69 in·lb)**
- Check the plate assy thickness (see Plate Assy Thickness Inspection and Adjustment).

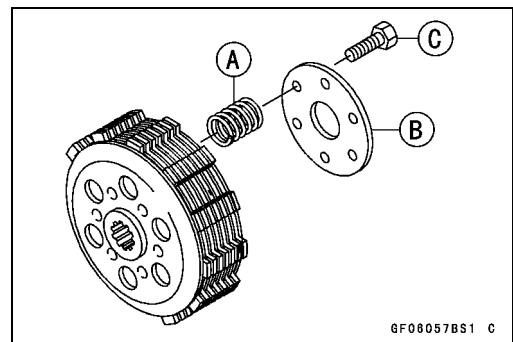

Clutch Plate Assy Inspection and Adjustment

- Measure the thickness [A] of the clutch plate assy.
- Clutch Plate Assy Thickness**
Standard: 30.3 ~ 30.9 mm (1.19 ~ 1.22 in.)
- ★ If the thickness is not in the standard range, change steel plates to adjust thickness.
- Remove:
 - Spring Bolt [B]
 - Spring Plate [C]
 - Springs [D]
 - Clutch Wheel [E]
- Replace the following steel plates [F].

Parts No.	Thickness
13089-1117	1.2 mm (0.05 in.)
13089-1094	1.6 mm (STD) (0.06 in.)
13089-1116	2.0 mm (0.08 in.)

NOTE

○ Do not use the steel plate of 1.2 mm (0.05 in.) and 2.0 mm (0.08 in.) thickness at the same time.

- Install the removed parts, and inspect the clutch plate assy thickness.
- Turn the friction plate [G] to shift its phase by 15°.
- Torque - Clutch Spring Bolt: 7.8 N·m (0.80 kgf·m, 69 in·lb)**

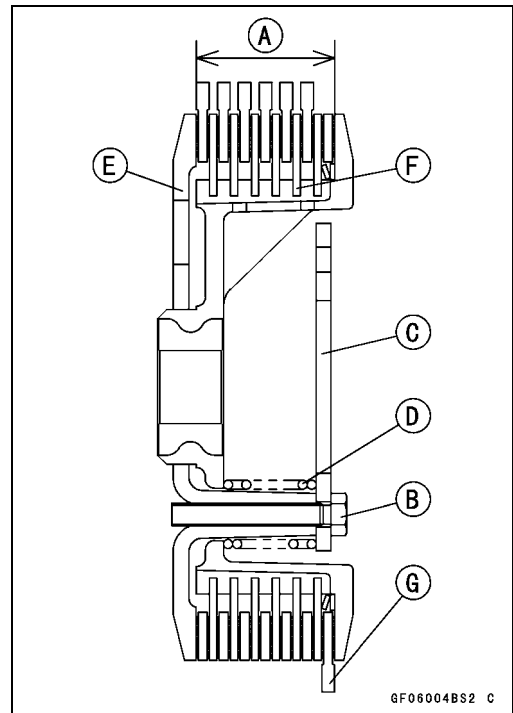

Clutch

Friction and Steel Plates Wear, Damage Inspection

NOTICE

If new friction plates are installed, apply engine oil to the surfaces of each plate to avoid seizure.

- Visually inspect the friction or steel plates for signs of seizure, overheating (discoloration) or uneven wear.
- ★ Replace any damaged plates.
- Measure the thickness of the friction plate [A] at several points.

Friction Plate Thickness

Standard: 2.92 ~ 3.08 mm (0.115 ~ 0.121 in.)

Service Limit: 2.7 mm (0.11 in.)

- ★ If the measurement is under the service limit, replace the friction plates.
- When you have changed friction plates or steel plates, measure the thickness of the clutch plate assy and make an adjustment, if necessary.

Friction and Steel Plates Warp

- Place each friction plate or steel plate on a surface plate [A], and measure the gap between the surface plate and each friction plate or steel plate [B] with a thickness gauge [C]. The gap is the amount of friction or steel plate warp.

Plate Warp

Friction Plate:

Standard: 0.15 mm (0.0060 in.) or less

Service Limit: 0.3 mm (0.01 in.)

Steel Plate:

Standard: 0.20 mm (0.0079 in.) or less

Service Limit: 0.3 mm (0.01 in.)

- ★ If the friction plate is warped more than the service limit, replace it with a new one.
- ★ If the steel plate is warped more than the service limit, replace it with a new one of the same thickness.

Clutch Spring Free Length Inspection

- Measure the free length [A] of the spring.

Clutch Spring Free Length

Standard: 35.4 mm (1.39 in.)

Service Limit: 33.9 mm (1.33 in.)

- ★ If the measurement is smaller than the service limit, replace the clutch spring.

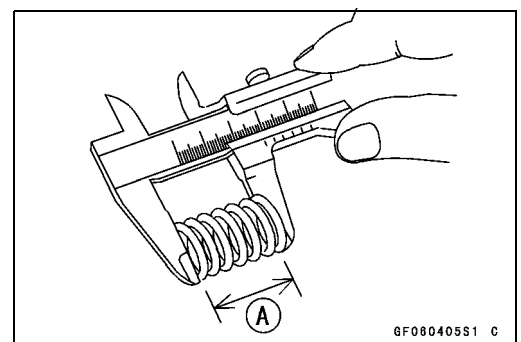
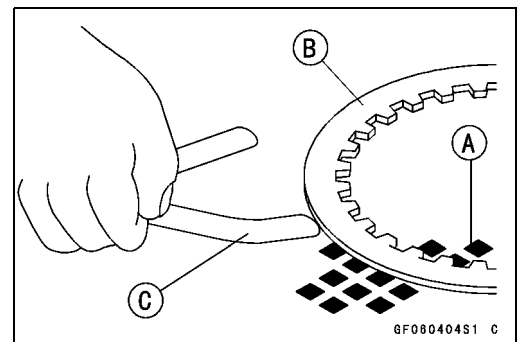
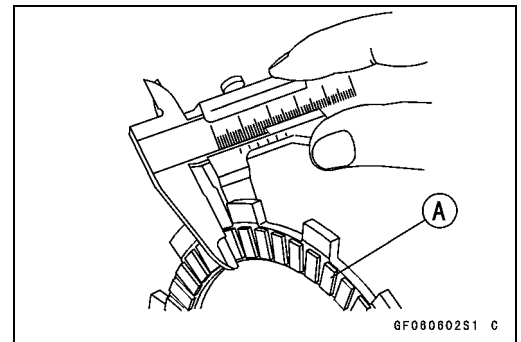

6-14 CLUTCH

Clutch

Clutch Housing Groove Inspection

- Visually inspect the grooves [A] of the clutch housing where the tangs [B] of the friction plates hit them.
- ★ If they are badly worn or if there are groove cuts where the tangs hit, replace the housing. Also, replace the friction plates if their tangs are damaged.

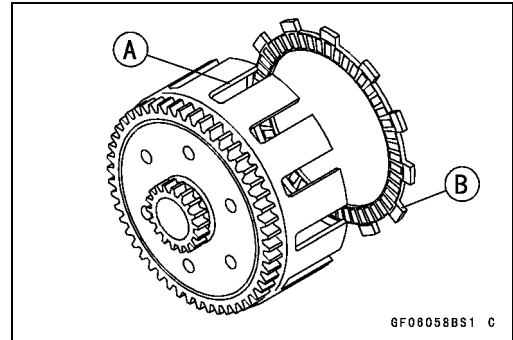

- Measure the clearance [C] between the tangs [A] on the friction plate and the fingers [B] of the clutch housing.

Friction Plate/Clutch Housing Clearance

Standard: 0.09 ~ 0.70 mm (0.0035 ~ 0.028 in.)

Service Limit: 0.95 mm (0.037 in.)

- ★ If this clearance is excessive, the clutch will be noisy.
- ★ If the clearance exceeds the service limit, replace the friction plates.

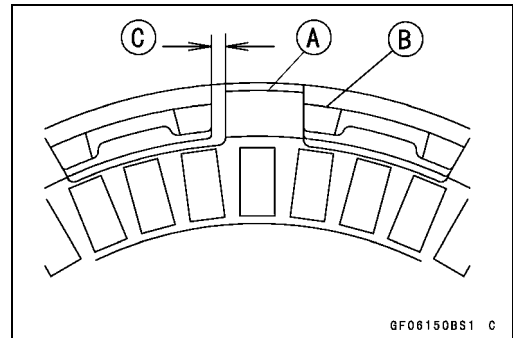

Clutch Hub Spline Inspection

- Visually inspect where the teeth [B] on the steel plates wear against the splines [A] of the clutch hub.
- ★ If there are notches worn into the splines, replace the steel plates.

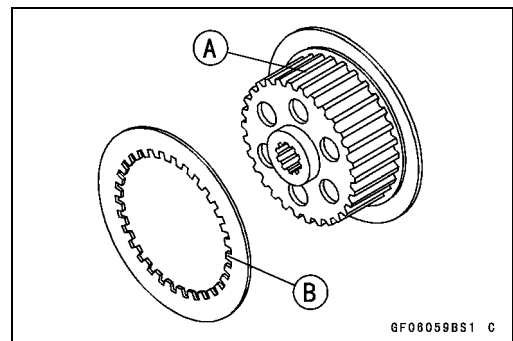

Engine Lubrication System

Table of Contents

Exploded View	7-2
Engine Oil Flow Chart.....	7-4
Specifications	7-6
Special Tools	7-7
Engine Oil and Oil Filter.....	7-8
Oil Level Inspection.....	7-8
Change Engine Oil.....	7-8
Oil Filter Replacement	7-8
Oil Screen Removal	7-9
Oil Screen Installation	7-9
Oil Pump.....	7-10
Oil Pump Removal	7-10
Oil Pump Installation	7-10
Oil Pump Disassembly.....	7-10
Oil Pump Assembly.....	7-11
Oil Pump Inspection.....	7-11
Oil Pipe	7-12
Oil Pipe Removal	7-12
Oil Pipe Installation	7-12
Oil Pressure.....	7-13
Oil Pressure Measurement	7-13
Relief Valve Inspection.....	7-13

7-2 ENGINE LUBRICATION SYSTEM

Exploded View

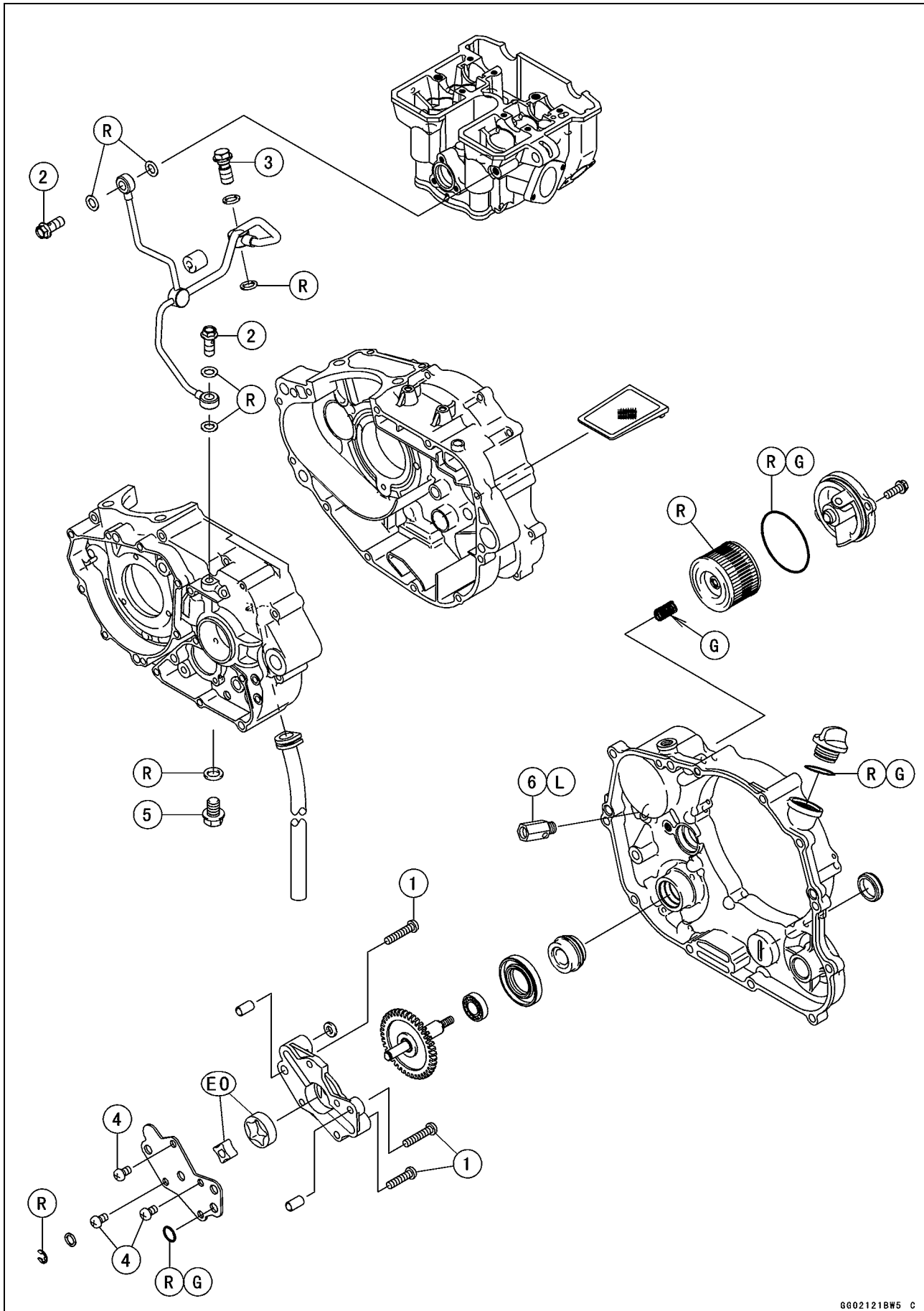

ENGINE LUBRICATION SYSTEM 7-3

Exploded View

No.	Fastener	Torque			Remarks
		N·m	kgf·m	ft·lb	
1	Oil Pump Mounting Screws	5.2	0.53	46 in·lb	
2	Oil Pipe Banjo Bolts (M8)	9.8	1.0	87 in·lb	
3	Oil Pipe Banjo Bolt (M10)	20	2.0	15	
4	Oil Pump Cover Screws	10	1.0	88 in·lb	
5	Engine Oil Drain Plug	15	1.5	11	
6	Oil Pressure Relief Valve	15	1.5	11	L

EO: Apply engine oil.

G: Apply grease.

L: Apply a non-permanent locking agent.

R: Replacement Parts

7-4 ENGINE LUBRICATION SYSTEM

Engine Oil Flow Chart

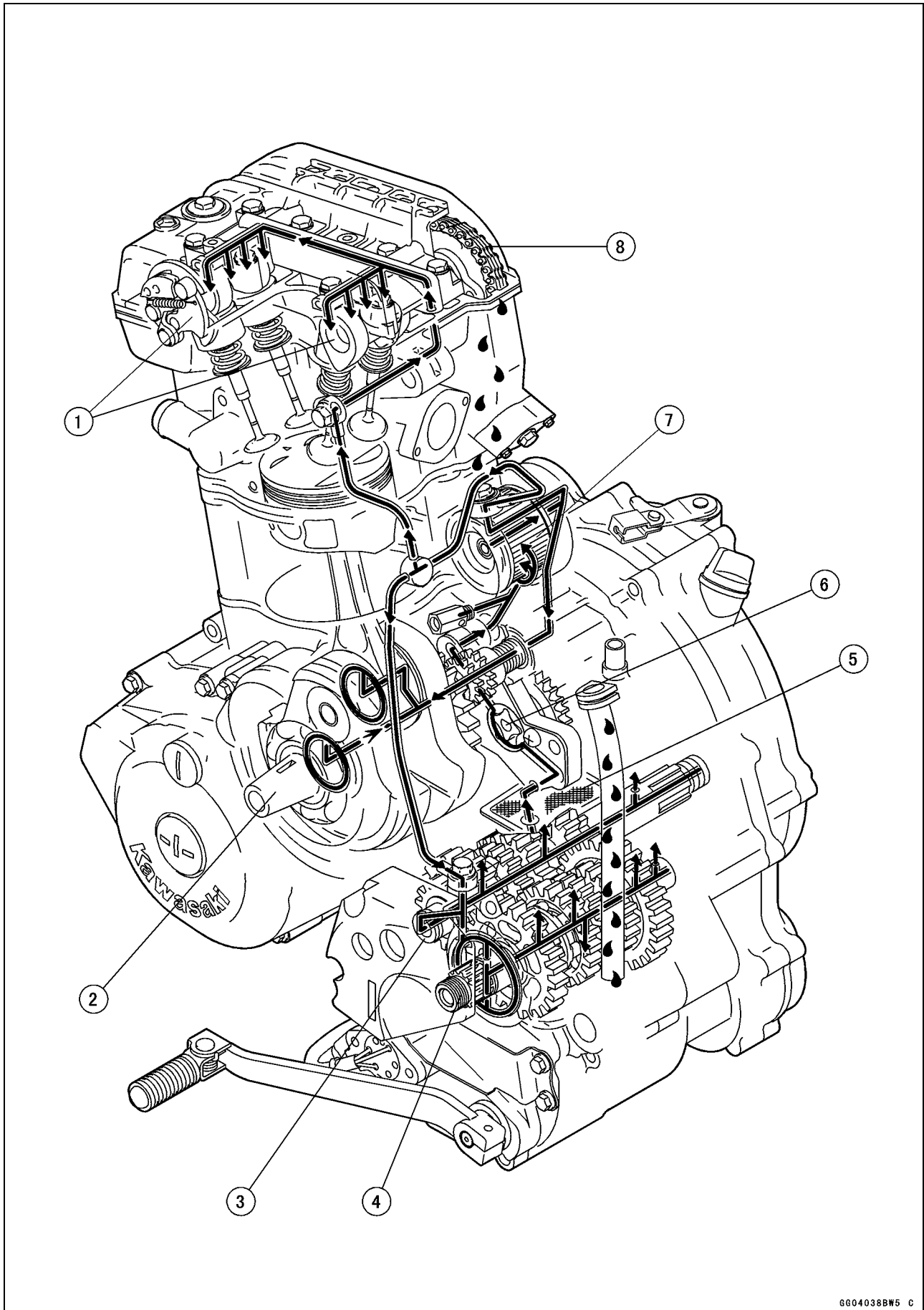

Engine Oil Flow Chart

→: Oil Flow

1. Camshaft
2. Crankshaft
3. Driveshaft
4. Output shaft
5. Oil Screens
6. Oil Pump
7. Oil filter
8. Camshaft Chain

7-6 ENGINE LUBRICATION SYSTEM

Specifications

Item	Standard
Engine Oil	
Grade	API SG, SH, SJ, SL or SM with JASO MA, MA1 or MA2
Viscosity	SAE 10W-40
Capacity:	
KLX250S9F ~ SAF/V9F ~ VAF	1.3 L (1.4 US qt) (when filter is not removed) 1.4 L (1.5 US qt) (when filter is removed) 1.5 L (1.6 US qt) (when engine is completely disassembled and dry)
KLX250SBF	1.0 L (1.1 US qt) (when filter is not removed) 1.1 L (1.2 US qt) (when filter is removed) 1.3 L (1.4 US qt) (when engine is completely disassembled and dry)
Level	Between upper and lower level lines (Wait several minutes after the idling or running.)
Oil Pressure (engine speed 4 000 rpm, oil temperature 90 °C (194 °F))	78 ~ 147 kPa (0.8 ~ 1.5 kgf/cm ² , 11 ~ 21 psi)

Special Tools

Oil Pressure Gauge, 5 kgf/cm²:
57001-125

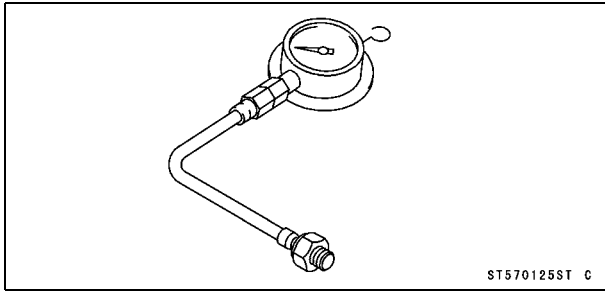

Oil Pressure Cap, M10 × 1.25:
57001-1361

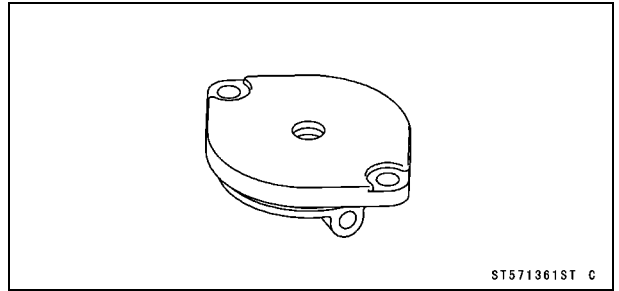

Oil Pressure Gauge Adapter, M10 × 1.25:
57001-1182

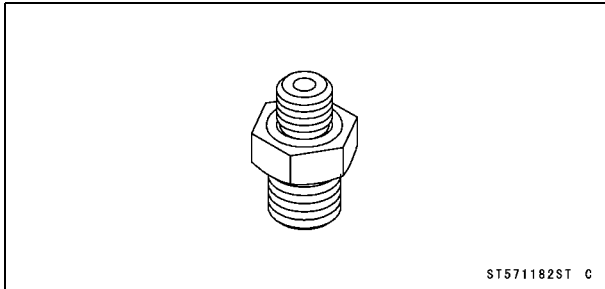

7-8 ENGINE LUBRICATION SYSTEM

Engine Oil and Oil Filter

⚠ WARNING

Vehicle operation with insufficient, deteriorated, or contaminated engine oil will cause accelerated wear and may result in engine seizure, accident, and injury. Check the oil level before each use and change the oil and filter according to the periodic maintenance chart.

Oil Level Inspection

- Check that the engine oil level is between the upper [A] and lower [B] levels in the gauge.

NOTE

- Situate the motorcycle so that it is perpendicular to the ground.
- If the motorcycle has just been used, wait several minutes for all the oil to drain down.
- If the oil has just been changed, start the engine and run it for several minutes at idle speed. This fills the oil filter with oil. Stop the engine, then wait several minutes until the oil settles.

NOTICE

Racing the engine before the oil reaches every part can cause engine seizure.

- ★ If the oil level is too high, remove the excess oil, using a syringe or some other suitable device.
- ★ If the oil level is too low, add the correct amount of oil through the oil filter opening. Use the same type and make of oil that is already in the engine.

NOTE

- If the engine oil type and make are unknown, use any brand of the specified oil to top off the level in preference to running the engine with the oil level low. Then at your earliest convenience, change the oil completely.

Change Engine Oil

- Refer to the Engine Oil Change in the Periodic Maintenance chapter.

Oil Filter Replacement

- Refer to the Oil Filter Replacement in the Periodic Maintenance chapter.

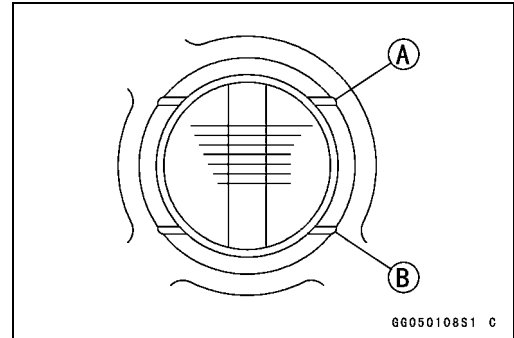

Engine Oil and Oil Filter

Oil Screen Removal

- Remove the right engine cover (see Right Engine Cover Removal in the Clutch chapter).
- Pull the oil screen [A] out of the crankcase.
- Wash the oil screen with a high-flash point solvent.

⚠ WARNING

Gasoline and low-flash point solvents can be flammable and/or explosive and cause severe burns. Clean the oil screen in a well-ventilated area, and take care that there is no spark or flame anywhere near the working areas. Do not use gasoline or low-flash point solvents to clean the oil screen.

NOTE

○ While cleaning the oil screens, check for any metal particles that might indicate internal engine damage.

- Inspect the oil screen for damage.
- ★ If it shows any signs of damage, replace it with a new one.

Oil Screen Installation

- The oil screen [A] should be installed in the crankcase in such a manner that its narrower side [B] shall be inserted into the crankcase first.
- Install the right engine cover (see Right Engine Cover Installation in the Clutch chapter).

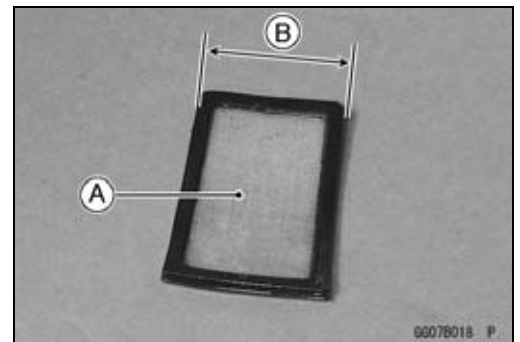
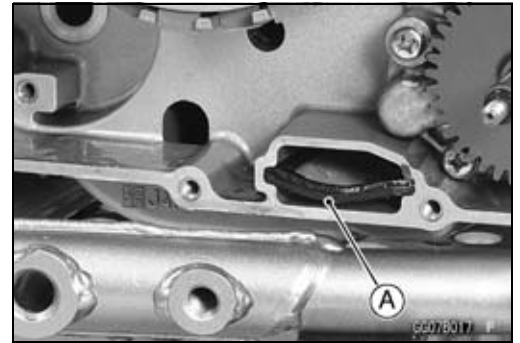

7-10 ENGINE LUBRICATION SYSTEM

Oil Pump

Oil Pump Removal

- Remove:
 - Right Engine Cover (see Right Engine Cover Removal in the Clutch chapter)
 - Screws [A]
 - Oil Pump [B]

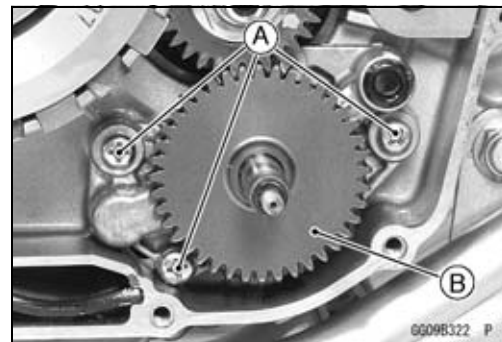

Oil Pump Installation

- Install the dowel pins [A] and O-ring [B] into the crankcase.
- Install the oil pump.

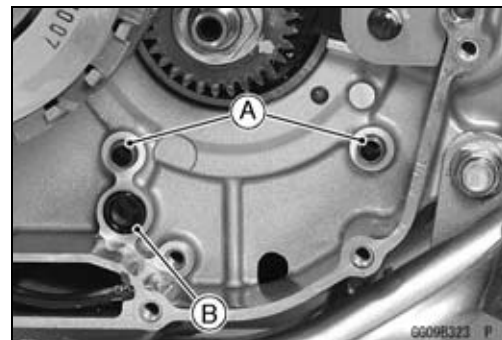

- Tighten:
 - Torque - Oil Pump Mounting Screws [A]: 5.2 N·m (0.53 kgf·m, 46 in·lb)**
- Install the O-ring [B] so that swelled side facing outward.
- Install the right engine cover (see Right Engine Cover Installation in the Clutch chapter).



Oil Pump Disassembly

- Remove:
 - Oil Pump (see Oil Pump Removal)
 - Circlip [A]
 - Washer [B]
 - Oil Pump Gear [C]
 - Screws [D]
 - Oil Pump Cover [E]

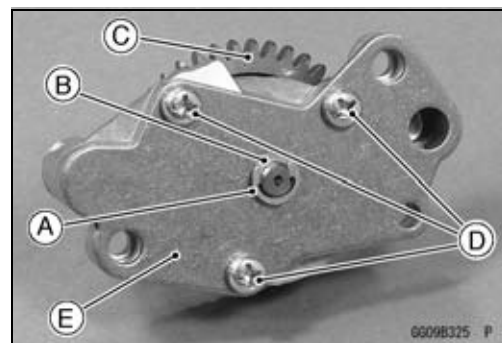

- Remove:
 - Inner Rotor [A]
 - Outer Rotor [B]

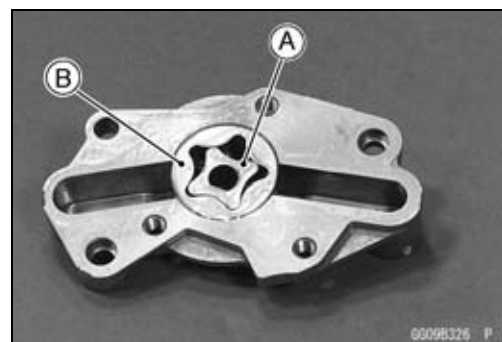

Oil Pump

Oil Pump Assembly

- Apply engine oil to the inner and outer rotors.
- Install the following parts to the oil pump body [A].
 - Outer Rotor [B]
 - Inner Rotor [C]

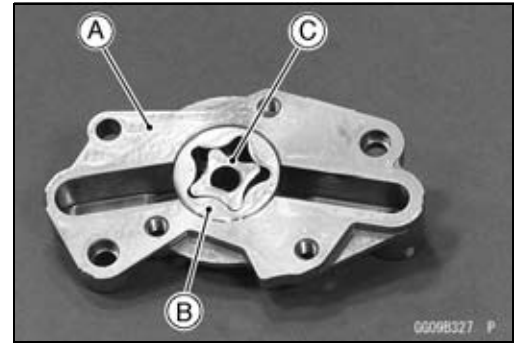

- Replace the circlip [A] with a new one.
- Install:
 - Oil Pump Gear [B]
 - Oil Pump Cover [C]
 - Washer [D]
 - Circlip
- Tighten:
 - Torque - Oil Pump Cover Screws [E] : 10 N·m (1.0 kgf·m, 88 in·lb)**

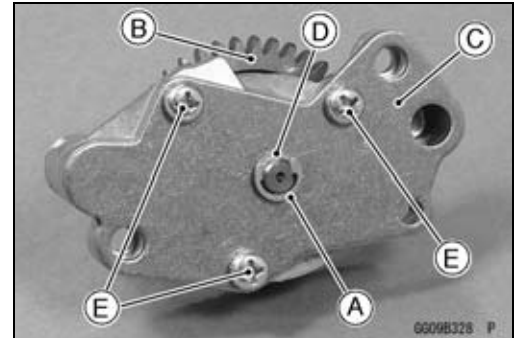

Oil Pump Inspection

- Disassemble the oil pump (see Oil Pump Disassembly).
- Visually inspect the oil pump body, outer rotors and the inner rotors.
- ★ If the oil pump is any damaged or unevenly worn, replace the rotors, cover, or oil pump body.

7-12 ENGINE LUBRICATION SYSTEM

Oil Pipe

Oil Pipe Removal

- Remove the starter motor (see Starter Motor Removal in the Electrical System chapter).
- Remove the oil pipe banjo bolt [A] provided on the right engine cover side.

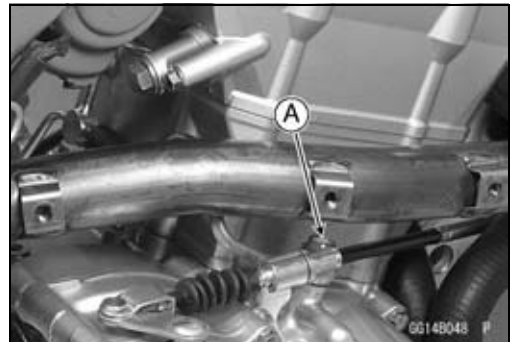

- Remove the banjo bolts [A] on the cylinder head and crankcase sides and take out the oil pipe.

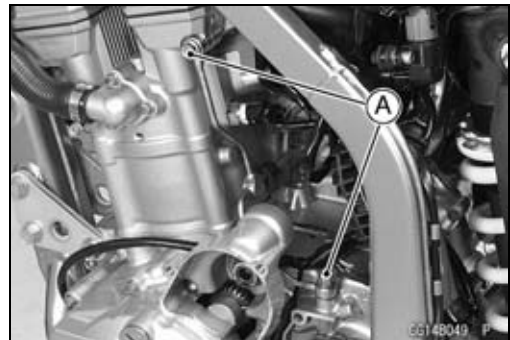

- Remove the oil pipe [A] while turning it as shown.

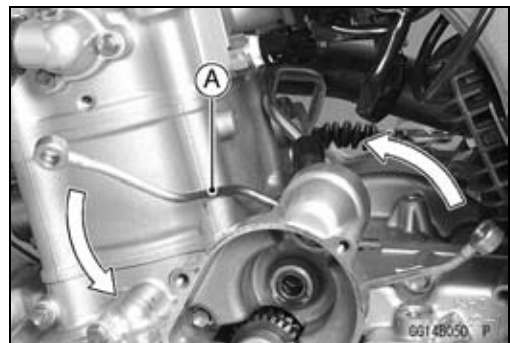

Oil Pipe Installation

- Replace the washers on both sides of the oil pipe with new ones.
- Tighten:

Torque - Oil Pipe Banjo Bolts:

(M8) 9.8 N·m (1.0 kgf·m, 87 in·lb)

(M10) 20 N·m (2.0 kgf·m, 15 ft·lb)

Oil Pressure

Oil Pressure Measurement

- Remove the oil filter cover.
- Install the O-ring to the oil pressure cap.
- Install the oil pressure cap [A].
- Align the oil passage holes of the oil pressure cap and right engine cover.
- Install the oil pressure gauge adapter [B] and oil pressure gauge [C].

Special Tools - Oil Pressure Gauge, 5 kgf/cm²: 57001-125
Oil Pressure Gauge Adapter, M10 × 1.25: 57001-1182
57001-1182
Oil Pressure Cap, M10 × 1.25: 57001-1361

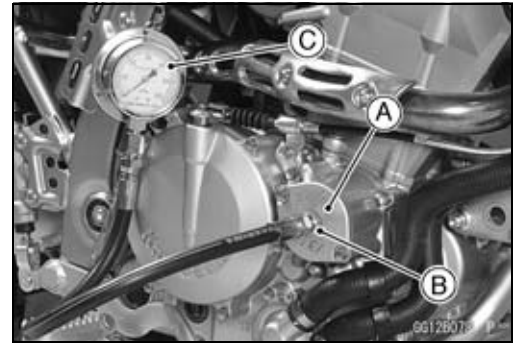

⚠ WARNING

Hot oil can cause severe burns. Beware of hot engine oil that will drain through the oil filter when the plug is removed.

NOTE

○ Measure the oil pressure after the engine is thoroughly warmed up.

- Start up the engine and measure an oil pressure value at 4 000 rpm.

Oil Pressure (engine speed 4 000 rpm, oil temperature 90 °C (194°F))

Standard: 78 ~ 147 kPa (0.8 ~ 1.5 kgf/cm², 11 ~ 21 psi)

- ★ If the reading is less than the specified value, inspect the oil pump and relief valve.
- ★ If the oil pump and relief valve are not at fault, inspect the rest of the lubrication system.
- Stop the engine, remove the gauge.
- Install the oil filter cover (see Oil Filter Replacement in the Periodic Maintenance chapter).

Relief Valve Inspection

- Remove the right engine cover (see Right Engine Cover Removal in the Clutch chapter).
- Remove the oil pressure relief valve [A].



7-14 ENGINE LUBRICATION SYSTEM

Oil Pressure

- Check to see if the steel ball [A] inside the valve slides smoothly when pushing it in with a wooden or other soft rod, and see if it comes back to original position by valve spring pressure [B].

NOTE

○ Since the relief valve cannot be disassembled, inspect it as an assy.

- ★ If the steel ball does not move smoothly, wash the relief valve with a high-flash point solvent and blow dirt out with compressed air.
- ★ If the steel ball does not move smoothly even after the valve is cleaned, replace the relief valve assy with a new one.

⚠ WARNING

Gasoline and low-flash point solvents can be flammable and/or explosive and cause severe burns. Clean the relief valve in a well-ventilated area, and take care that there is no spark or flame anywhere near the working areas. Do not use gasoline or low-flash point solvents to clean the relief valve.

- Apply a non-permanent locking agent to the threads of relief valve and install it.

Torque - Oil Pressure Relief Valve: 15 N·m (1.5 kgf·m, 11 ft·lb)

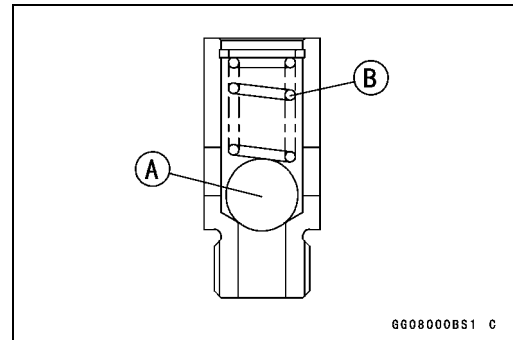

Engine Removal/Installation

Table of Contents

Exploded View	8-2
Special Tool	8-4
Engine Removal/Installation	8-5
Engine Removal	8-5
Engine Installation	8-7

8-2 ENGINE REMOVAL/INSTALLATION

Exploded View

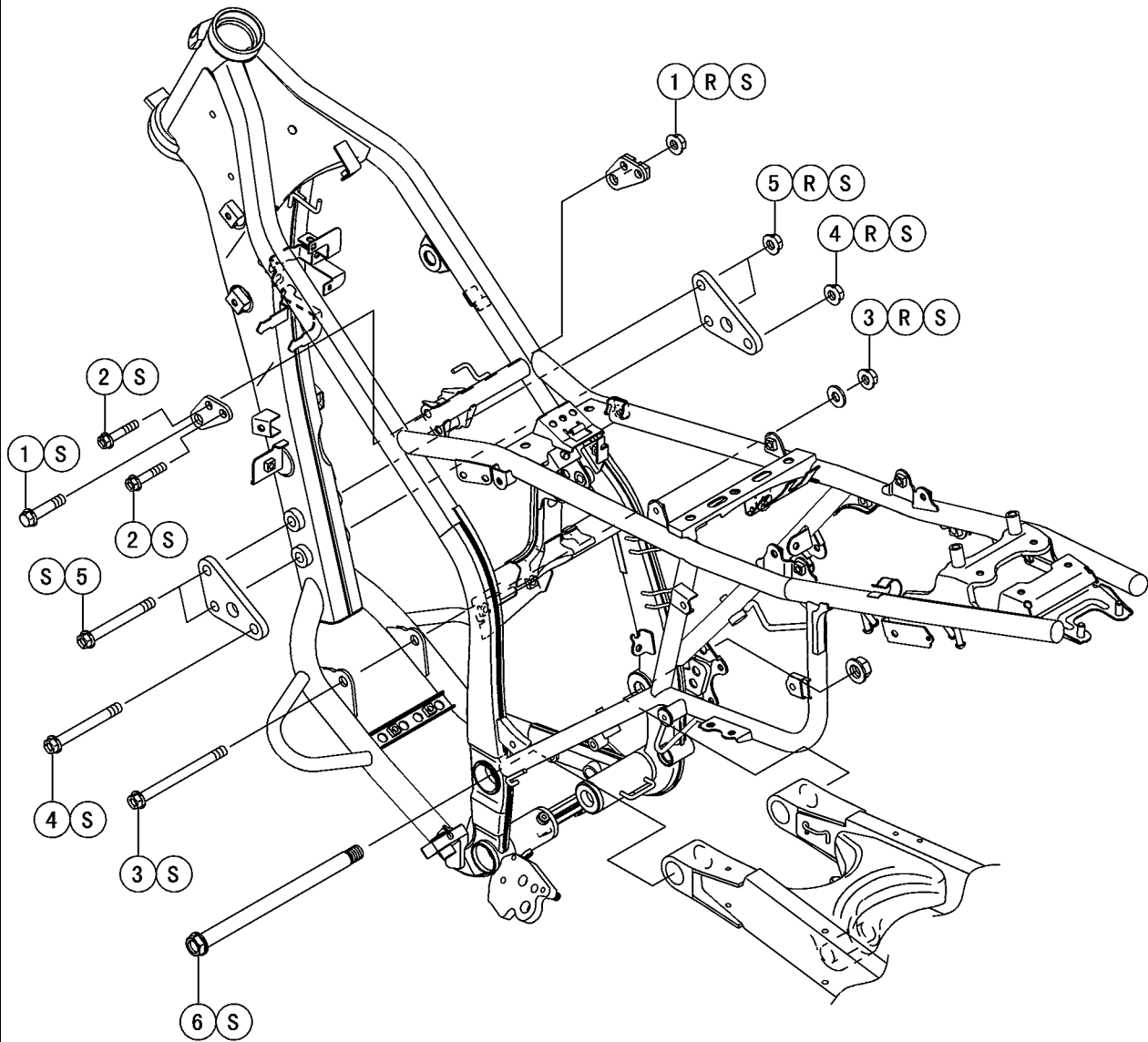

ENGINE REMOVAL/INSTALLATION 8-3

Exploded View

No.	Fastener	Torque			Remarks
		N·m	kgf·m	ft·lb	
1	Upper Engine Mounting Bolt and Nut	50	5.1	37	R, S
2	Upper Engine Bracket Bolts	23	2.3	17	S
3	Lower Engine Mounting Bolt and Nut	50	5.1	37	R, S
4	Front Engine Mounting Bolt and Nut	50	5.1	37	R, S
5	Front Engine Bracket Bolts and Nuts	50	5.1	37	R, S
6	Swingarm Pivot Shaft Nut	88	9.0	65	S

S: Follow the specified tightening sequence.

8-4 ENGINE REMOVAL/INSTALLATION

Special Tool

Jack:
57001-1238

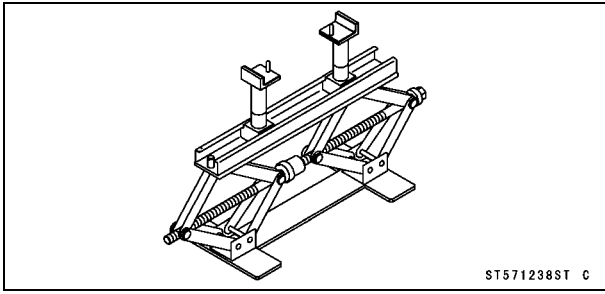

Engine Removal/Installation

Engine Removal

- Place a jack [A] under the frame to raise the rear wheel off the ground.

Special Tool - Jack: 57001-1238

⚠ WARNING

Since the swingarm pivot shaft also serves as the engine mounting bolt, removing it may cause the motorcycle to fall over and cause injury. When removing the swingarm pivot shaft, be sure the frame is well supported so the motorcycle will not fall when the pivot is removed.

- Squeeze the front brake lever, and hold it with a band [A] to prevent the motorcycle from running forward.

⚠ WARNING

Motorcycle may fall over unexpectedly resulting in an accident or injury. Be sure to hold the front brake when removing the engine.

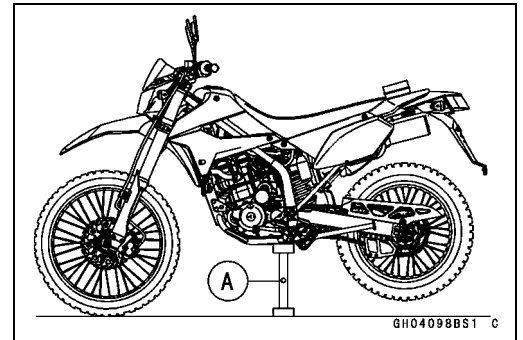

- Drain:
 - Coolant (see Coolant Change in the Periodic Maintenance chapter)
 - Engine Oil (see Engine Oil Change in the Periodic Maintenance chapter)
- Remove:
 - Fuel Tank (see Fuel Tank Removal in the Fuel System (DFI) chapter)
 - Throttle Body Assy (see Throttle Body Assy Removal in the Fuel System (DFI) chapter)
 - Radiator (see Radiator Removal in the Cooling System chapter)
 - Alternator and Crankshaft Sensor Lead Connectors (Alternator Cover Removal in the Electrical System chapter)
 - Neutral Switch Connector (see External Shift Mechanism Removal in the Crankshaft/Transmission chapter)
 - Exhaust Pipe (see Exhaust Pipe Removal in the Engine Top End chapter)
 - Clutch Cable Lower End (see Clutch Cable Removal in the Clutch chapter)
 - Brake Pedal (see Brake Pedal Removal in the Brakes chapter)
 - Engine Sprocket (see Engine Sprocket Removal in the Final Drive chapter)

8-6 ENGINE REMOVAL/INSTALLATION

Engine Removal/Installation

- Remove:
 - Right Front Footpeg Bracket Nut [A]
 - Right Front Footpeg Bracket Bolt [B]
 - Right Front Footpeg [C]
 - Brake Light Switch Spring [D]
 - Brake Pedal Return Spring [E]
 - Rear Master Cylinder Mounting Screws [F]

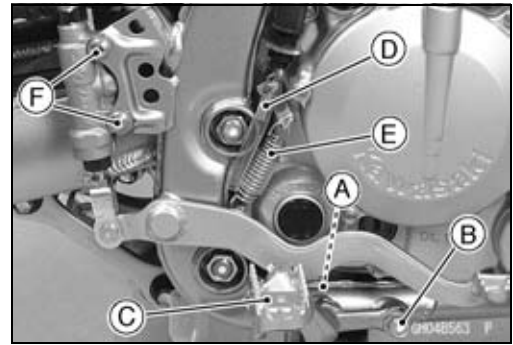

- Remove:
 - Bolt [A]
- Take out the rear brake light switch from the frame.

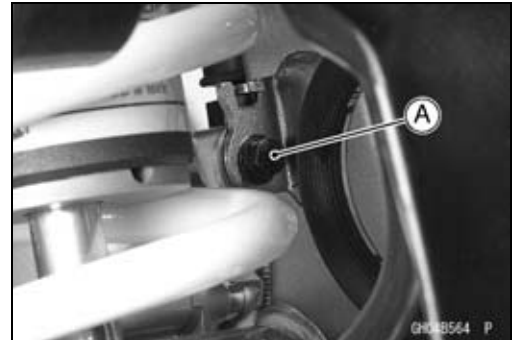

- Remove:
 - Regulator/Rectifier Connector [A]
 - Bolt [B]
 - Engine Ground Lead [C]
 - Bolt [D]
 - Bracket [E]

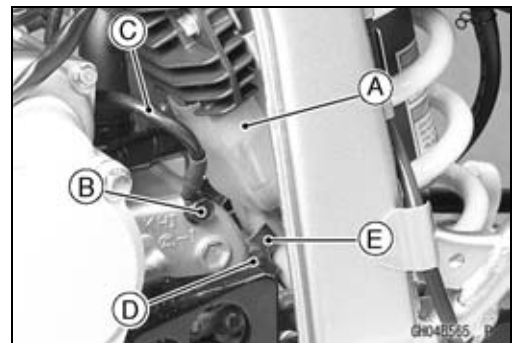

- Remove:
 - Water Temperature Sensor Connector [A]



- Slide back the rubber boots [A].
- Remove the terminal nut [B] to free the starter motor cable [C].
- Disconnect the breather hose [D] from the right crankcase.

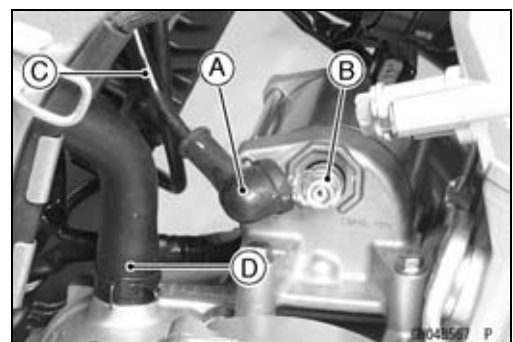

Engine Removal/Installation

- Remove:
 - Upper Engine Mounting Bolt [A] and Nut
 - Upper Engine Bracket Bolts [B]
 - Upper Engine Bracket [C]

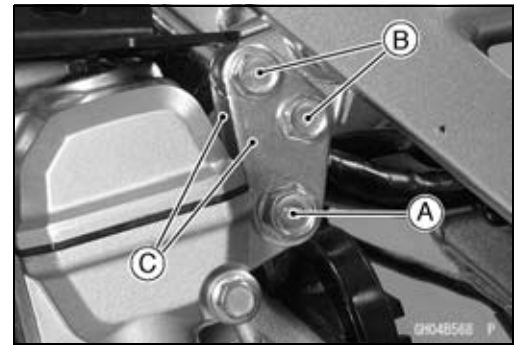

- Remove:
 - Front Engine Mounting Bolt and Nut [A]
 - Front Engine Bracket Bolts and Nuts [B]
 - Front Engine Brackets [C]
 - Lower Engine Mounting Bolt and Nut [D]
- Remove the swingarm pivot shaft nut [E], and pull out the swingarm pivot shaft.
- Loosen the rocker arm pivot shaft nut [F], if the swingarm pivot shaft does not pull out.
- Drop the brake pedal [G].
- Lift the engine a little and lean it to the right.
- Take out the engine to the right.

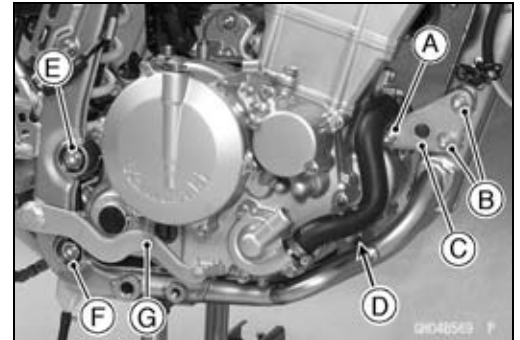

Engine Installation

- Support the engine with a commercially available stand and place it into the frame in reverse order of dismantling.
- Insert the swingarm pivot shaft from the left side, and put the engine in its original position.
- Replace:
 - Lower Engine Mounting Nut
 - Front Engine Bracket Nuts
 - Front Engine Mounting Nut
 - Upper Engine Mounting Nut
- Tighten the mounting bolts and nuts following the specified tightening sequence [1 to 8] as shown.

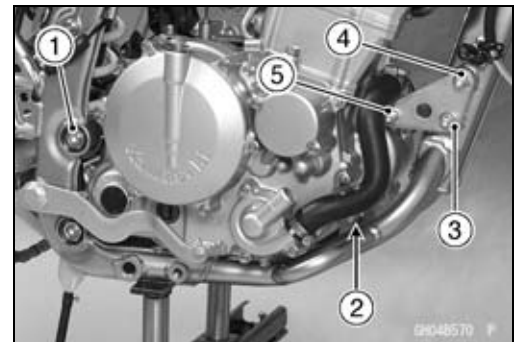

Torque - Swingarm Pivot Shaft Nut: 88 N·m (9.0 kgf·m, 65 ft·lb)

Lower Engine Mounting Bolt and Nut: 50 N·m (5.1 kgf·m, 37 ft·lb)

Front Engine Bracket Bolts and Nuts: 50 N·m (5.1 kgf·m, 37 ft·lb)

Front Engine Mounting Bolt and Nut: 50 N·m (5.1 kgf·m, 37 ft·lb)

Upper Engine Bracket Bolts: 23 N·m (2.3 kgf·m, 17 ft·lb)

Upper Engine Mounting Bolt and Nut: 50 N·m (5.1 kgf·m, 37 ft·lb)

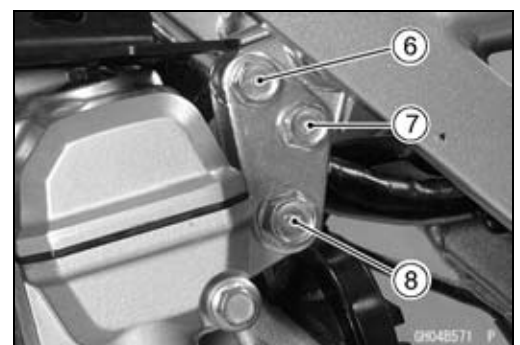

- Tighten the rocker arm pivot shaft nut, if loosen it.

Torque - Rocker Arm Pivot Shaft Nut: 98 N·m (10 kgf·m, 72 ft·lb)

- Instal the removed parts (see appropriate chapters).
- Run the leads, cables and hoses correctly (see Cable, Wire, and Hose Routing section in the Appendix chapter).

8-8 ENGINE REMOVAL/INSTALLATION

Engine Removal/Installation

- Adjust:
 - Throttle Cables (see Throttle Control System Inspection in the Periodic Maintenance chapter)
 - Drive Chain (see Drive Chain Slack Adjustment in the Periodic Maintenance chapter)
- Fill the engine with engine oil (see Engine Oil Change in the Periodic Maintenance chapter).
- Fill the engine with coolant and bleed the air from the cooling system (see Coolant Change in the Periodic Maintenance chapter).

Crankshaft/Transmission

Table of Contents

Exploded View	9-2	Starter Motor Clutch/Torque Limiter...	9-21
Specifications	9-6	Starter Motor Clutch	
Special Tools and Sealant	9-7	Removal/Installation	9-21
Crankcase	9-8	Starter Motor Clutch Disassembly	9-21
Crankcase Disassembly	9-8	Starter Motor Clutch Assembly	9-21
Crankcase Assembly	9-10	Starter Motor Clutch Inspection ...	9-21
Crankshaft/Connecting Rods.....	9-14	Torque Limiter Removal	9-21
Crankshaft Removal	9-14	Torque Limiter Inspection.....	9-22
Crankshaft Installation	9-14	Torque Limiter Installation	9-22
Crankshaft/Connecting Rod		Primary Gear	9-23
Cleaning	9-14	Primary Gear Removal	9-23
Connecting Rod Bend Inspection	9-15	Primary Gear Installation	9-23
Connecting Rod Twist Inspection.	9-15	Balancer	9-24
Connecting Rod Big End Radial		Balancer Removal.....	9-24
Clearance Inspection	9-15	Balancer Disassembly	9-24
Connecting Rod Big End Side		Balancer Assembly	9-24
Clearance Inspection	9-15	Balancer Installation.....	9-24
Crankshaft Runout Inspection.....	9-16	External Shift Mechanism.....	9-25
Transmission	9-17	Shift Pedal Removal	9-25
Transmission Removal	9-17	Shift Pedal Installation	9-25
Transmission Installation	9-17	External Shift Mechanism	
Transmission Disassembly	9-18	Removal	9-25
Transmission Assembly	9-18	External Shift Mechanism	
Shift Fork Bending Inspection	9-20	Installation	9-26
Shift Fork/Gear Groove Wear		External Shift Mechanism	
Inspection.....	9-20	Inspection.....	9-28
Shift Fork Guide Pin/Drum		Bearing, Oil seal	9-29
Groove Wear Inspection	9-20	Bearing Replacement	9-29
Gear Dog and Gear Dog Hole		Bearings Inspection	9-29
Damage Inspection	9-20	Oil Seal Inspection	9-29

9-2 CRANKSHAFT/TRANSMISSION

Exploded View

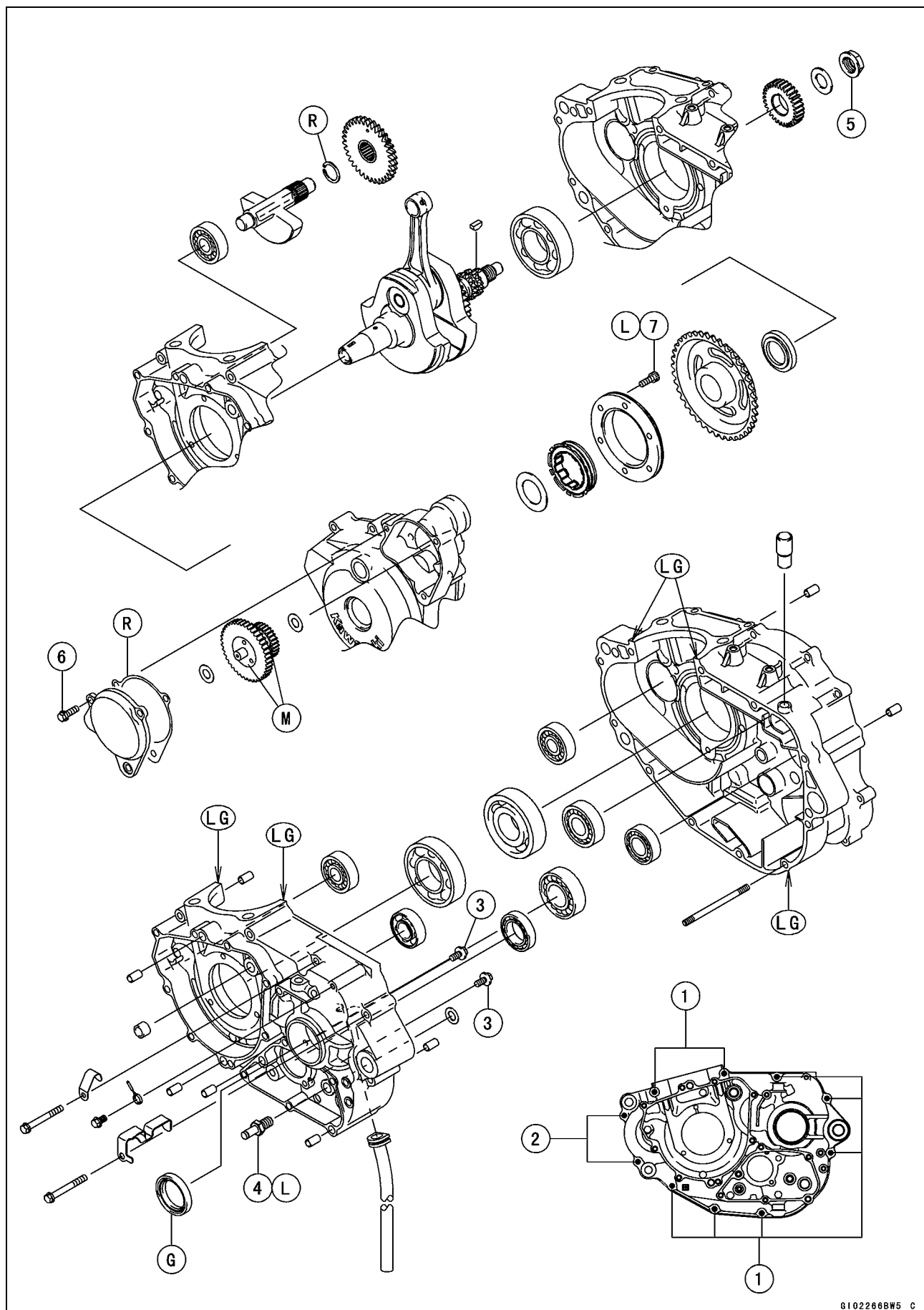

CRANKSHAFT/TRANSMISSION 9-3

Exploded View

No.	Fastener	Torque			Remarks
		N·m	kgf·m	ft·lb	
1	Crankcase Bolts	9.8	1.0	87 in·lb	
2	Crankcase Allen Bolts	12	1.2	106 in·lb	
3	Shift Drum Bearing Retaining Bolts	9.8	1.0	87 in·lb	
4	Shift Shaft Return Spring Pin	37	3.8	27	L
5	Primary Gear Nut	98	10	72	
6	Torque Limiter Cover Bolts	9.8	1.0	87 in·lb	
7	Starter Motor Clutch Bolts	12	1.2	106 in·lb	L

G: Apply grease.

L: Apply a non-permanent locking agent.

LG: Apply liquid gasket (Liquid Gasket, TB1216B: 92104-1064).

M: Apply molybdenum disulfide grease.

R: Replacement Parts

9-4 CRANKSHAFT/TRANSMISSION

Exploded View

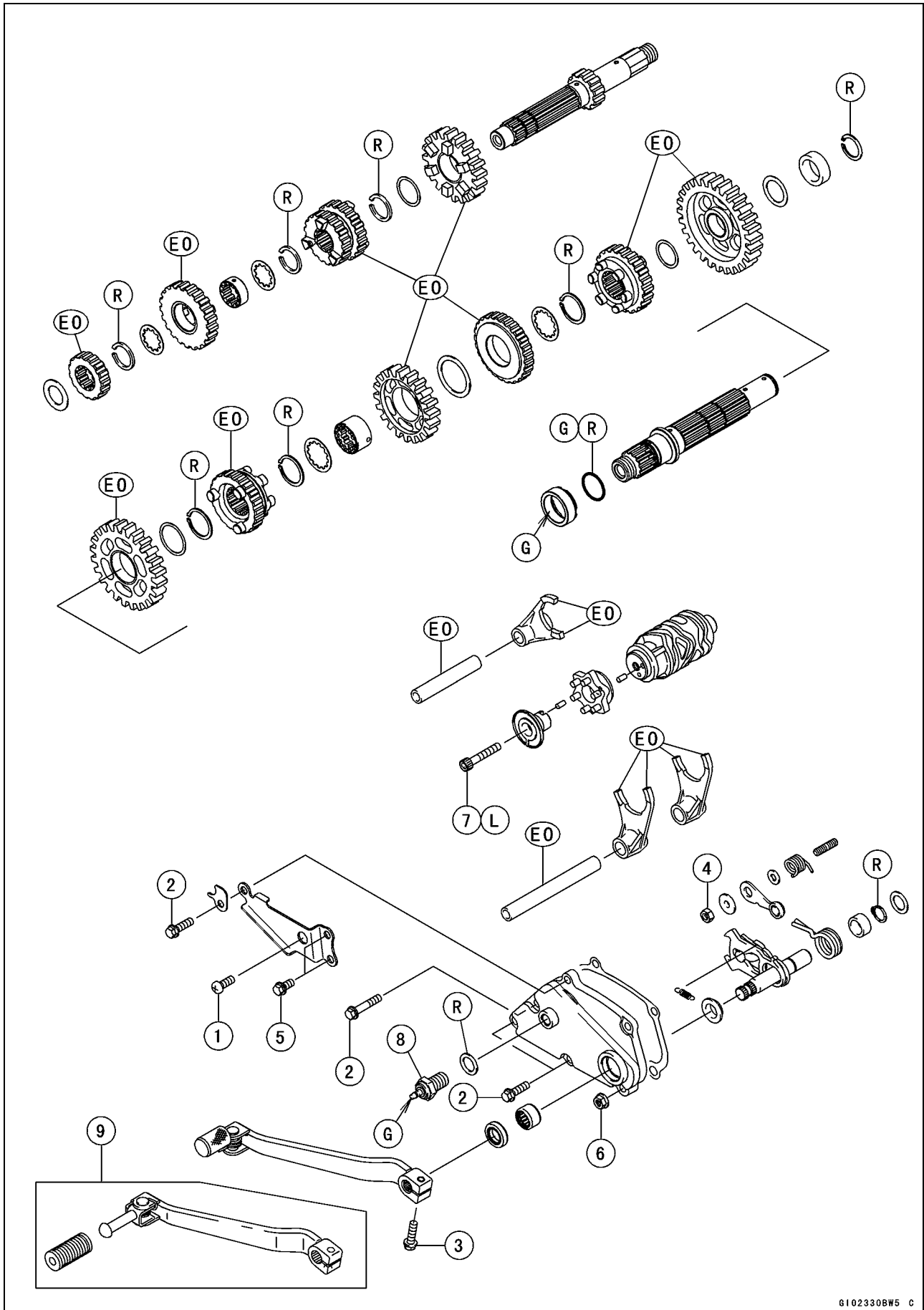

CRANKSHAFT/TRANSMISSION 9-5

Exploded View

No.	Fastener	Torque			Remarks
		N·m	kgf·m	ft·lb	
1	External Shift Mechanism Cover Screw	5.2	0.53	46 in·lb	
2	External Shift Mechanism Cover Bolts	9.8	1.0	87 in·lb	
3	Shift Pedal Bolt	9.8	1.0	87 in·lb	
4	Gear Positioning Lever Nut	9.8	1.0	87 in·lb	
5	Drive Chain Guard Plate Bolts	9.8	1.0	87 in·lb	
6	External Shift Mechanism Cover Nut	9.8	1.0	87 in·lb	
7	Shift Drum Cam Holder Bolt	12	1.2	106 in·lb	L
8	Neutral Switch	14.7	1.5	130 in·lb	G

9. KLX250V Model

EO: Apply engine oil.

G: Apply grease.

L: Apply a non-permanent locking agent.

R: Replacement Parts

9-6 CRANKSHAFT/TRANSMISSION

Specifications

Item	Standard	Service Limit
Crankshaft, Connecting Rod		
Connecting Rod Bend	— — —	0.2 mm (0.008 in.)
Connecting Rod Twist	— — —	0.2 mm (0.008 in.)
Connecting Rod Big End Radial Clearance	0.008 ~ 0.02 mm (0.0003 ~ 0.0008 in.)	0.07 mm (0.003 in.)
Connecting Rod Big End Side Clearance	0.25 ~ 0.35 mm (0.0098 ~ 0.014 in.)	0.55 mm (0.022 in.)
Crankshaft Runout	TIR 0.03 mm (0.001 in.) or less	TIR 0.08 mm (0.003 in.)
Transmission		
Shift Fork Ear Thickness	4.9 ~ 5.0 mm (0.19 ~ 0.20 in.)	4.8 mm (0.19 in.)
Gear Shift Fork Groove Width	5.05 ~ 5.15 mm (0.199 ~ 0.203 in.)	5.2 mm (0.20 in.)
Shift Fork Guide Pin Diameter	5.9 ~ 6.0 mm (0.23 ~ 0.24 in.)	5.8 mm (0.23 in.)
Shift Drum Groove Width	6.05 ~ 6.20 mm (0.238 ~ 0.244 in.)	6.3 mm (0.25 in.)

Special Tools and Sealant

**Bearing Puller:
57001-135**

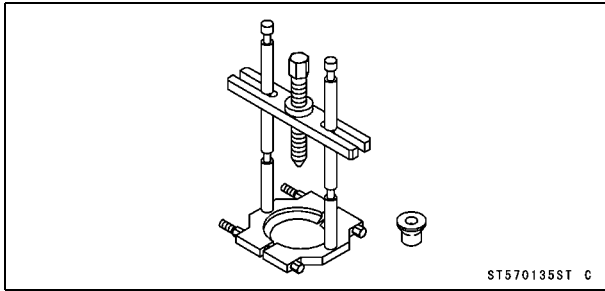

**Grip:
57001-1591**

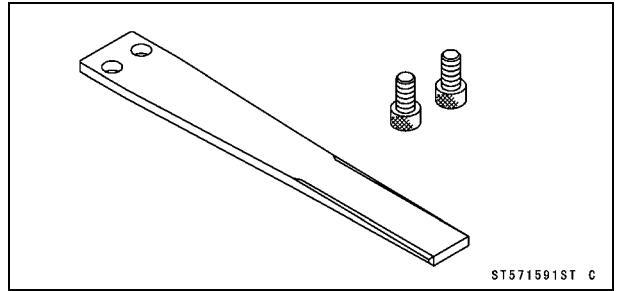

**Outside Circlip Pliers:
57001-144**

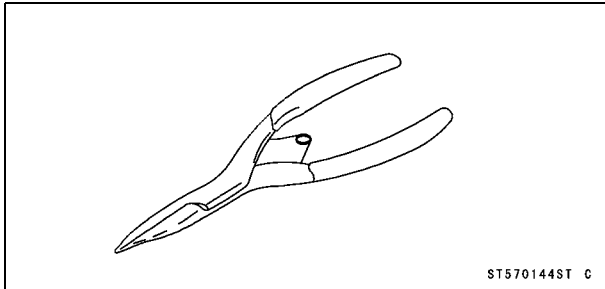

**Gear Holder:
57001-1602**

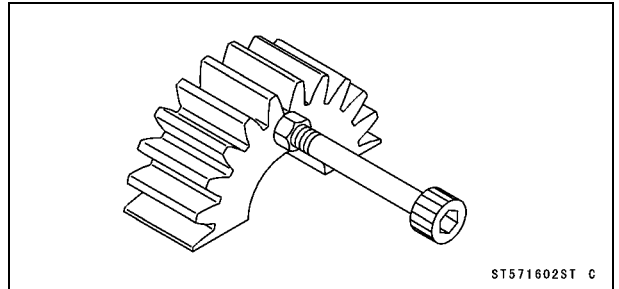

**Bearing Driver Set:
57001-1129**

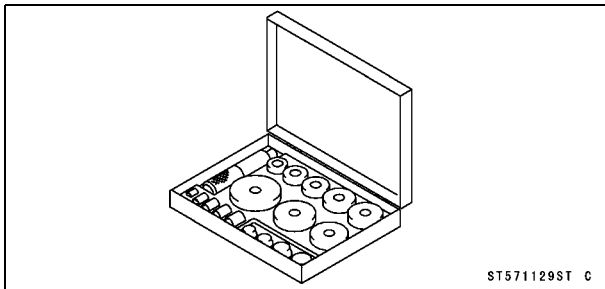

**Rotor Holder:
57001-1723**

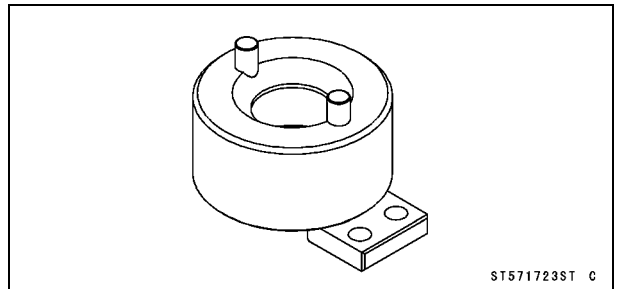

**Crankshaft Jig:
57001-1174**

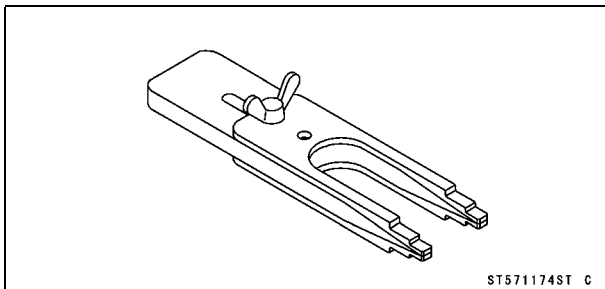

**Liquid Gasket, TB1216B:
92104-1064**

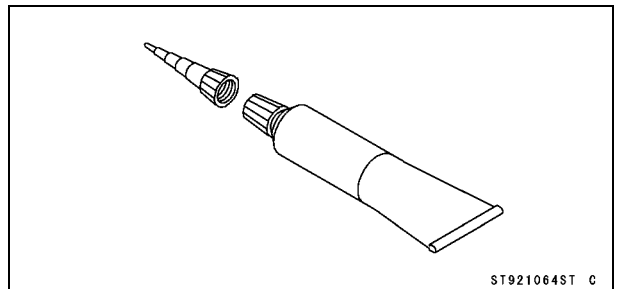

9-8 CRANKSHAFT/TRANSMISSION

Crankcase

Crankcase Disassembly

- Remove the engine from the frame (see Engine Removal in the Engine Removal/Installation chapter).
- Remove:
 - Torque Limiter (see Torque Limiter Removal)
 - Starter Motor (see Starter Motor Removal in the Electrical System chapter)
 - Oil Pipe (see Oil Pipe Removal in the Engine Lubrication System chapter)
 - Cylinder and Piston (see Cylinder Removal, Piston Removal in the Engine Top End chapter)
 - Water Pump Cover and Impeller (see Water Pump Removal in the Cooling System chapter)
 - Right Engine Cover (see Right Engine Cover Removal in the Clutch chapter)
 - Clutch (see Clutch Removal in the Clutch chapter)
 - Oil Pump (see Oil Pump Removal in the Engine Lubrication System chapter)
 - Primary Gear (see Primary Gear Removal)
 - Camshaft Chain (see Camshaft Chain Removal in the Engine Top End chapter)
 - Alternator Rotor and Starter Motor Idle Gear (see Alternator Rotor Removal in the Electrical System chapter)
 - Shift Shaft Assembly (see External Shift Mechanism Removal)
- Remove the output shaft sleeve [A] and O-ring [B].

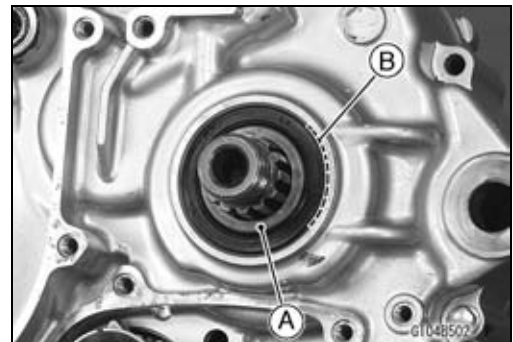

- Remove the circlip [A], and remove the collar [B] from the output shaft.

Special Tool - Outside Circlip Pliers: 57001-144

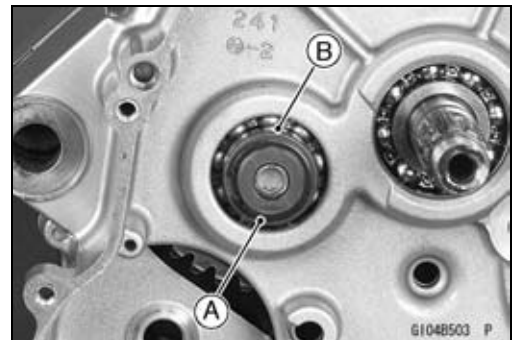

Crankcase

- Remove:
 - Crankcase Bolts [A]
 - Allen Bolts [B]

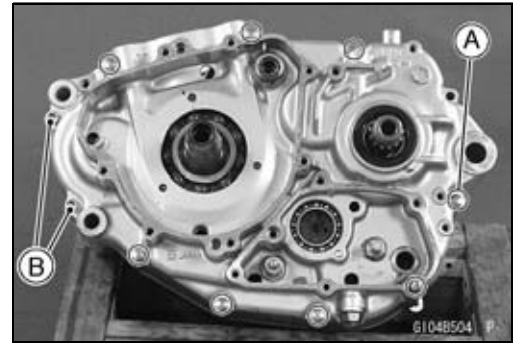

- Place it with the left crankcase facing downward.
- Pry the points [A] to split the crankcase halves apart, and remove the right crankcase half.



- Remove:
 - Balancer [A]
 - Shift Rods [B]
 - Shift Forks [C]
 - Shift Drum [D]
 - Transmission [E]

NOTE

○ Turn the crankshaft [F] to the position where the crank web [G] does not get in the way in removing the transmission.

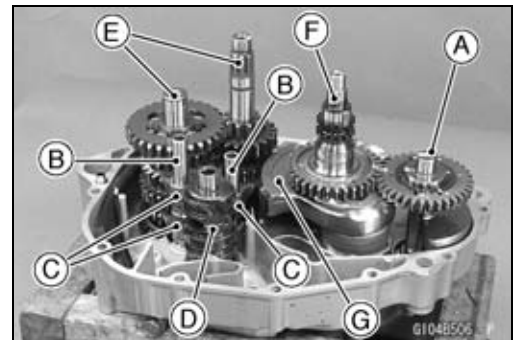

- Pull the crankshaft out of the left crankcase (see Crankshaft Removal).

NOTICE

Do not remove the bearing and oil seal in the crankcase unless it is absolutely necessary. Any removed parts should be replaced with new ones.

9-10 CRANKSHAFT/TRANSMISSION

Crankcase

Crankcase Assembly

NOTICE

The right and left crankcase halves are machined at the factory in the assembled state, so they must be replaced as a set.

- Remove the old gasket from the mating surfaces of the crankcase halves, and clean off the crankcase with a high flash-point solvent.
- Using compressed air, blow out the oil passage.

⚠ WARNING

Gasoline and low-flash point solvents can be flammable and/or explosive and cause severe burns. Clean the the crankcase in a well-ventilated area, and take care that there is no spark or flame anywhere near the working areas. Do not use gasoline or low-flash point solvents to clean the crankcase.

- If removed, the oil seal replacement may be required. Press in the new oil seal using a press and suitable tools so that the seal surface [B] is flush with the surface of the crankcase [A].
- Apply grease to the oil seal lips [C].

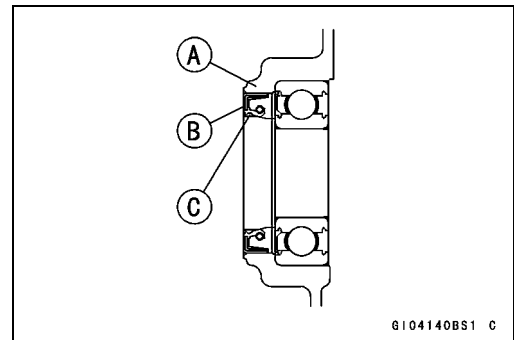

- Using a suitable jig [A], support the crankcase bearing boss.
- Using a press or the bearing driver set [C], install the ball bearing [B] until it bottoms out.

NOTICE

Support the crankcase bearing boss when pushing the bearing, otherwise the crankcase could be damaged.

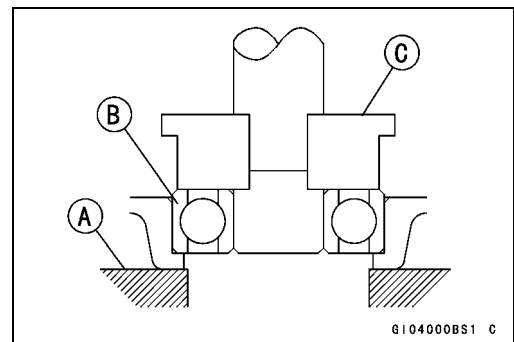

Special Tool - Bearing Driver Set: 57001-1129

- A bearing sealed on one end should be installed with the sealed end facing the outside of the engine.

Crankcase

- Tighten the retaining bolts [A].
Torque - Shift Drum Bearing Retaining Bolts: 9.8 N·m (1.0 kgf·m, 87 in·lb)
- Install the oil return pipe [B].
- Install the crankshaft (see Crankshaft Installation).



- Apply engine oil to the crankcase bearing, transmission gears and bearings, shift drum, shift forks and shift shaft.
- Turn the crankshaft [A] to the position where the crankshaft web does not get in the way of the drive shaft [B], and insert the drive shaft and the output shaft [C] together as a set into the crankcase.

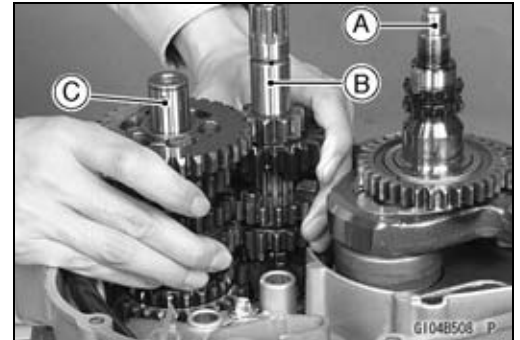

- Install:
 Shift Forks [A] (see Transmission Installation)
 Shift Drum [B] (see Transmission Installation)
 Shift Rods [C] (see Transmission Installation)

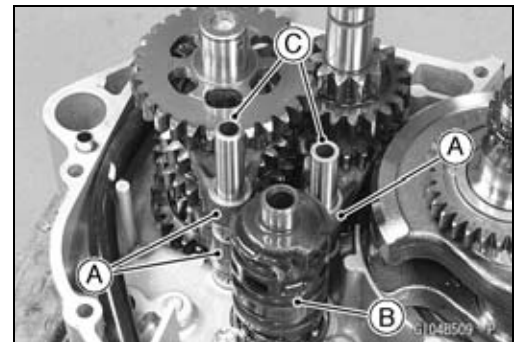

- Assemble the balancer to the crankcase with the punch marks [A] provided on the balancer gear [B] and the driven gear [C] of the crankshaft aligned with each other.

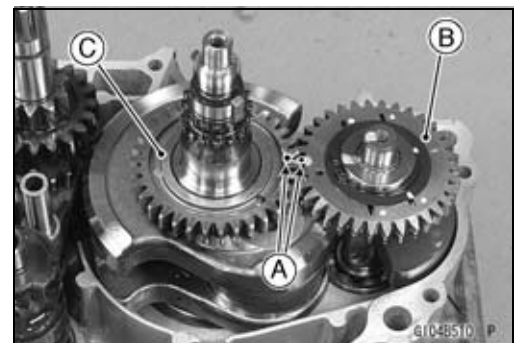

- Install the dowel pins [A].
- Turn the crankshaft to BDC, and install the crankshaft jig [B] between the flywheels opposite the connecting rod big end to protect flywheel alignment as shown.
- If the crankshaft has been removed from the crankcase, install the jig between the crankshaft flywheels before pressing the crankshaft into the left crankcase half.

Special Tool - Crankshaft Jig: 57001-1174

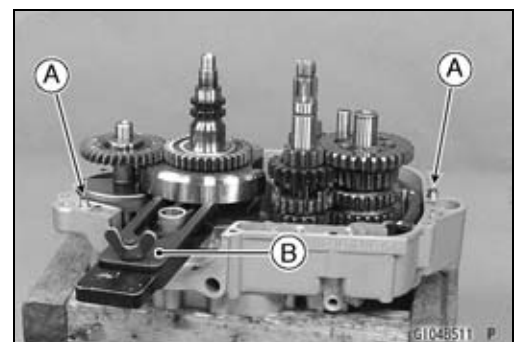

9-12 CRANKSHAFT/TRANSMISSION

Crankcase

- Apply liquid gasket [A] to the mating surfaces of the right crankcase half.

Sealant - Liquid Gasket, TB1216B: 92104-1064

NOTE

- Make the application finish within 20 minutes when the liquid gasket to the mating surface of the crankcase half is applied.
- Moreover fit the case and tighten the case bolts just after finishing the application of the liquid gasket.

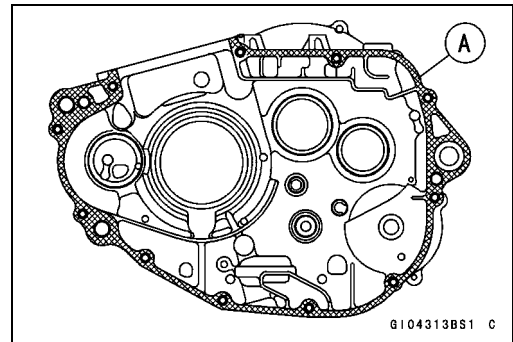

- Tap lightly with a plastic hammer [A] the perimeter of the crankshaft and assemble the right crankcase [B].
- Assemble them with care to keep the right and left crankcase halves in parallel all the time.
- Remove the crankcase jig [C].

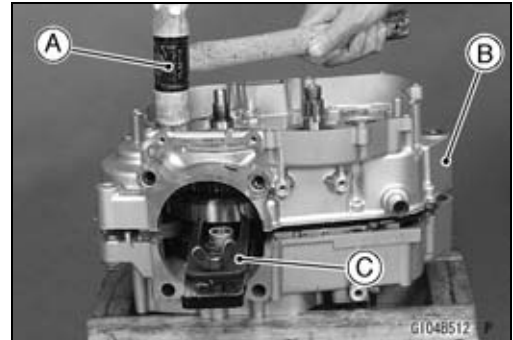

- Tighten the crankcase mounting bolts starting with the ones around the crankshaft, and then the farther ones.

Torque - Crankcase Bolts [A]: 9.8 N·m (1.0 kgf·m, 87 in·lb)

Crankcase Allen Bolts [B]: 12 N·m (1.2 kgf·m, 106 in·lb)

NOTE

- After tightening the crankcase bolts, wipe up the liquid gasket seeping out around the mating surface.

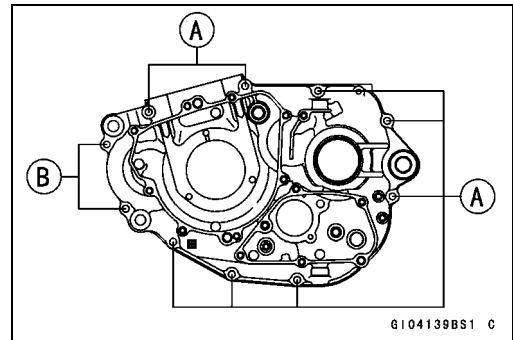

- Check to see that the crankshaft, drive shaft, and output shaft all turn smoothly.
- ★ If the crankshaft will not turn, probably the crankshaft is not centered; tap the end of the crankshaft with a mallet to reposition it.

- Replace the circlip [A] with a new one.
- Install the collar [B] and circlip on the output shaft.

Special Tool - Outside Circlip Pliers: 57001-144

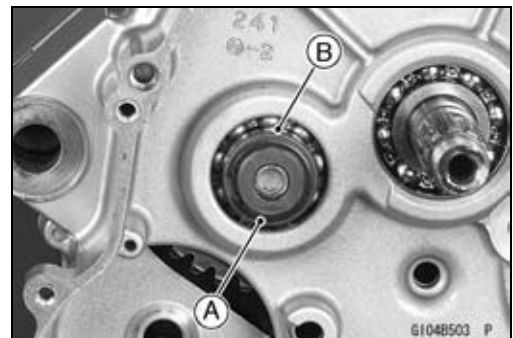

Crankcase

- Install the gear positioning lever [A].
- Fit the each ends [B] of the spring as shown.
- Do not forget to install the washer and spacer [C].
- Tighten:

Torque - Gear Positioning Lever Nut [D]: 9.8 N·m (1.0 kgf·m, 87 in·lb)

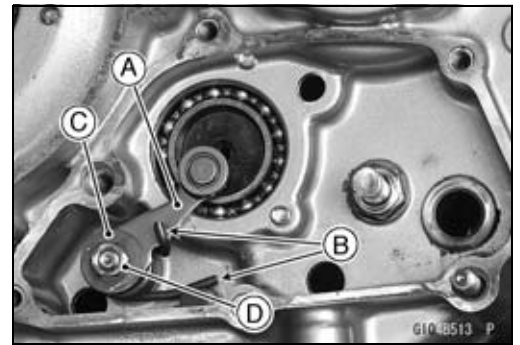

- Install the pin [A] to the shift drum cam [B].
- Install the shift drum cam holder [C] so that the groove [D] fit the pin.

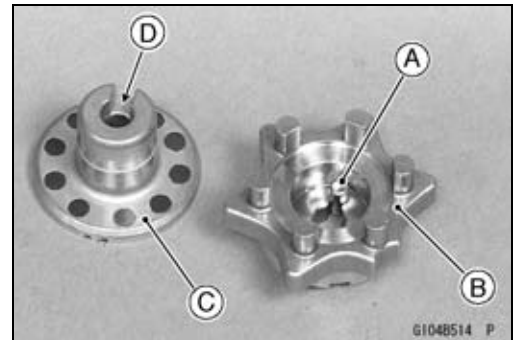

- Install the pin [A] to the shift drum.
- To install the shift drum cam [B], using a screw driver [C] to push down the gear positioning lever [D] toward the bottom of the crankcase.
- Fit the hollow [E] of the shift drum cam on the shift drum pin.

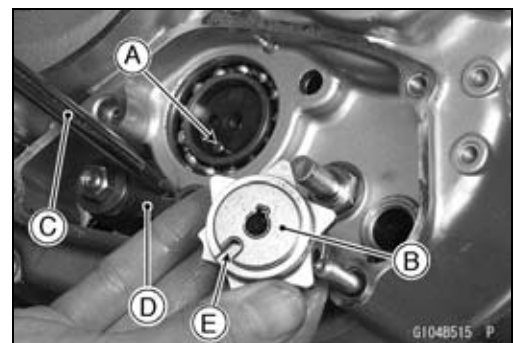

- Apply a non-permanent locking agent to the threads of the shift drum cam holder bolt [A].
- Tighten:

Torque - Shift Drum Cam Holder Bolt: 12 N·m (1.2 kgf·m, 106 in·lb)

- Check to see that gears shift smoothly from 1st to 6th gear, and 6th to 1st while spinning the output shaft.
- Set the shift drum in the neutral position.
- Install the shift shaft assembly (see External Shift Mechanism Installation).



- Replace the O-ring [A] with a new one.
- Apply grease to the inner surface of the output shaft collar [B].
- Insert the collar with notched side [C] facing toward the engine.
- Install the removed parts (see appropriate chapters).



9-14 CRANKSHAFT/TRANSMISSION

Crankshaft/Connecting Rods

Crankshaft Removal

- Split the crankcase, and remove the right crankcase half (see Crankcase Splitting).
- Pull out the shift rod, and take off the shift forks.
- Remove the shift drum.
- Remove the drive shaft and output shaft.
- Remove the balancer.
- Using a press [A], remove the crankshaft [B] from the left crankcase [C].

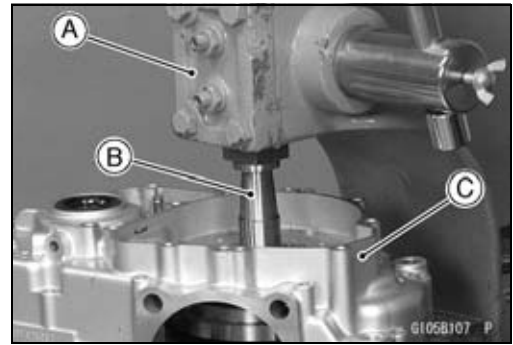

- ★ If the bearings stay on the crankshaft when splitting the crankcase or removing the crankshaft from the left crankcase, remove the bearings from the crankshaft with a bearing puller [A] and adapter [B].

Special Tool - Bearing Puller: 57001-135

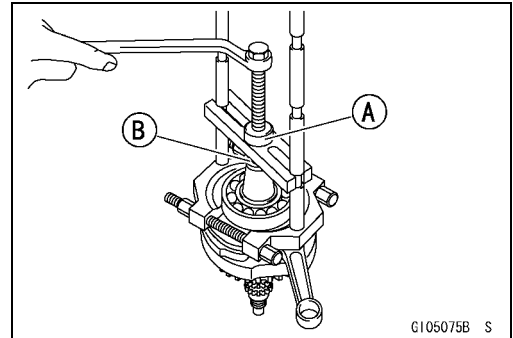

Crankshaft Installation

- If the crankshaft bearings were removed, press them into the crankcase using a bearing driver [A] and press until the bearing bottoms out.

Special Tool - Bearing Driver Set: 57001-1129

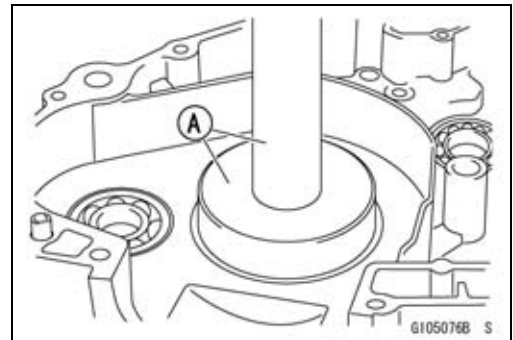

- Set the crankshaft jig [A] onto the crankshaft and press fit it into the crankshaft bearing hole of the left crankcase.
- In doing so, lay the crankshaft jig in the direction of the cylinder so that it does not hit the crankcase.

Special Tool - Crankshaft Jig: 57001-1174

- Apply engine oil to the connecting rod big end bearing.

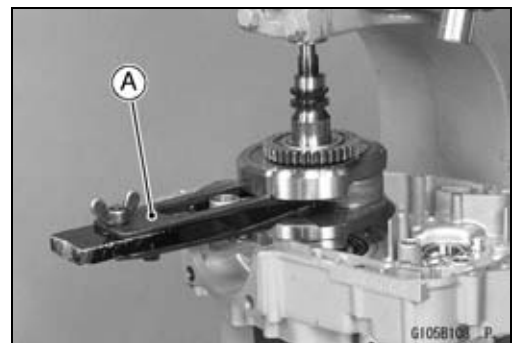

Crankshaft/Connecting Rod Cleaning

- Blow the crankshaft oil holes with compressed air to remove any foreign particles or residue that may have accumulated in the holes.

Crankshaft/Connecting Rods

Connecting Rod Bend Inspection

- Select an arbor of the same diameter as the piston pin and more than 100 mm long, and insert the arbor [A] through the connecting rod small end.
- Set the journal portions [C] of the crankshaft on V blocks [B].
- With the connecting rod held vertically, use a height gauge to measure the difference in the height of the small end arbor above the surface plate over a 100 mm length to determine the amount of connecting rod bend.

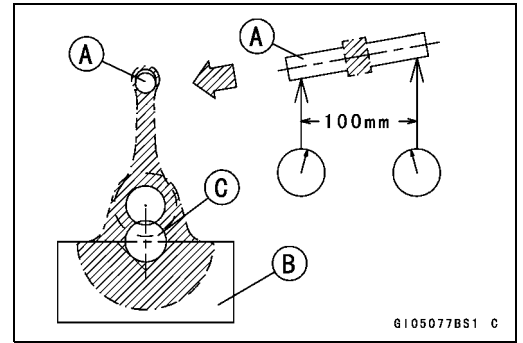

Connecting Rod Bend

Service Limit: 0.2 mm (0.008 in.)

- ★ If connecting rod bend exceeds the service limit, replace the crankshaft assembly with a new one.

Connecting Rod Twist Inspection

- With the journal portions [A] of the crankshaft still on V block [C], hold the connecting rod horizontally and measure the amount that the arbor [B] varies from being paralleled with the surface plate over a 100 mm length of the arbor to determine the amount of connecting rod twist.

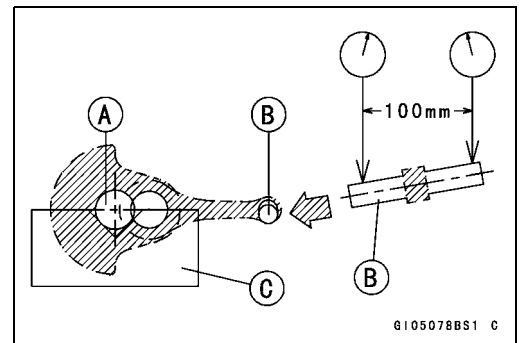

Connecting Rod Twist

Service Limit: 0.2 mm (0.008 in.)

- ★ If connecting rod twist exceeds the service limit, replace the crankshaft assembly with a new one.

Connecting Rod Big End Radial Clearance Inspection

- Set the crankshaft on V blocks, and place a dial gauge [A] against the connecting rod big end.
- Push the connecting rod first towards the gauge and then in the opposite direction [B]. The difference between the two gauge readings is the radial clearance.

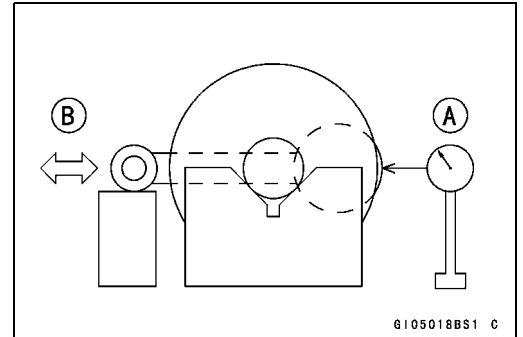

Connecting Rod Big End Radial Clearance

Standard: 0.008 ~ 0.02 mm (0.0003 ~ 0.0008 in.)

Service Limit: 0.07 mm (0.003 in.)

- ★ If radial clearance exceeds the service limit, replace the crankshaft assembly with a new one.

Connecting Rod Big End Side Clearance Inspection

- Measure the side clearance [A] with a thickness gauge.

Connecting Rod Big End Side Clearance

Standard: 0.25 ~ 0.35 mm (0.0098 ~ 0.014 in.)

Service Limit: 0.55 mm (0.022 in.)

- ★ If side clearance exceeds the service limit, the crankshaft assembly must be replaced.

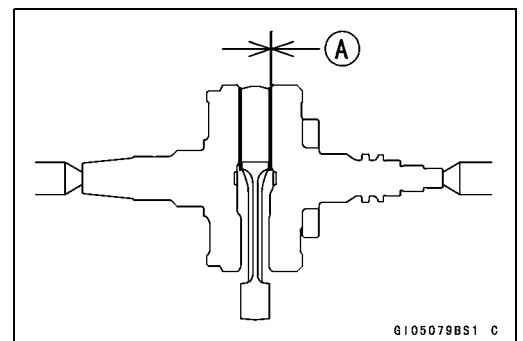

9-16 CRANKSHAFT/TRANSMISSION

Crankshaft/Connecting Rods

Crankshaft Runout Inspection

- Set the crankshaft in a flywheel arrangement jig or on V blocks, and place a dial gauge as shown. Turn the crankshaft slowly. The largest difference in gauge readings (TIR) for each point is taken as crankshaft runout at that point.

10 mm (0.39 in.) [A]

15 mm (0.59 in.) [B]

Crankshaft Runout

Standard: TIR 0.03 mm (0.001 in.) or less

Service Limit: TIR 0.08 mm (0.003 in.)

- ★ When the runout at any point is in excess of the service limit, either change crankshaft assembly or straighten the crankshaft to correct runout.
- First correct runout in the horizontal direction. Tap with a copper hammer to correct the crank [A] that causes crankshaft runout.
- Correct until runout is reduced below the service limit, while checking runout from time to time.
- Next, correct the vertical misalignment by either driving a wedge [A] in between the crank halves or by squeezing them in a vice, depending on the nature of the misalignment.

NOTICE

Do not hammer the crank half at the point [B].

- ★ If flywheel misalignment cannot be corrected by the above method, replace the crankshaft itself.

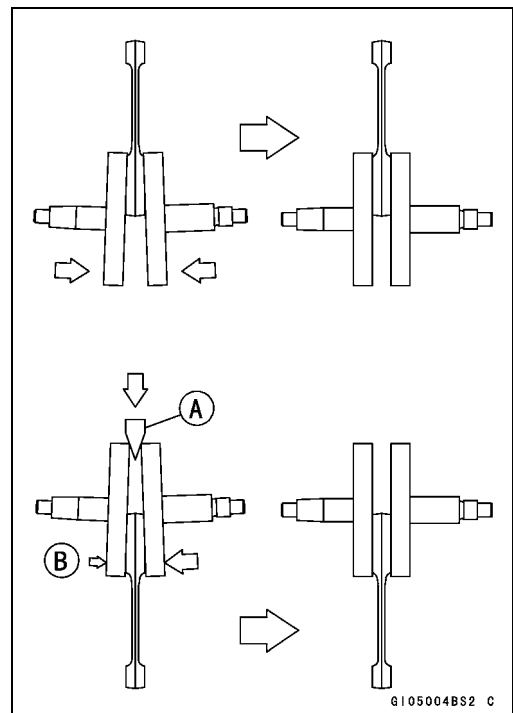
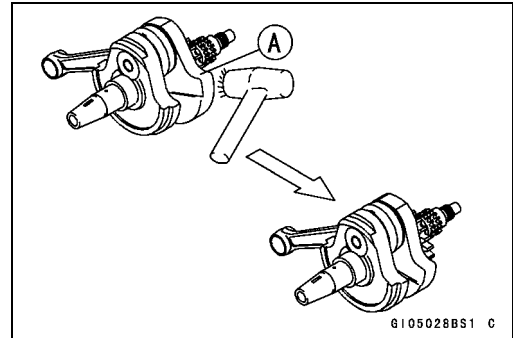
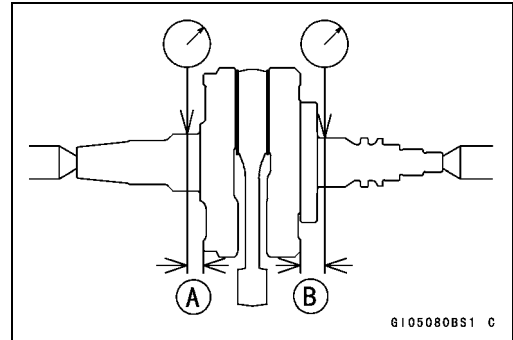

Transmission

Transmission Removal

- Split the crankcase (see Crankcase Splitting).
- Pull off the shift rods [A], and disengage the shift fork guide pins from the shift drum [B].
- Remove:
 - Shift Forks [C]
 - Shift Drum

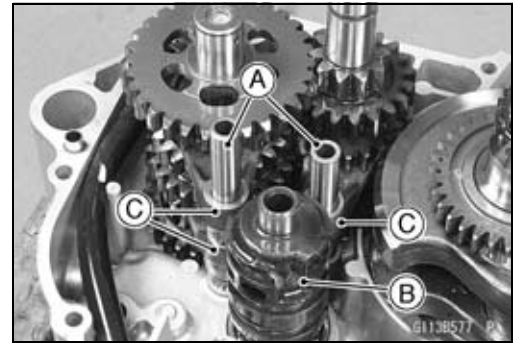

- Turn the crankshaft [A] to position where the crankshaft web does not get in the way of the drive shaft [B], and take out the drive shaft and the output shaft [C] together with their gears meshed.

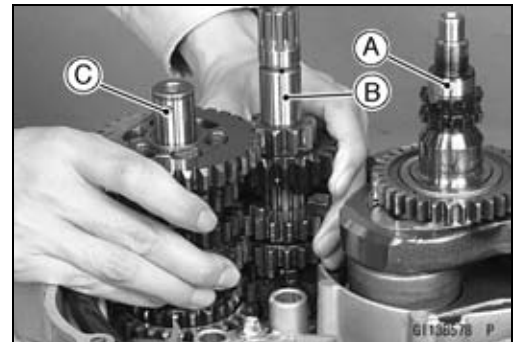

Transmission Installation

- Apply engine oil to the sliding surfaces on the transmission shafts, gears and ball bearings.
- Turn the crankshaft [A] to position where the crankshaft web does not get in the way of the drive shaft [B], engage drive shaft gears and output shaft [C] gears, and set these shafts together into the left crankcase half [D].

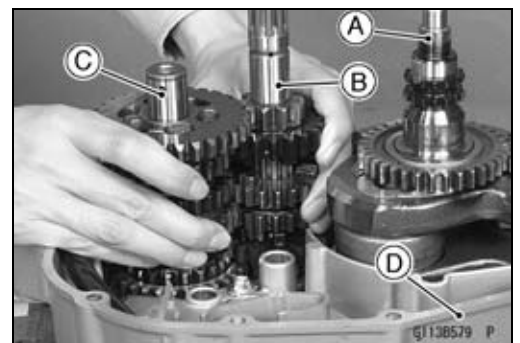

- Apply a little engine oil to the shift fork ears, and fit the shift forks into each gear groove.
- Install the shift fork [A] with shorter ears (3/4th).
- Install the shift drum [B].

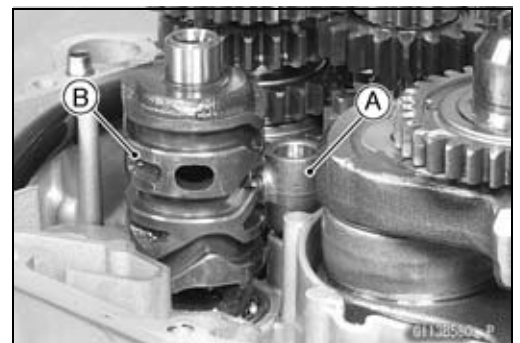

- Set the shift fork that has a guide pin hook on the left side (for the 6th gear) [A].
- Set the shift fork that has a guide pin hook at the center (for the 5th gear) [B].
- Fit the shift fork guide pins into the shift drum grooves.
- Apply a little engine oil to the shift rod, and insert the shift forks.

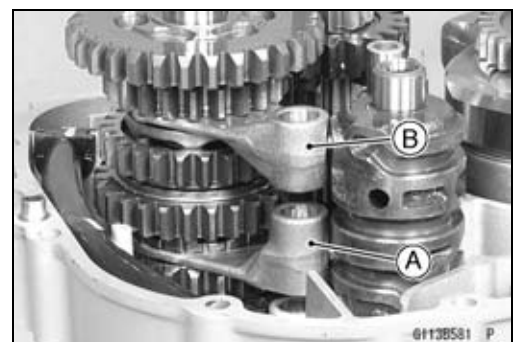

9-18 CRANKSHAFT/TRANSMISSION

Transmission

○The shift forks can be identified by their shapes.

Driveshaft

3/4th gear shift fork [A] ... Shorter ears

Output shaft

6th gear shift fork [B] ... Guide pin goes to left side of the ears

5th gear shift fork [C] ... Guide pin goes to the center of the ears

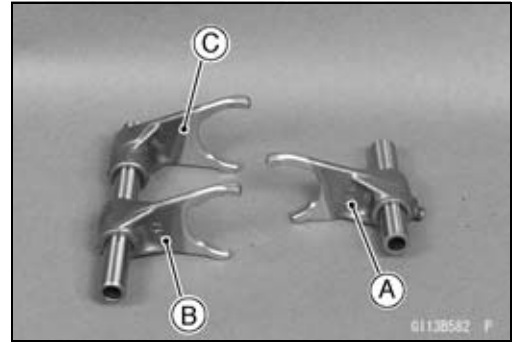

● Assemble the crankcase (see Crankcase Assembly).

Transmission Disassembly

- Remove the transmission (see Transmission Removal).
- Using the circlip pliers, remove the circlips, and disassemble the transmission.

Special Tool - Outside Circlip Pliers: 57001-144

Transmission Assembly

- Apply plenty of engine oil to the transmission shafts, gears and ball bearings.
- Replace any circlips that were removed with new ones.
- Install the circlips [A] so that the opening [B] of it is aligned with spline grooves [C].

Special Tool - Outside Circlip Pliers: 57001-144

- Drive shaft gears are for the 1st to 6th gears in order from the smallest to the largest in outer diameter. Assemble in order as illustrated in the figure below with attention paid to the direction of assembling.
- Output shaft gears are for the 1st to 6th gears in order from the largest to the smallest in outer diameter. Assemble in order as illustrated in the figure below with attention paid to the direction of assembling.
- Install the 3rd/4th gear bushings [A] onto the output shaft with their oil holes [B] aligned.

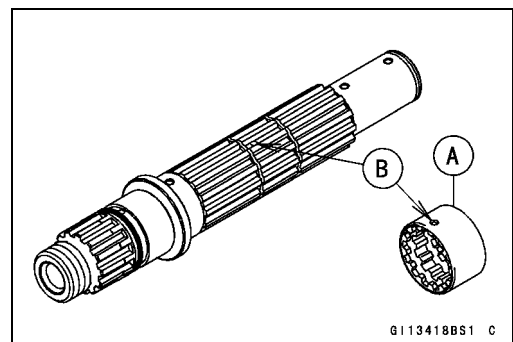
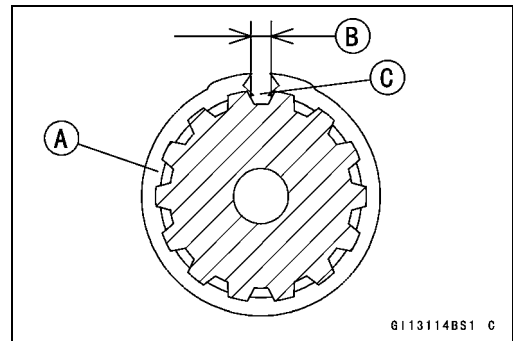

Transmission

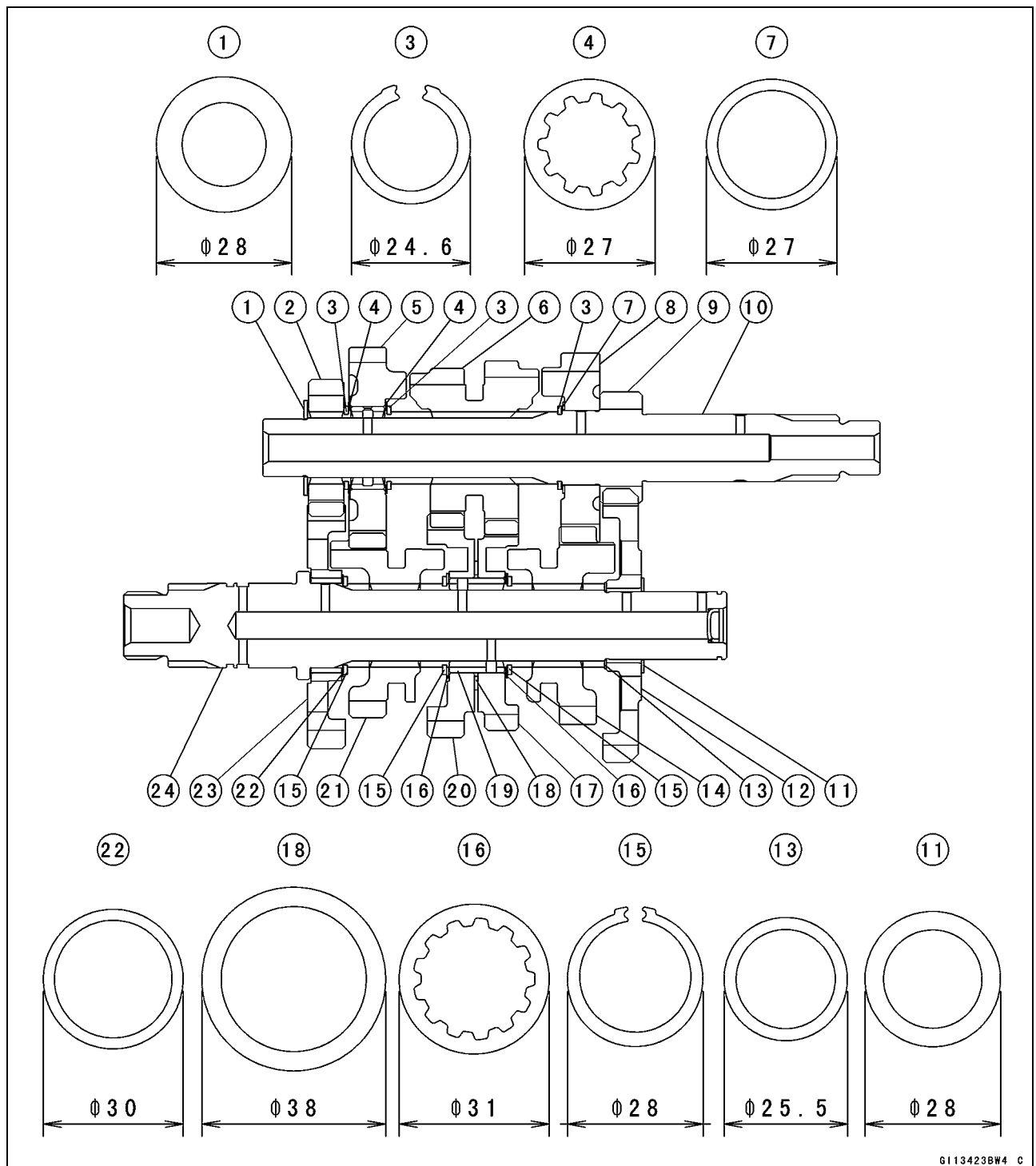

G113423BW4 C

- | | | |
|---------------------------|--------------------------|--------------------|
| 1. Washer (φ28) | 9. 1st Gear (10T) | 17. 4th Gear (25T) |
| 2. 2nd Gear (15T) | 10. Drive Shaft | 18. Washer (φ38) |
| 3. Circlip | 11. Washer (φ28) | 19. Bushing |
| 4. Toothed Washer (φ27) | 12. 1st Gear (30T) | 20. 3rd Gear (27T) |
| 5. 6th Gear (21T) | 13. Washer (φ25.5) | 21. 6th Gear (20T) |
| 6. 3rd/4th Gear (18T/20T) | 14. 5th Gear (21T) | 22. Washer (φ30) |
| 7. Washer (φ27) | 15. Circlip | 23. 2nd Gear (30T) |
| 8. 5th Gear (20T) | 16. Toothed Washer (φ31) | 24. Output Shaft |

● After assembling, check that each gear spins or slides freely on the transmission shafts without binding.

9-20 CRANKSHAFT/TRANSMISSION

Transmission

Shift Fork Bending Inspection

- Visually inspect the shift forks, and replace any fork that is bent. A bent fork could cause difficulty in shifting or allow the transmission to jump out of gear under power. 90° [A]

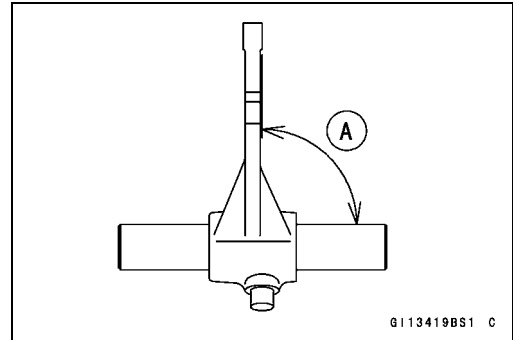

Shift Fork/Gear Groove Wear Inspection

- Measure the thickness of the shift fork ears [A], and measure the width [B] of the shift fork grooves in the gears.

Shift Fork Ear Thickness

Standard: 4.9 ~ 5.0 mm (0.19 ~ 0.20 in.)

Service Limit: 4.8 mm (0.19 in.)

Gear Shift Fork Groove Width

Standard: 5.05 ~ 5.15 mm (0.199 ~ 0.203 in.)

Service Limit: 5.2 mm (0.20 in.)

- ★ If the thickness of a fork ear is less than the service limit, the shift fork must be replaced. If the gear groove is worn over the service limit, the gear must be replaced.

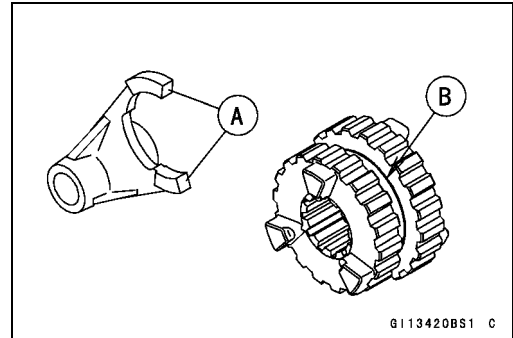

Shift Fork Guide Pin/Drum Groove Wear Inspection

- Measure the diameter of each shift fork guide pin [B], and measure the width [A] of each shift drum groove.

Shift Fork Guide Pin Diameter

Standard: 5.9 ~ 6.0 mm (0.23 ~ 0.24 in.)

Service Limit: 5.8 mm (0.23 in.)

Shift Drum Groove Width

Standard: 6.05 ~ 6.20 mm (0.238 ~ 0.244 in.)

Service Limit: 6.3 mm (0.25 in.)

- ★ If the guide pin diameter is less than the service limit, replace the shift forks. If the shift drum groove is worn over the service limit, the drum must be replaced.

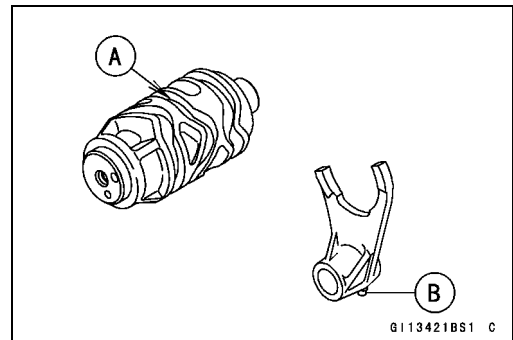

Gear Dog and Gear Dog Hole Damage Inspection

- Visually inspect the gear dogs [A] and gear dog holes [B].
- ★ Replace any damaged gears or gears with their dogs or dog holes worn excessively.

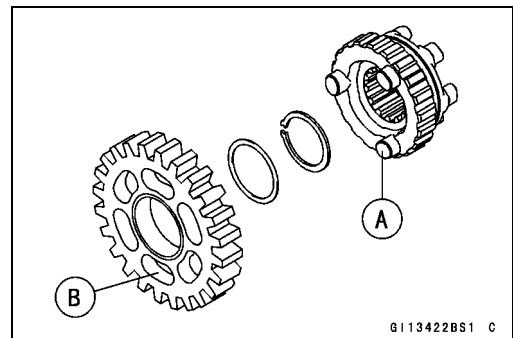

Starter Motor Clutch/Torque Limiter

Starter Motor Clutch Removal/Installation

- Refer to the Alternator Rotor Removal and Installation in the Electrical System chapter.

Starter Motor Clutch Disassembly

- Remove the alternator rotor (see Alternator Rotor Removal in the Electrical System chapter).
- Unscrew the bolts [A], and remove the one-way clutch assembly [B] from the alternator rotor [C].
- Hold firmly so that you may not damage the alternator rotor.

Special Tools - Grip: 57001-1591
Rotor Holder: 57001-1723

- Pull out the one-way clutch from the coupling.



Starter Motor Clutch Assembly

- Be sure to install the one-way clutch so that the flange [A] of it fits between the coupling [B] and alternator rotor [C].
- Apply a non-permanent locking agent to the threads of the starter motor clutch bolts [D], and tighten them.

Torque - Starter Motor Clutch Bolts: 12 N·m (1.2 kgf·m, 106 in·lb)

Special Tools - Grip: 57001-1591
Rotor Holder: 57001-1723

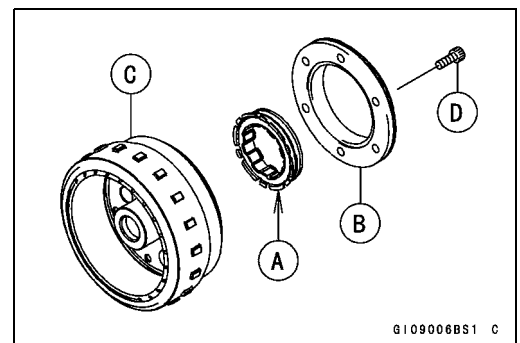

Starter Motor Clutch Inspection

- Remove the alternator cover (see Alternator Cover Removal in the Electrical System chapter).
- Turn the starter motor clutch gear [A] by hand. The starter motor clutch gear should turn clockwise [B] freely, but should not turn counterclockwise [C].
- ★ If the clutch does not operate as it should or if it makes noise, remove and disassemble the starter clutch, and visually inspect the clutch parts.
- ★ If there is any worn or damaged part, replace it.

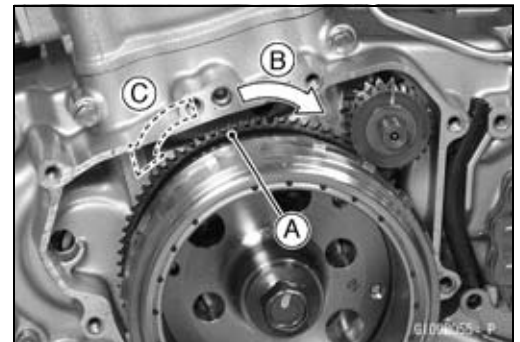

NOTE

○ Examine the starter motor clutch gear as well. Replace it if it is worn or damaged.

Torque Limiter Removal

- Unscrew the bolts [A] and remove the torque limiter cover [B].

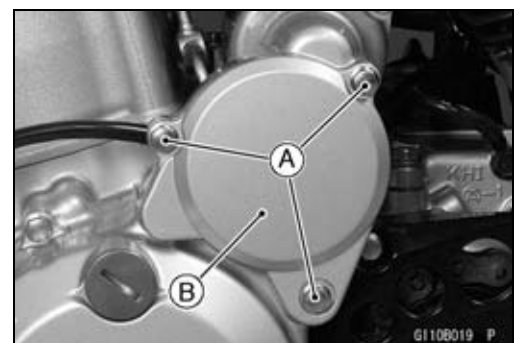

9-22 CRANKSHAFT/TRANSMISSION

Starter Motor Clutch/Torque Limiter

- Remove the torque limiter [A].
- There are washers set on both sides of the torque limiter.

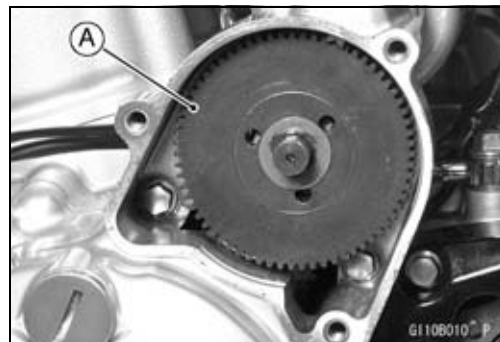

Torque Limiter Inspection

- Remove the torque limiter [A] (see Torque Limiter Removal) and visually inspect it.
- ★ If the limiter has wear, discoloration, or damage, replace it.

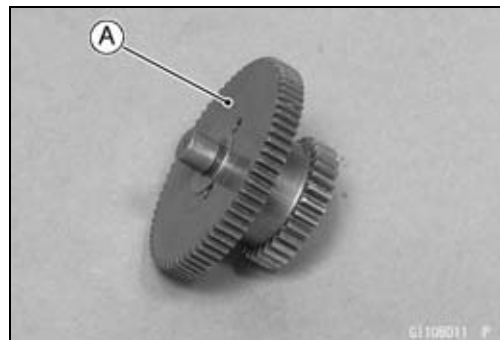

Torque Limiter Installation

- Apply molybdenum disulfide grease to the torque limiter and shafts and install it,
- Set washers [A] on both sides of the torque limiter.
- Install the starter motor gear cover.

Torque - Torque Limiter Cover Bolts: 9.8 N·m (1.0 kgf·m, 87 in·lb)

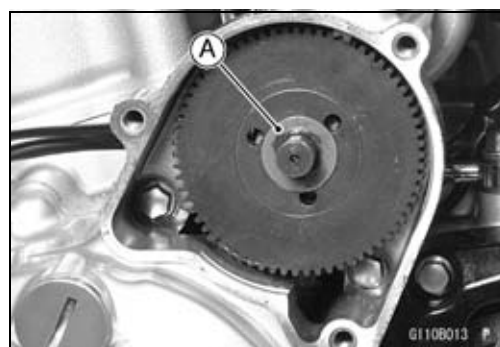

Primary Gear

Primary Gear Removal

- Remove:
 - Right Engine Cover (see Right Engine Cover Removal in the Clutch chapter)
 - Oil Pump (see Oil Pump Removal in the Engine Lubrication System chapter)
- Loosen the clutch hub nut [A] (see Clutch Removal in the Clutch chapter).
- Remove the primary gear nut [B].
- Remove the clutch (see Clutch Removal in the Clutch chapter).
- Remove the spring washer, primary gear [C] and woodruff key.



NOTE

○Use the gear holder [D] to prevent the crankshaft from rotating.

Special Tool - Gear Holder: 57001-1602

Primary Gear Installation

- Set the woodruff key [A] securely between the primary gear [B] and the crankshaft.

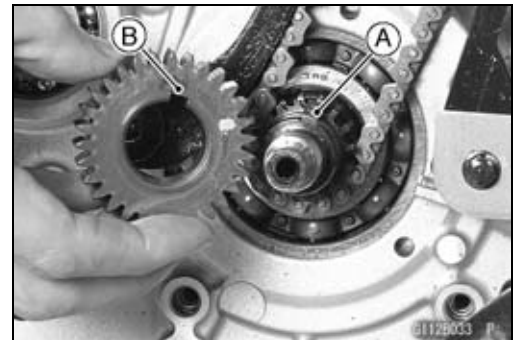

- Set the washer [A] with its concaved side [B] facing inward.

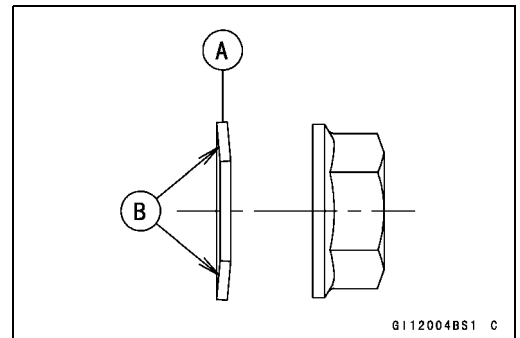

- Install the clutch (see Clutch Installation in the Clutch chapter).
- Tighten:
 - Torque - Primary Gear Nut [A]: 98 N·m (10 kgf·m, 72 ft·lb)**

NOTE

○Use the gear holder [B] to prevent the crankshaft from rotating.

Special Tool - Gear Holder: 57001-1602

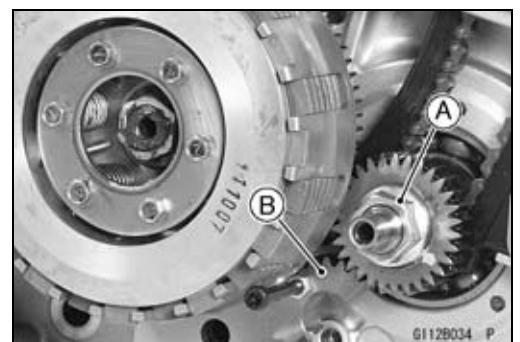

9-24 CRANKSHAFT/TRANSMISSION

Balancer

Balancer Removal

- Split the crankcase (see Crankcase Splitting).
- Remove the balancer from the left crankcase with the punch marks [A] provided on the balancer gear [B] and the driven gear [C] of the crankshaft aligned with each other.

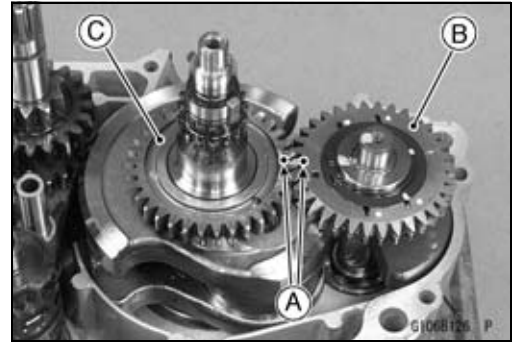

Balancer Disassembly

- Remove the balancer gear [A] from the balancer shaft [B].
- Tap the balancer gear side end of the shaft lightly with a plastic hammer to detach the balancer gear.

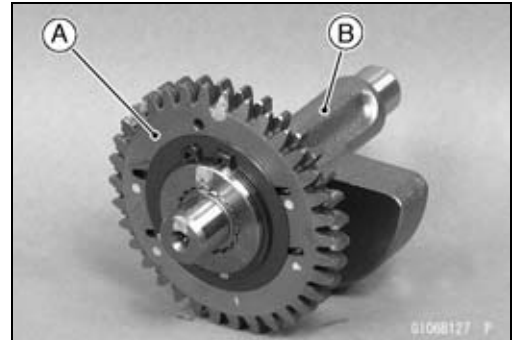

Balancer Assembly

- Replace the circlip [A] with a new one, if removed.
- Put an appropriate pin [B] through the upper and lower balancer gear holes to align the upper and lower balancer gears correctly.
- Install the balancer gear [C] so that the balancer gear punch mark [D] and balancer shaft punch mark [E] align.

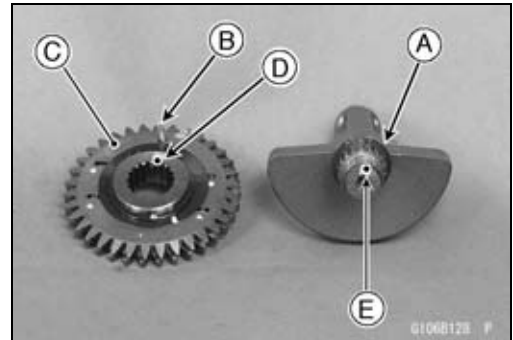

Balancer Installation

- Assemble the balancer to the crankcase with the punch marks [A] provided on the balancer gear [B] and the driven gear [C] of the crankshaft aligned with each other.
- Pull out the pin [D].

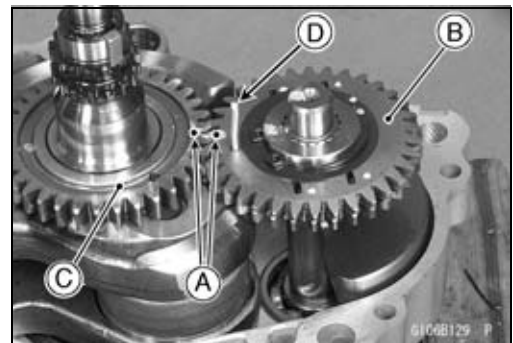

External Shift Mechanism

Shift Pedal Removal

- Unscrew the mounting bolts [A] and remove the shift pedal [B].

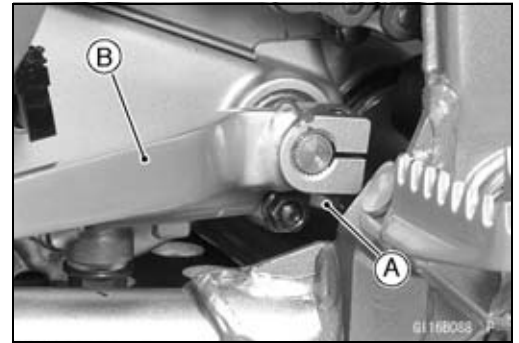

Shift Pedal Installation

- Install the shift pedal, and tighten the mounting bolt.
Torque - Shift Pedal Bolt: 9.8 N·m (1.0 kgf·m, 87 in·lb)

External Shift Mechanism Removal

- Remove:
 - Engine Sprocket (see Engine Sprocket Removal in the Final Drive chapter)
 - Shift Pedal (see Shift Pedal Removal)
 - Bolts [A]
 - Plate [B]
 - Guard [C]

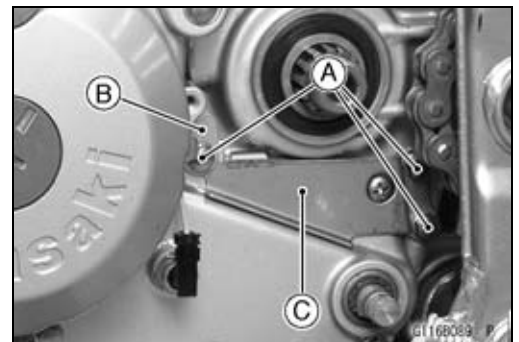

- Remove:
 - Neutral Switch Lead Connector [A]
 - Bolts [B]
 - Nut [C]
 - Screw [D]

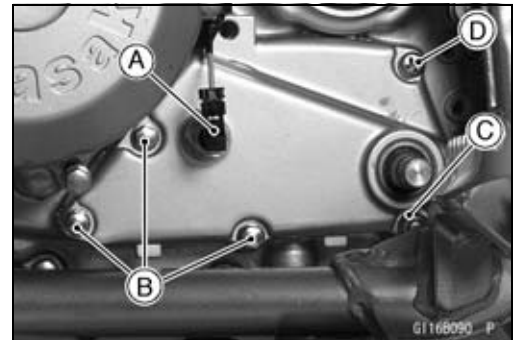

- Remove the shift mechanism cover [A] until contact it to the frame.



9-26 CRANKSHAFT/TRANSMISSION

External Shift Mechanism

- Set the shift mechanism cover [A] to the shift shaft as shown.
- While pushing the shift mechanism lever [B] backward, pull out the shift shaft [C] to remove the shift mechanism cover together with the shift shaft assembly.

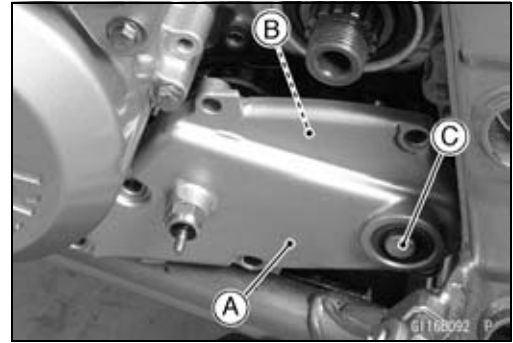

- Remove:
 - Shift Drum Cam Holder Bolt [A]
 - Shift Drum Cam Holder [B]

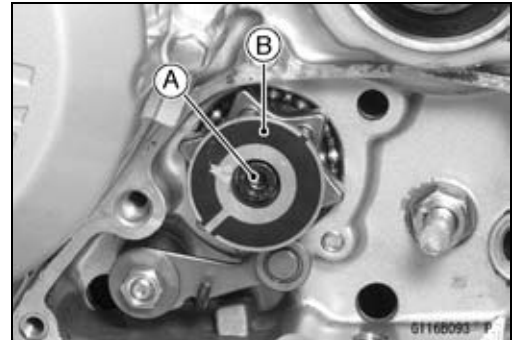

- While pushing down the gear positioning lever [A], remove the shift drum cam [B].

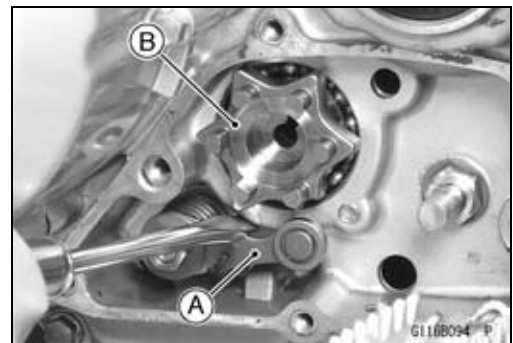

- Remove:
 - Nut [A]
 - Gear Positioning Lever [B]
 - Spring [C]

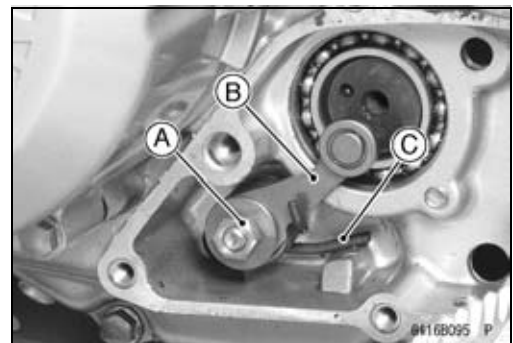

External Shift Mechanism Installation

- Install:
 - Spring [A]
 - Washer [B]
 - Gear Positioning Lever [C]
 - Spacer [D]
- Tighten:
 - Torque - Gear Positioning Lever Nut [E]: 9.8 N·m (1.0 kgf·m, 87 in·lb)

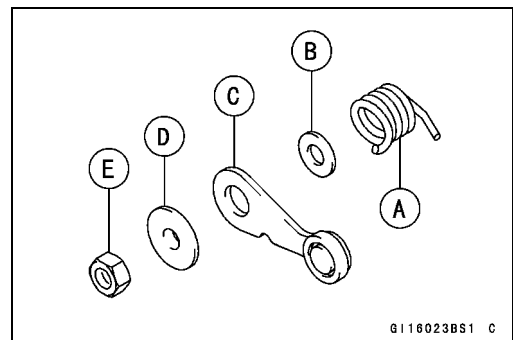

External Shift Mechanism

- Install the pin [A].
- Use a screw driver to push down the gear positioning lever [B] and set the shift drum cam [C] so that the groove [D] of the shift drum cam fit the pin.

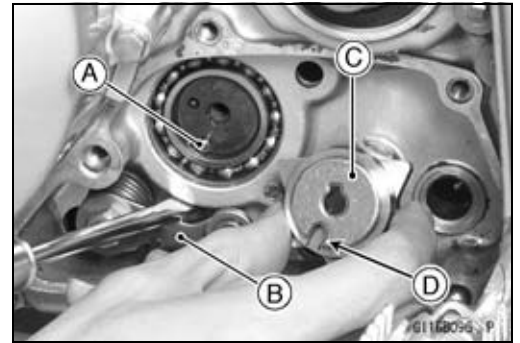

- Install the pin [A] to the shift drum cam.
- Install the shift drum cam holder [B] so that the groove [C] of the holder fit the pin.

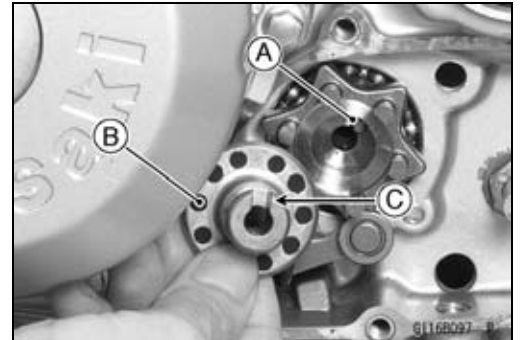

- Apply a non-permanent locking agent to the threads of the shift drum cam holder bolt [A] and tighten it.

Torque - Shift Drum Cam Holder Bolt: 12 N·m (1.2 kgf·m, 106 in·lb)

- Install the dowel pins [B].
- Replace the gasket [C] with a new one.

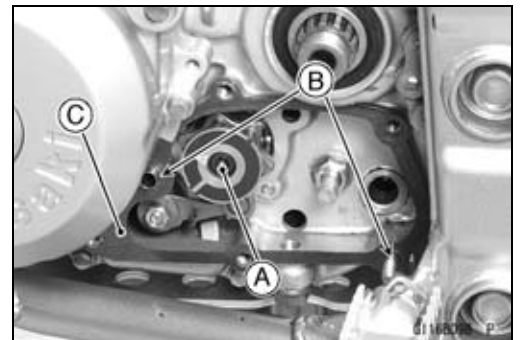

- Apply grease to the oil seal of the external shift mechanism cover.
- Insert the shift shaft assembly [A] to the external shift mechanism cover [B].
- Install the washer [C] to the shift shaft.

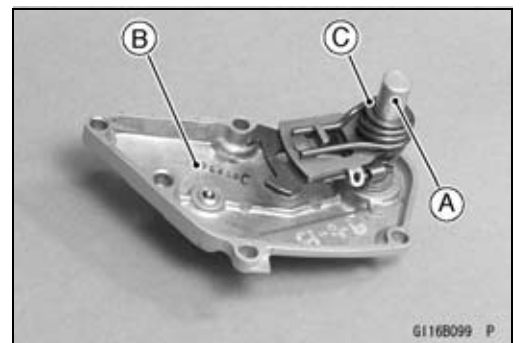

- While pushing the shift mechanism lever [A] backward, install the shift shaft assembly [B] together with the external shift mechanism cover [C].

Torque - External Shift Mechanism Cover Bolts and Nut: 9.8 N·m (1.0 kgf·m, 87 in·lb)

External Shift Mechanism Cover Screw: 5.2 N·m (0.53 kgf·m, 46 in·lb)

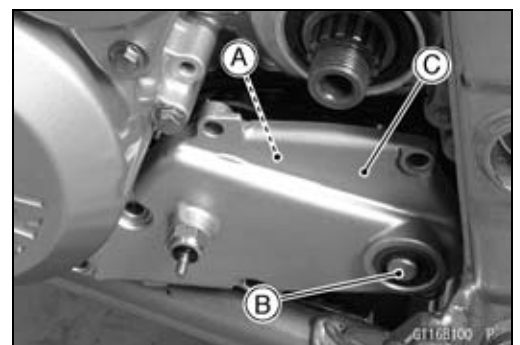

9-28 CRANKSHAFT/TRANSMISSION

External Shift Mechanism

External Shift Mechanism Inspection

- Inspect the shift shaft [A] for any damage.
- ★ If the shaft is bent, repair or replace it.
- ★ If the spring [B] or shift pedal return spring [C] are damaged, replace the spring.
- ★ If the shift mechanism arm [D] is damaged, replace the assembly.

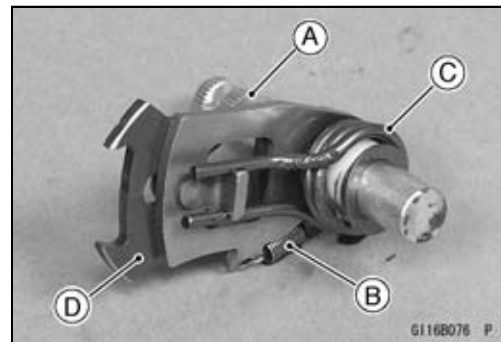

- Check that the return spring pin [A] is not loose.
- ★ If it is loose, unscrew it, then apply a non-permanent locking agent, and tighten it.

Torque - Shift Shaft Return Spring Pin: 37 N·m (3.8 kgf·m, 27 ft·lb)

- Check the gear positioning lever [B] and spring [C] for any damage.
- ★ If it shows any signs of damage, replace it with a new one.

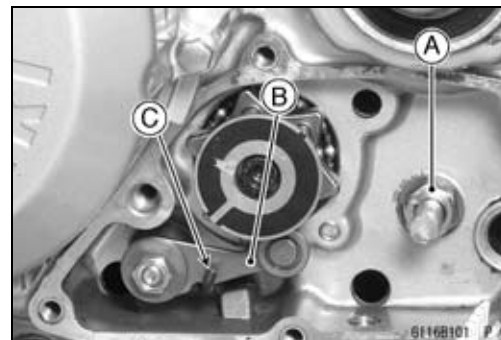

Bearing, Oil seal

Bearing Replacement

NOTICE

Do not remove the ball bearings unless it is necessary. Removal may damage them.

- Using a press or puller, remove the ball bearing.

NOTE

○ *In the absence of the above mentioned tools, satisfactory results may be obtained by heating the case to approximately 93°C (200°F) max., and tapping the bearing in or out lightly.*

NOTICE

Do not heat it with a torch. This will warp the case. Soak the case in engine oil and heat the oil.

- Using a press and the bearing driver set [A], install the new bearing or outer race until it stops at the bottom of its housing.

Special Tool - Bearing Driver Set: 57001-1129

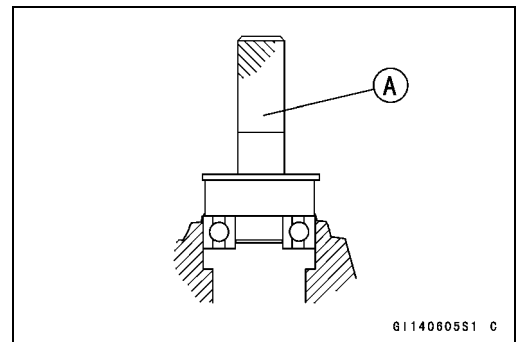

Bearings Inspection

NOTICE

Do not remove the ball bearings for inspection. Removal may damage them.

- Check the ball bearings.
- Since the ball bearing is made to extremely close tolerances, the wear must be judged by feel rather than measurement. Wash the bearing with a high flash-point solvent, dry it (do not spin it while it is dry), and apply engine oil.
- Spin [A] the bearing to check its condition.
- ★ If the bearing is noisy, does not spin smoothly, or has any damage, replace it.
- Check the needle bearings.
- The rollers in a bearing normally wear very little, and wear is difficult to measure. Instead of measuring, inspect the bearing for abrasion, color change, other damage.
- ★ If any anomalies are found in the needle bearing, replace it with a new one.

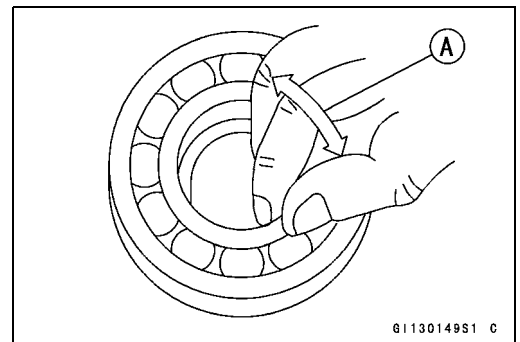

Oil Seal Inspection

- Inspect the oil seals.
- ★ Replace it if the lips are misshapen, discolored (indicating that the rubber has deteriorated), hardened or otherwise damaged.

Wheels/Tires

Table of Contents

Exploded View	10-2
Specifications	10-4
Special Tools	10-6
Wheels (Rims).....	10-7
Front Wheel Removal	10-7
Front Wheel Installation	10-7
Rear Wheel Removal.....	10-8
Rear Wheel Installation.....	10-9
Wheel Inspection	10-10
Spoke Inspection	10-10
Rim Inspection	10-11
Axle Inspection.....	10-11
Tires.....	10-12
Air Pressure Inspection/Adjustment.....	10-12
Tire Inspection	10-12
Tire Removal.....	10-12
Tire Installation.....	10-13
Hub Bearing.....	10-15
Hub Bearing Removal.....	10-15
Hub Bearing Installation.....	10-16
Hub Bearing Inspection.....	10-16
Hub Bearing Lubrication	10-16

10-2 WHEELS/TIRES

Exploded View

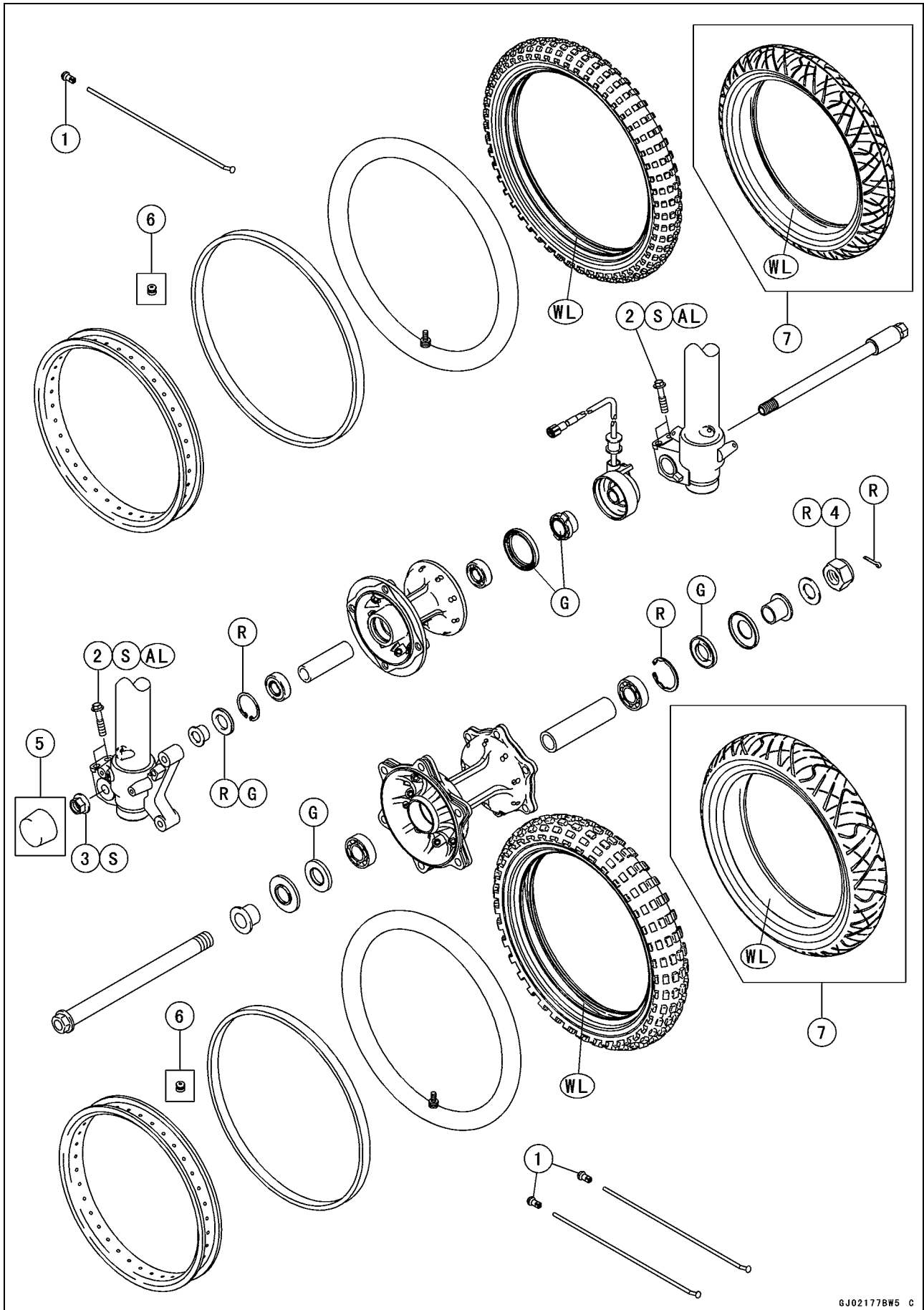

Exploded View

No.	Fastener	Torque			Remarks
		N·m	kgf·m	ft·lb	
1	Spoke Nipples	4.0	0.41	35 in·lb	
2	Front Axle Clamp Bolts	20	2.0	15	AL, S
3	Front Axle Nut	88	9.0	65	S
4	Rear Axle Nut	110	11.2	81.1	R

5. BR and EUR Models

6. KLX250S Model

7. KLX250V Model

AL: Tighten the two clamp bolts alternately two times to ensure even tightening torque.

G: Apply grease.

R: Replacement Parts

S: Follow the specified tightening sequence.

WL: Apply soap and water solution, or rubber lubricant.

10-4 WHEELS/TIRES

Specifications

Item	Standard	Service Limit
Wheels (Rims)		
Rim Runout:		
Axial:		
KLX250S	TIR 0.7 mm (0.028 in.) or less	TIR 2.0 mm (0.08 in.)
KLX250V	TIR 0.8 mm (0.031 in.) or less	TIR 2.0 mm (0.08 in.)
Radial:		
KLX250S	TIR 1.0 mm (0.039 in.) or less	TIR 2.0 mm (0.08 in.)
KLX250V	TIR 1.2 mm (0.047 in.) or less	TIR 2.0 mm (0.08 in.)
Axle Runout/100 mm (3.94 in.)	TIR 0.03 mm (0.001 in.) or less	TIR 0.2 mm (0.008 in.)
Rim Size:		
Front:		
KLX250S	21 × 1.60	---
KLX250V	17 × 3.00	---
Rear:		
KLX250S	18 × 2.15	---
KLX250V	17 × 4.00	---
Tires		
Air Pressure (When Cold):		
Front:		
KLX250S	150 kPa (1.5 kgf/cm ² , 22 psi)	---
KLX250V	200 kPa (2.0 kgf/cm ² , 29 psi)	---
Rear:		
KLX250S	Up to 97.5 kg (215 lb) load: 150 kPa (1.5 kgf/cm ² , 22 psi) 97.5 ~ 181 kg (215 ~ 399 lb) load: 175 kPa (1.75 kgf/cm ² , 25 psi)	---
KLX250V	225 kPa (2.25 kgf/cm ² , 33 psi)	---
Tread Depth:		
Front:		
KLX250S	7.8 mm (0.31 in.)	2 mm (0.08 in.)
KLX250V	4.4 mm (0.17 in.)	1 mm (0.04 in.)
Rear:		
KLX250S	11.8 mm (0.464 in.)	2 mm (0.08 in.)
KLX250V	6.5 mm (0.26 in.)	2 mm (0.08 in.) (Up to 130 km/h) 3 mm (0.12 in.) (Over 130 km/h)
Standard Tires:	Make, Type	Size
Front:		
KLX250S	DUNLOP D605FG	3.00-21 51P
KLX250V	IRC RX-01F	110/70-17M/C 54S
Rear:		
KLX250S	DUNLOP D605G	4.60-18 63P
KLX250V	IRC RX-01R	130/70-17M/C 62S

Specifications

 WARNING

Some replacement tires may adversely affect handling and cause an accident resulting in serious injury or death. To ensure proper handling and stability, use only the recommended standard tires for replacement, inflated to the standard pressure.

10-6 WHEELS/TIRES

Special Tools

Inside Circlip Pliers:
57001-143

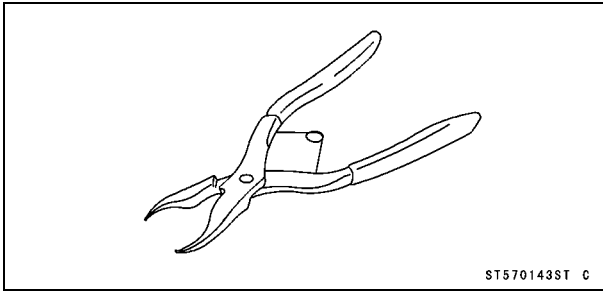

Rim Protector:
57001-1063

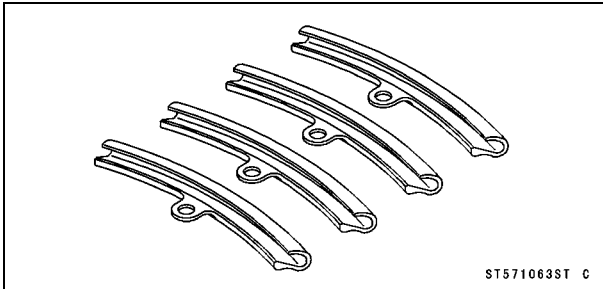

Bead Breaker Assembly:
57001-1072

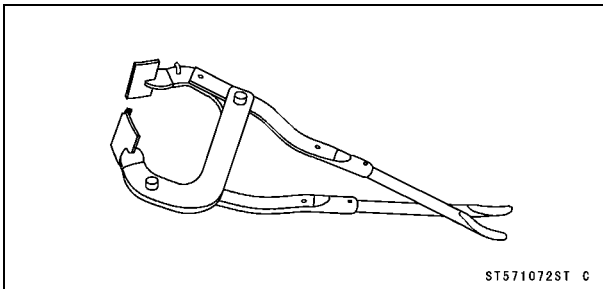

Bearing Driver Set:
57001-1129

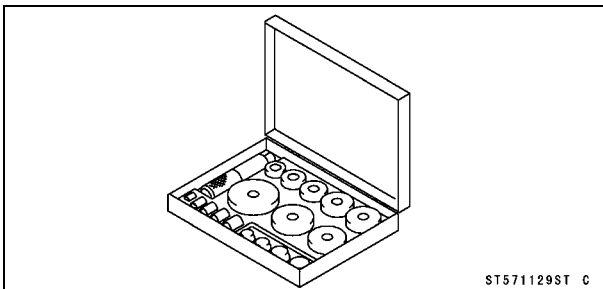

Jack:
57001-1238

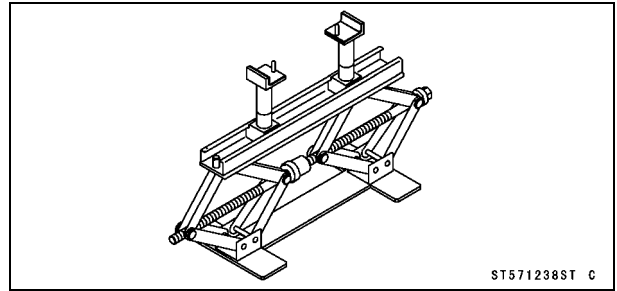

Bearing Remover Head, $\phi 15 \times \phi 17$:
57001-1267

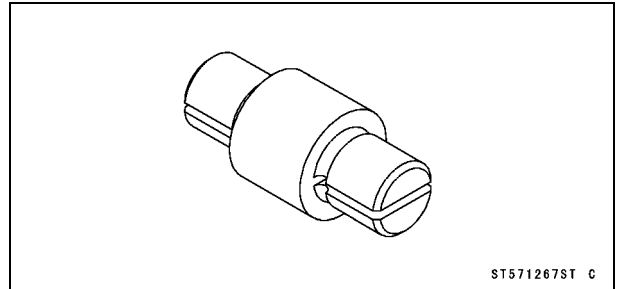

Bearing Remover Head, $\phi 20 \times \phi 22$:
57001-1293

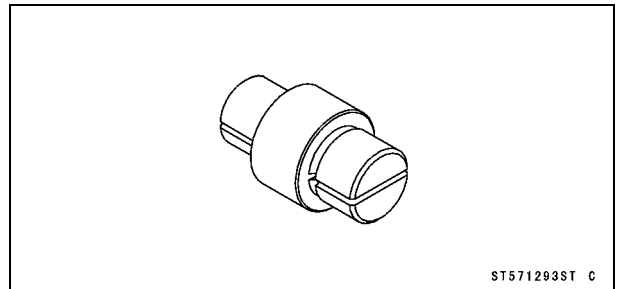

Bearing Remover Shaft, $\phi 13$:
57001-1377

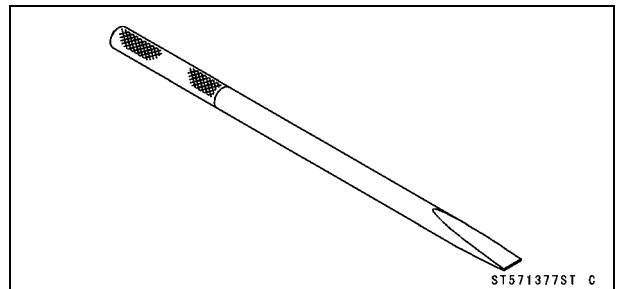

Wheels (Rims)

Front Wheel Removal

- Remove the front axle nut cap (EUR model).
- Remove the front axle nut [A].
- Remove the front axle clamp bolts [B].
- Raise the front wheel off the ground with jack.

Special Tool - Jack: 57001-1238

- Pull out the axle to the right and drop the front wheel out of the forks.

NOTICE

Do not lay the front wheel on the ground with the disc facing down. This can damage or warp the disc. Place blocks under the wheel so that the disc does not touch the ground.

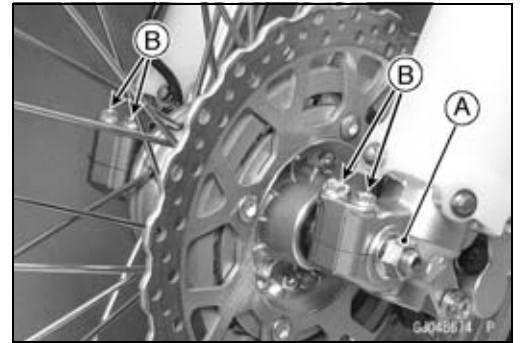

Front Wheel Installation

- Install the speed sensor rotor to the front hub (see Speed Sensor Installation in the Electrical System chapter).
- Apply grease to the seal lips.
- Install the collar [A] on the left side of the front hub [B].

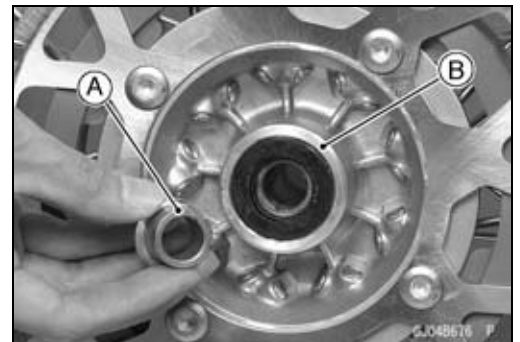

- Position the stopper [A] on the speed sensor to the upper side of the right fork leg as shown.
- Insert the front axle [B] from the right side until it bottoms out.

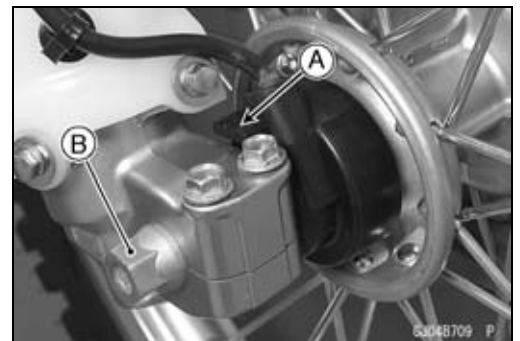

- While holding the front axle, tighten the front axle nut [A].
- Install the left front axle clamp bolts [B], and tighten them.

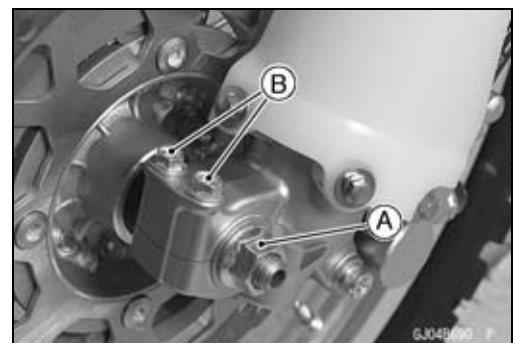

10-8 WHEELS/TIRES

Wheels (Rims)

- Pump the front fork up and down [A] 4 or 5 times to all on the right front fork leg to seat on the front axle before tightening the front axle clamp bolts.

NOTE

○ Do not stop motorcycle moving forward with the front brake. Put a block [B] in front of the front wheel to stop moving.

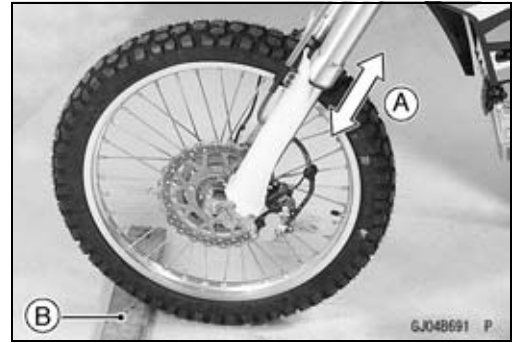

- Tighten:

Torque - Front Axle Nut [A]: 88 N·m (9.0 kgf·m, 65 ft·lb)
Front Axle Clamp Bolts [B]: 20 N·m (2.0 kgf·m, 15 ft·lb)

NOTE

○ Tighten the two clamp bolts alternately two times to ensure even tightening torque.

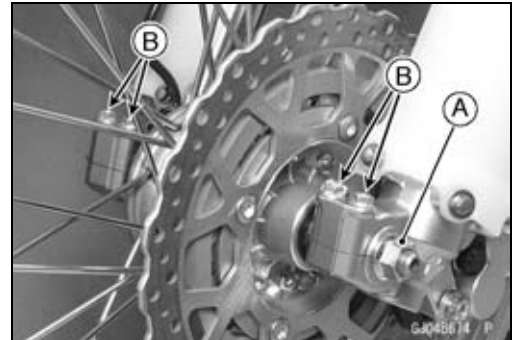

- Install the front axle nut cap (EUR model).
- Check the front brake effectiveness (see Brake Operation Inspection in the Periodic Maintenance chapter).

⚠ WARNING

After servicing, it takes several applications of the brake lever before the brake pads contact the disc, which could result in increased stopping distance and cause an accident resulting in injury or death. Do not attempt to ride the motorcycle until a firm brake lever is obtained by pumping the lever until the pads are against the disc.

Rear Wheel Removal

- Remove the cotter pin [A] and loosen the rear axle nut [B].
- Raise the rear wheel off the ground with jack.

Special Tool - Jack: 57001-1238

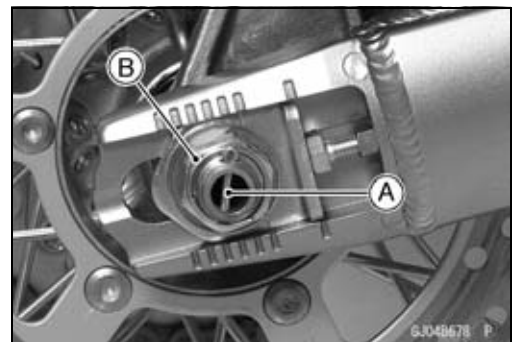

Wheels (Rims)

- Squeeze the front brake lever, and hold it with a band [A] to prevent the motorcycle from running forward.

⚠ WARNING

Motorcycle may fall over unexpectedly resulting in an accident or injury. Be sure to hold the front brake when removing the rear wheel.



- Remove:
 - Rear Axle Nut [A]
 - Washer [B]
 - Adjuster [C]
- Pull out the rear axle to the left and drop the rear wheel.

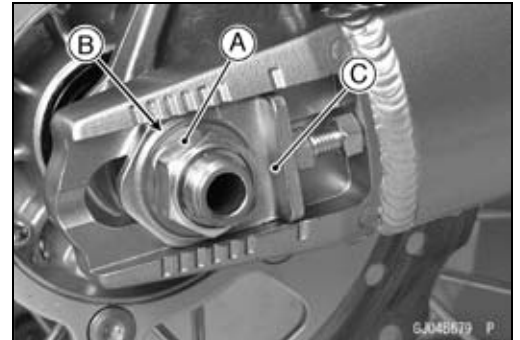

- Disengage the drive chain from the sprocket.
- Move the rear wheel back and remove it.
- Hang the drive chain [A] on the swingarm.

NOTICE

Do not lay the wheel on the ground with the disc facing down. This can damage or warp the disc. Place wooden blocks under the wheel so that the disc does not touch the ground.

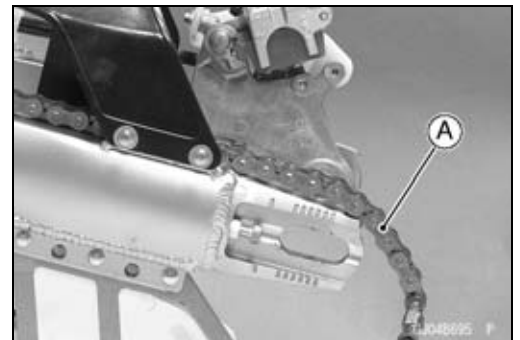

Rear Wheel Installation

- Fit the projection [A] on the cap to the groove [B] on the collar.
- The "R" letter [C] punched on the right side collar.

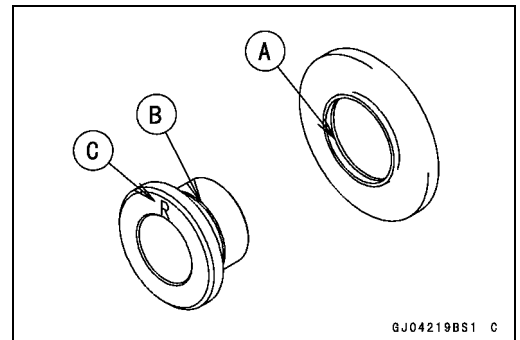

- Apply grease to the both side seal lips.
- Fit the caps and collars [A] on the both sides of the hub.

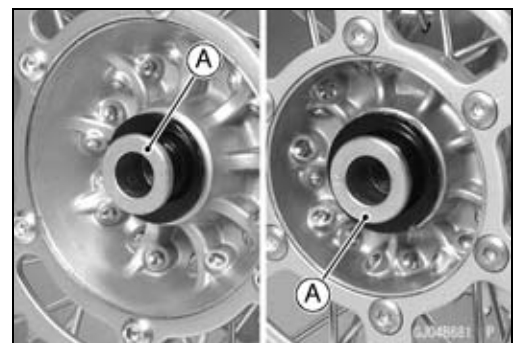

10-10 WHEELS/TIRES

Wheels (Rims)

- Install the caliper bracket [A] with the caliper installed onto the stopper rail [B] of the swingarm.
- Engage the drive chain with the rear sprocket.
- Insert the axle from the left side of the wheel.
- Replace the rear axle nut with a new one.
- Adjust the drive chain slack before tightening the axle nut (see Drive Chain Slack Inspection in the Periodic Maintenance chapter).
- Tighten:
Torque - Rear Axle Nut: 110 N·m (11.2 kgf·m, 81.1 ft·lb)
- Insert a new cotter pin [A].
- Bend the cotter pin as shown.

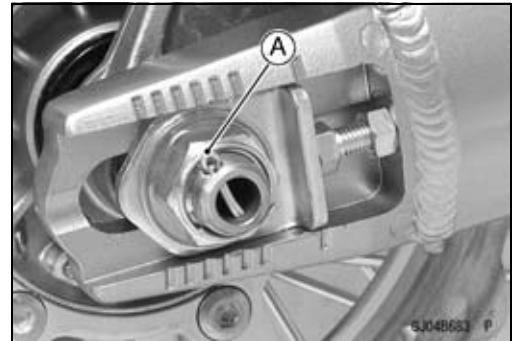
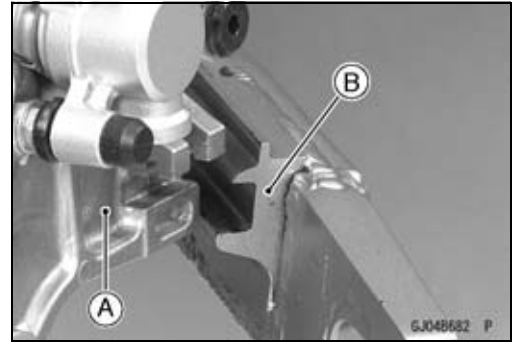

NOTE

- When inserting the cotter pin, if the slots in the nut do not align with the cotter pin hole in the axle shaft, tighten the nut clockwise [A] up to next alignment.
- It should be within 30 degree.
- Loosen one and tighten again when the slot goes past the nearest hole.

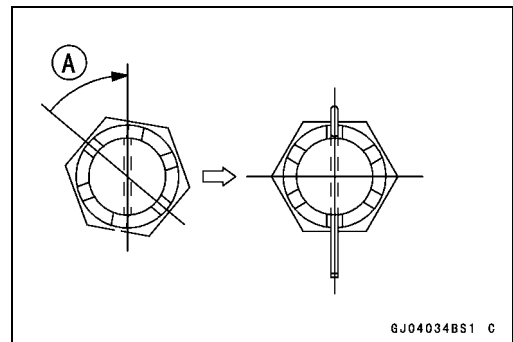

⚠ WARNING

A loose axle nut can lead to an accident resulting in serious injury or death. Tighten the axle nut to the proper torque and install a new cotter pin.

- Check the rear brake effectiveness (see Brake Operation Inspection in the Periodic Maintenance chapter).

⚠ WARNING

After servicing, it takes several applications of the brake pedal before the brake pads contact the disc, which could result in increased stopping distance and cause an accident resulting in injury or death. Do not attempt to ride the motorcycle until a firm brake pedal is obtained by pumping the pedal until the pads are against the disc.

Wheel Inspection

- Refer to the Wheel Bearing Damage Inspection in the Periodic Maintenance chapter.

Spoke Inspection

- Refer to the Spoke Tightness and Rim Runout Inspection in the Periodic Maintenance chapter.

Wheels (Rims)

Rim Inspection

- Refer to the Spoke Tightness and Rim Runout Inspection in the Periodic Maintenance chapter.

Axle Inspection

- Remove the axle (see Front/Rear Wheel Removal).
- Visually inspect the front and rear axle for damages.
- ★ If the axle is damaged or bent, replace it.
- Place the axle on the V blocks that are 100 mm (3.94 in.) [A] apart, and set a dial gauge [B] on the axle at a point halfway between the blocks. Turn [C] the axle to measure the runout. The difference between the highest and lowest dial gauge reading is the amount of runout.
- ★ If the axle runout exceeds the service limit, replace the axle.

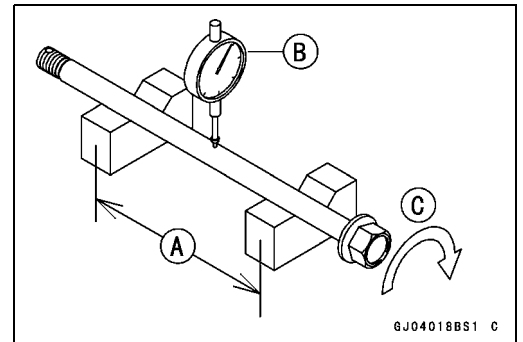

Axle Runout/100 mm (3.94 in.)

Standard: TIR 0.03 mm (0.001 in.) or less

Service Limit: TIR 0.2 mm (0.008 in.)

10-12 WHEELS/TIRES

Tires

Air Pressure Inspection/Adjustment

- Refer to the Air Pressure Inspection in the Periodic Maintenance chapter.

Tire Inspection

- Refer to the Wheel/Tire Damage Inspection in the Periodic Maintenance chapter.

Tire Removal

- Remove the wheel (see Front/Rear Wheel Removal).

NOTICE

Do not lay the front wheel on the ground with the disc facing down. This can damage or warp the disc. Place blocks under the wheel so that the disc does not touch the ground.

- To maintain wheel balance, mark the air valve position on the tire with chalk so that the tire can be reinstalled in the same position.

Chalk Mark or Yellow Mark [A]

Air Valve [B]

Align [C]

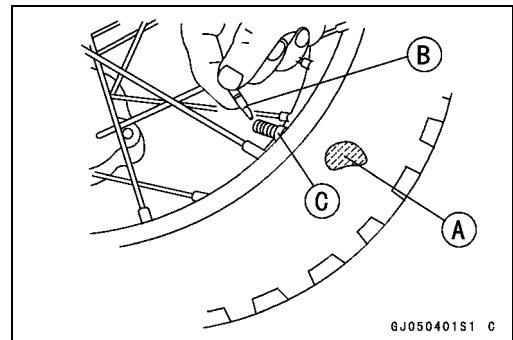

- Remove the air valve nut.
- Lubricate the tire beads and rim flanges on both sides with a soap and water solution or rubber lubricant. This helps the tire beads slip off the rim flanges.

NOTICE

Never lubricate with engine oil or petroleum distillates because they will deteriorate the tire.

- Break the beads away from both sides of the rim with the bead breaker [A].

Special Tool - Bead Breaker Assembly: 57001-1072

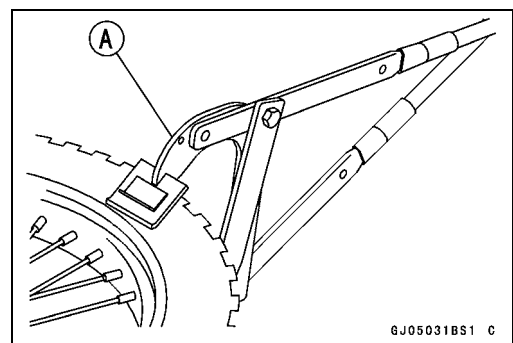

Tires

- Step on the side of the tire opposite air valve, and pry the tire off the rim with the tire iron [A] of the bead breaker protecting the rim with rim protectors [B].

Special Tools - Rim Protector: 57001-1063

Bead Breaker Assembly: 57001-1072

NOTICE

Take care not to insert the tire irons so deeply that the tube gets damaged.

- Remove the tube when one side of the tire is pried off.
- Pry the tire off the rim.
- Remove the rim protector.

Tire Installation

- Inspect the rim and the tire before installing the tire, and replace them if necessary.
- Apply a soap and water solution or rubber lubricant to both the tire bead and the rim flange.

KLX250V Model

- Check the tire rotation mark [A] on the front and rear tires and install them on the rim accordingly.

- Position the tire on the rim so that the air valve [A] is at the tire balance mark [B] (the chalk mark made during removal, or the paint mark on a new tire).
- Insert the valve stem into the rim, and screw the nut on loosely.
- Fit the rim protectors and use tire irons to install the tire bead.

NOTE

○ *To prevent rim damage, be sure to place the rim protectors at any place the tire irons are applied.*

- Replace the tire back on the rim from the opposite side of the valve.
- Insert the tire irons so deeply that the tube is not damaged.
- Similarly, slip the tire bead back over the rim on the other side.
- Check that the tube is not pinched between the tire and rim.

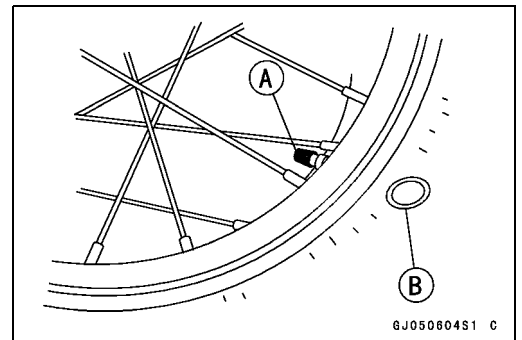
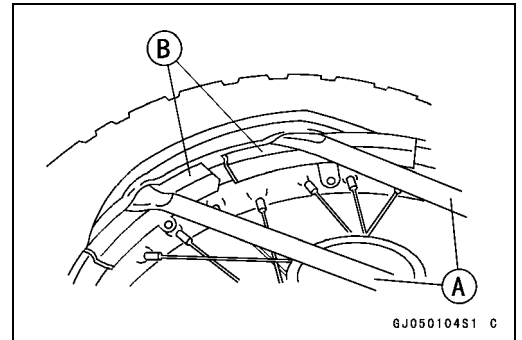

10-14 WHEELS/TIRES

Tires

- Tighten the valve stem nut [A], and put on the valve cap [B].
- Adjust the tire air pressure to the specified pressure (see Air Pressure Inspection in the Periodic Maintenance chapter).

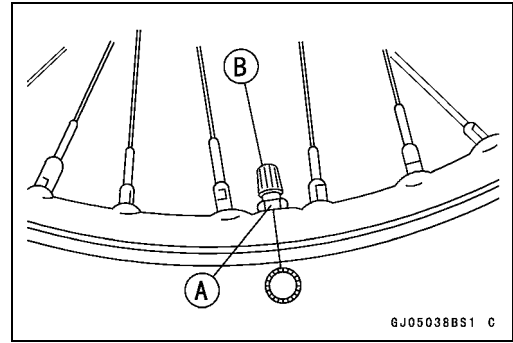

Hub Bearing

Hub Bearing Removal

- Remove the wheel (see Front/Rear Wheel Removal), and take out the following.

Front

- Grease Seal [A]
- Circlip [B]

Special Tool - Inside Circlip Pliers: 57001-143

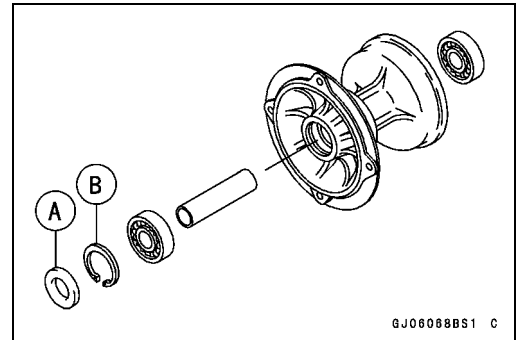

Rear

- Grease Seals [A]
- Circlip [B]

Special Tool - Inside Circlip Pliers: 57001-143

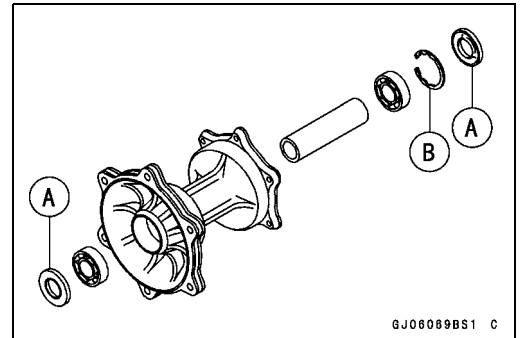

- Use the bearing remover to remove the hub bearings [A].

NOTICE

Do not lay the wheel on the ground with the disc facing down. This can damage or warp the disc. Place wooden blocks under the wheel so that the disc does not touch the ground.

- Special Tools - Bearing Remove Shaft, $\phi 13$: 57001-1377 [B]
- Bearing Remove Head, $\phi 15 \times \phi 17$: 57001-1267 [C]
- Bearing Remove Head, $\phi 20 \times \phi 22$: 57001-1293

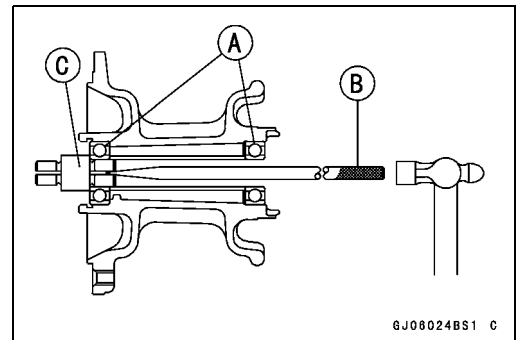

10-16 WHEELS/TIRES

Hub Bearing

Hub Bearing Installation

- Before installing the hub bearings, blow any dirt or foreign particles out of the hub with compressed air to prevent contamination of the bearings.
- Replace the bearings with new ones.
- Install the hub front bearings in the following sequence.
 - Press in the left side bearing [A] until it is bottomed.

Special Tool - Bearing Driver Set: 57001-1129

- Insert the collar [B] in the hub [C].
- Press in the right side bearing [D] until it is bottomed.

Special Tool - Bearing Driver Set: 57001-1129

- Install the rear hub bearings in the following sequence.
 - Press in the right side bearing until it is bottomed.

Special Tool - Bearing Driver Set: 57001-1129

- Insert the collar in the hub.
- Press in the left side bearing until it is bottomed.

Special Tool - Bearing Driver Set: 57001-1129

NOTE

- *Install the bearings so that the marked side or sealed side faces out.*

- Replace the circlips with a new one.

Special Tool - Inside Circlips Pliers: 57001-143

- Replace the grease seal with a new one.
- Press in the grease seal [A] so that the seal surface is flush [B] with the end of the hole.
- Apply grease to the grease seal lip.

Special Tool - Bearing Driver Set: 57001-1129 [C]

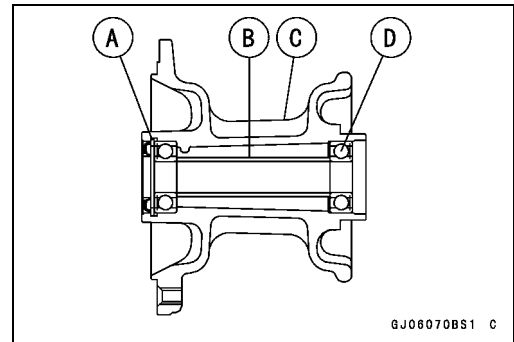

GJ08070BS1 C

Hub Bearing Inspection

Since the hub bearings are made to extremely close tolerances, the clearance can not normally be measured.

NOTE

- *Do not remove any bearings for inspection. If any bearings are removed, they will need to be replaced with new ones.*

- Turn each bearing in the hub back and forth [A] while checking for plays, roughness, or binding.
- ★ If bearing play, roughness, or binding is found, replace the bearing.
- Examine the bearing seal [B] for tears or leakage.
- ★ If the seal is torn or is leaking, replace the bearing.

Hub Bearing Lubrication

NOTE

- *Since the hub bearings are packed with grease and sealed, lubrication is not required.*

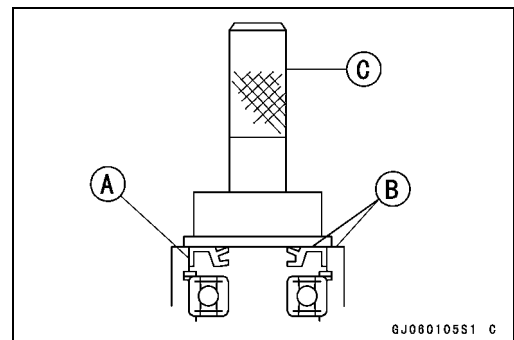

GJ080105S1 C

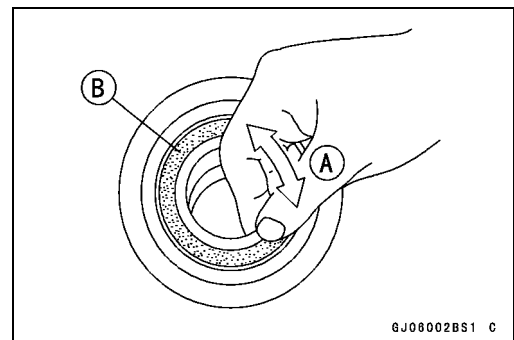

GJ08002BS1 C

Final Drive

Table of Contents

Exploded View	11-2
Specifications	11-4
Special Tool	11-5
Drive Chain	11-6
Drive Chain Slack Inspection	11-6
Drive Chain Slack Adjustment	11-6
Wheel Alignment Inspection/Adjustment	11-6
Drive Chain Wear Inspection	11-6
Drive Chain Lubrication.....	11-6
Drive Chain Guide Wear Inspection.....	11-6
Drive Chain Removal	11-6
Drive Chain Installation	11-6
Sprocket	11-7
Engine Sprocket Removal	11-7
Engine Sprocket Installation	11-7
Rear Sprocket Removal.....	11-8
Rear Sprocket Installation.....	11-8
Sprocket Wear Inspection.....	11-8
Rear Sprocket Warp Inspection	11-9

11-2 FINAL DRIVE

Exploded View

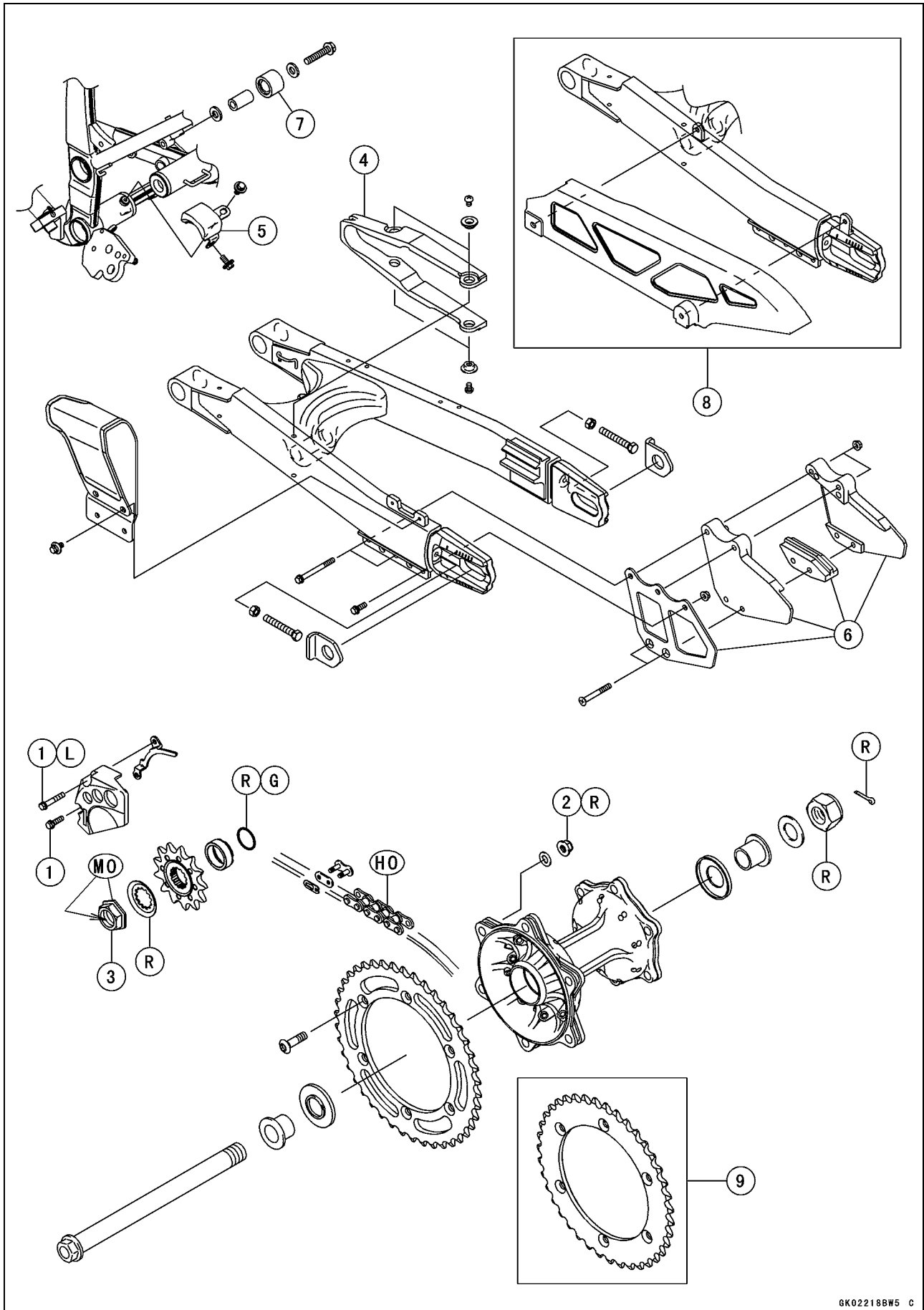

Exploded View

No.	Fastener	Torque			Remarks
		N·m	kgf·m	ft·lb	
1	Engine Sprocket Cover Bolts	9.8	1.0	87 in·lb	L (1)
2	Rear Sprocket Nuts	32	3.3	24	R
3	Engine Sprocket Nut	125	12.7	92.2	MO

- 4. Chain Slipper
- 5. Front Chain Guide
- 6. Rear Chain Guide
- 7. Chain Guide Roller
- 8. BR and EUR Models
- 9. KLX250V Model

G: Apply grease.

HO Apply heavy oil.

L: Apply a non-permanent locking agent.

MO: Apply molybdenum disulfide oil solution.

(mixture of engine oil and molybdenum disulfide grease in a weight ratio 10 : 1)

R: Replacement Parts

11-4 FINAL DRIVE

Specifications

Item	Standard	Service Limit
Drive Chain		
Chain Slack	35 ~ 45 mm (1.4 ~ 1.8 in.)	---
20-link Length	317.5 ~ 318.2 mm (12.50 ~ 12.53 in.)	323 mm (12.7 in.)
Standard Chain:		
Make	ENUMA	---
Type	EK520LV-O	---
Link:		
KLX250S	106 Links	---
KLX250V	104 Links	---
Sprockets		
Rear Sprocket Warp	0.4 mm (0.016 in.) or less	0.5 mm (0.02 in.)

Special Tool

Jack:
57001-1238

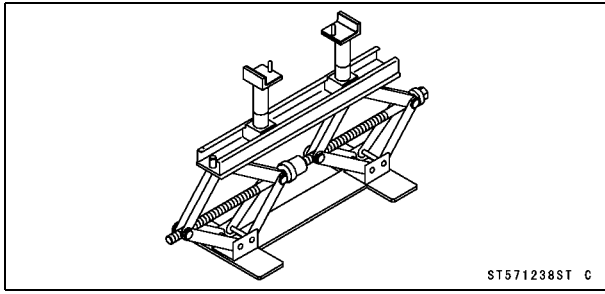

11-6 FINAL DRIVE

Drive Chain

Drive Chain Slack Inspection

- Refer to the Drive Chain Slack Inspection in the Periodic Maintenance chapter.

Drive Chain Slack Adjustment

- Refer to the Drive Chain Slack Adjustment in the Periodic Maintenance chapter.

Wheel Alignment Inspection/Adjustment

- Refer to the Wheel Alignment Inspection in the Periodic Maintenance chapter.

Drive Chain Wear Inspection

- Refer to the Drive Chain Wear Inspection in the Periodic Maintenance chapter.

Drive Chain Lubrication

- Refer to the Drive Chain Lubrication Condition Inspection in the Periodic Maintenance chapter.

Drive Chain Guide Wear Inspection

- Refer to the Drive Chain Guide Wear Inspection in the Periodic Maintenance chapter.

Drive Chain Removal

- Remove:
 - Engine Sprocket Cover (see Engine Sprocket Removal)
- Remove the clip [A] from the master link to separate the drive chain.
- Remove the drive chain from the chassis.

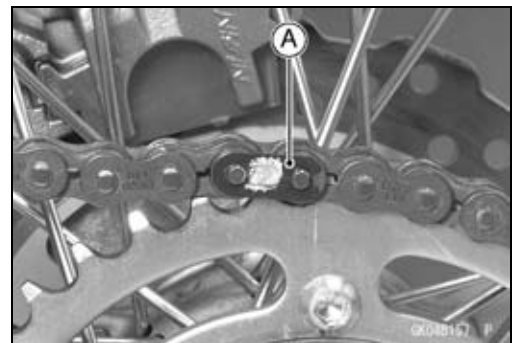

Drive Chain Installation

- Fit the drive chain back onto the sprockets with the ends at the rear sprocket.
- Install the master link [A] and O-rings [B] from the inside.
- Install the O-rings [C], then link plate [D] with the mark facing out.
- Install the clip [E].

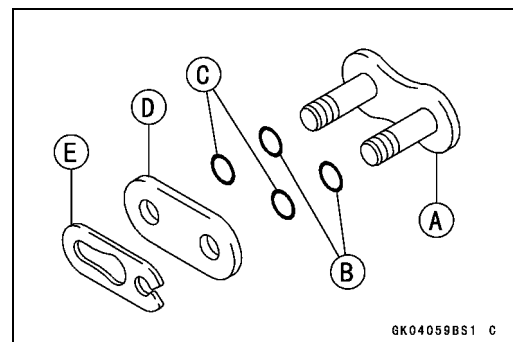

- Install the clip [A] so that the closed end of the "U" [B] pointed in the direction of chain rotation [C].
- Adjust the drive chain slack (see Drive Chain Slack Adjustment in the Periodic Maintenance chapter).

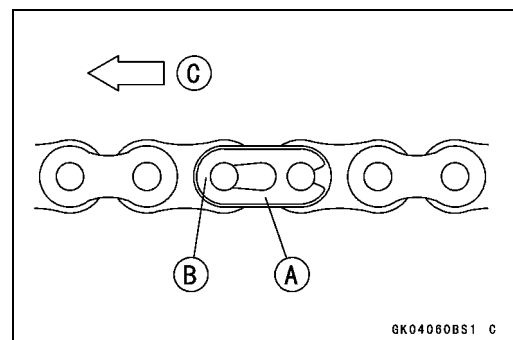

Sprocket

Engine Sprocket Removal

- Remove:
 - Engine Sprocket Cover Bolts [A]
 - Engine Sprocket Cover [B]
 - Chain Guide [C]

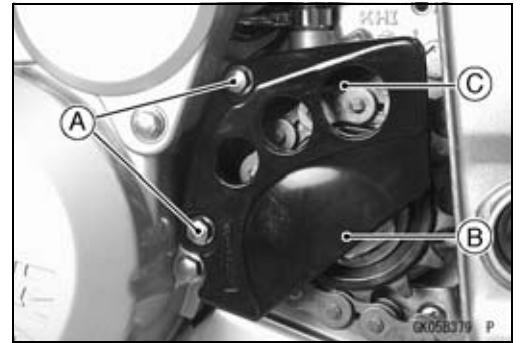

- Flatten out the bended washer [A].
- Remove:
 - Engine Sprocket Nut [B]
 - Washer

NOTE

○ When loosening the engine sprocket nut, hold the rear brake on.

- Slack off the drive chain fully.
- Remove the engine sprocket [C].

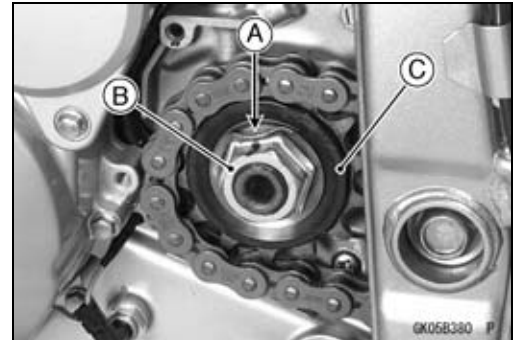

Engine Sprocket Installation

- Replace the sprocket washer with a new one.
- Install the engine sprocket so that stepped side [A] faces inside.
- Apply molybdenum disulfide oil solution to the threads of the output shaft and seating surface of the engine sprocket nut.
- Tighten:

Torque - Engine Sprocket Nut: 125 N·m (12.7 kgf·m, 92.2 ft·lb)

NOTE

○ Tighten the engine sprocket nut while applying the rear brake.

- After tightening the engine sprocket nut, bend [A] the one side of the washer over the nut.

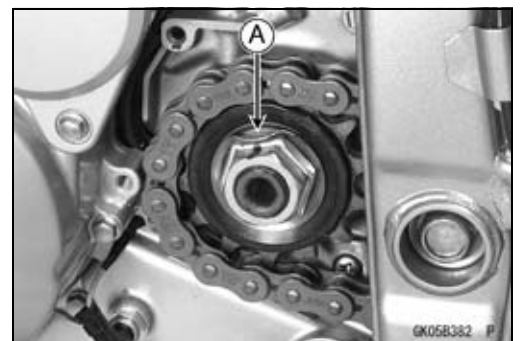
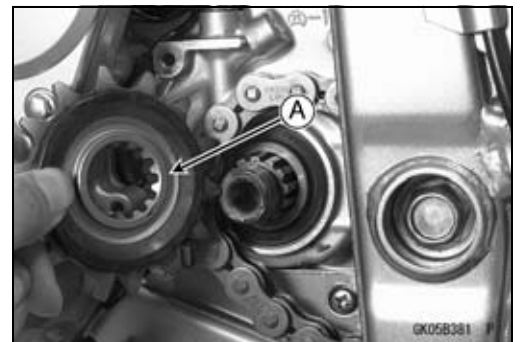

11-8 FINAL DRIVE

Sprocket

- Apply a non-permanent locking agent to the threads of the engine sprocket cover mounting bolt (upper) [A].
 - Install the chain guide [B] and engine sprocket cover [C].
- Torque - Engine Sprocket Cover Mounting Bolts: 9.8 N·m (1.0 kgf·m, 87 in·lb)**
- Adjust the drive chain slack (see Drive Chain Slack Adjustment in the Periodic Maintenance chapter).

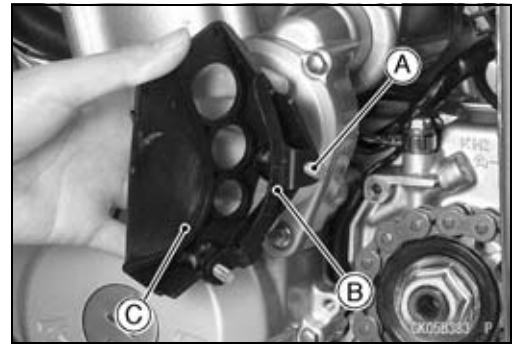

Rear Sprocket Removal

- Remove the rear wheel (see Rear Wheel Removal in the Wheels/Tires chapter).

NOTICE

Do not lay the wheel on the ground with the disc facing down. This can damage or warp the disc. Place wooden blocks under the wheel so that the disc does not touch the ground.

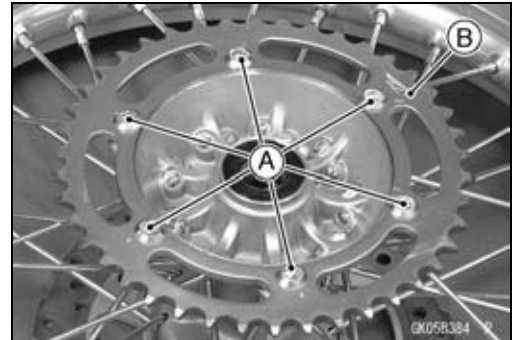

- Remove:
 - Rear Sprocket Bolts [A] and Nuts
 - Rear Sprocket [B]

Rear Sprocket Installation

- Install the sprocket facing the tooth number marking [A] outward.
- Replace the rear sprocket nuts with new ones.
- Tighten:
 - **Torque - Rear Sprocket Nuts: 32 N·m (3.3 kgf·m, 24 ft·lb)**
- Install the rear wheel (see Rear Wheel Installation in the Wheels/Tires chapter).



Sprocket Wear Inspection

- Visually inspect the engine and rear sprocket teeth for wear and damage.
- ★ If the teeth are worn as illustrated, replace the sprocket, and inspect the drive chain wear (see Drive Chain Wear Inspection in the Periodic Maintenance chapter).
 - Worn Tooth (Engine Sprocket) [A]
 - Worn Tooth (Rear Sprocket) [B]
 - Direction of Rotation [C]

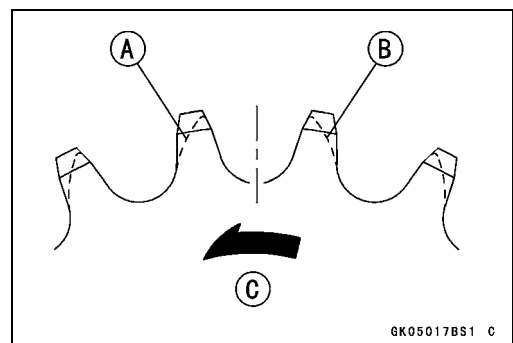

NOTE

- If a sprocket requires replacement, the chain is probably worn also. When replacing a sprocket, inspect the chain.

Sprocket

Rear Sprocket Warp Inspection

- Raise the rear wheel off the ground with jack so that it will turn freely.

Special Tool - Jack: 57001-1238

- Set a dial gauge [A] against the rear sprocket [B] near the teeth as shown, and rotate [C] the rear wheel to measure the sprocket runout (warp). The difference between the highest and lowest dial gauge readings is the amount of runout (warp).

Rear Sprocket Warp

Standard: 0.4 mm (0.016 in.) or less

Service Limit: 0.5 mm (0.02 in.)

- ★ If the runout exceeds the service limit, replace the rear sprocket.

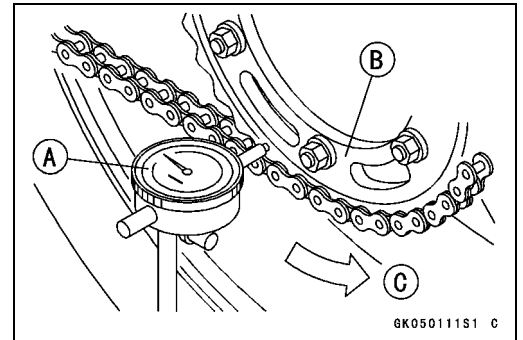

Brakes

Table of Contents

Exploded View	12-2
Specifications	12-6
Special Tool	12-7
Brake Pedal	12-8
Brake Pedal Position Inspection	12-8
Brake Pedal Position Adjustment.....	12-8
Brake Pedal Removal	12-8
Brake Pedal Installation	12-9
Calipers	12-10
Front Caliper Removal	12-10
Rear Caliper Removal.....	12-10
Caliper Installation	12-11
Front Caliper Disassembly.....	12-11
Front Caliper Assembly.....	12-11
Rear Caliper Disassembly	12-11
Rear Caliper Assembly	12-11
Caliper Fluid Seal Damage	12-12
Caliper Dust Boot and Friction Boot Damage.....	12-12
Caliper Piston and Cylinder Damage.....	12-13
Caliper Holder Shaft Wear	12-13
Brake Pads	12-14
Front Brake Pad Removal.....	12-14
Front Brake Pad Installation.....	12-14
Rear Brake Pad Removal	12-14
Rear Brake Pad Installation	12-15
Brake Pad Wear Inspection	12-15
Master Cylinder	12-16
Front Master Cylinder Removal	12-16
Front Master Cylinder Installation	12-16
Rear Master Cylinder Removal.....	12-17
Rear Master Cylinder Installation.....	12-17
Front Master Cylinder Disassembly	12-17
Rear Master Cylinder Disassembly.....	12-18
Master Cylinder Assembly	12-18
Master Cylinder Inspection	12-18
Brake Disc	12-19
Brake Disc Removal	12-19
Brake Disc Installation	12-19
Brake Disc Wear	12-19
Brake Disc Warp	12-20
Brake Fluid	12-21
Brake Fluid Level Inspection.....	12-21
Brake Fluid Change	12-21
Brake Line Bleeding.....	12-21
Brake Hose.....	12-24
Brake Hose Removal/Installation.....	12-24
Brake Hose Inspection.....	12-24

12-2 BRAKES

Exploded View

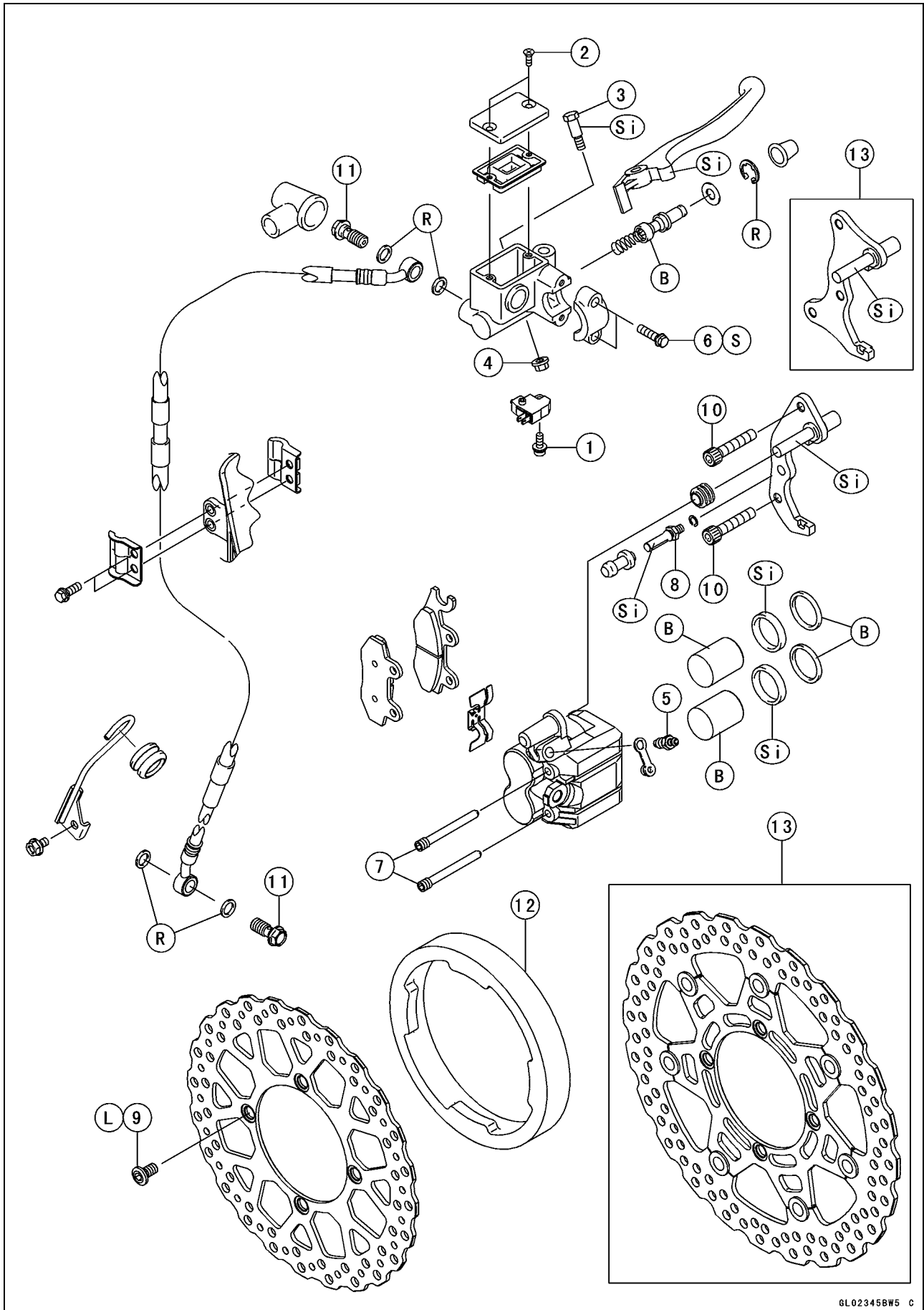

Exploded View

No.	Fastener	Torque			Remarks
		N·m	kgf·m	ft·lb	
1	Front Brake Light Switch Mounting Screw	1.2	0.12	11 in·lb	
2	Front Master Cylinder Reservoir Cap Screws	1.5	0.15	13 in·lb	
3	Brake Lever Pivot Bolt	5.9	0.60	52 in·lb	Si
4	Brake Lever Pivot Bolt Locknut	5.9	0.60	52 in·lb	
5	Caliper Bleed Valve	7.8	0.80	69 in·lb	
6	Front Master Cylinder Clamp Bolts	8.8	0.90	78 in·lb	S
7	Front Caliper Brake Pad Pins	17	1.7	12	
8	Front Caliper Holder Shaft	17	1.7	12	Si
9	Front Brake Disc Mounting Bolts	23	2.3	17	L
10	Front Caliper Mounting Bolts	25	2.5	18	
11	Brake Hose Banjo Bolts	25	2.5	18	

12. KLX250S Model

13. KLX250V Model

B: Apply brake fluid.

L: Apply a non-permanent locking agent.

R: Replacement Parts

S: Follow the specified tightening sequence.

Si: Apply silicone grease (ex. PBC grease).

12-4 BRAKES

Exploded View

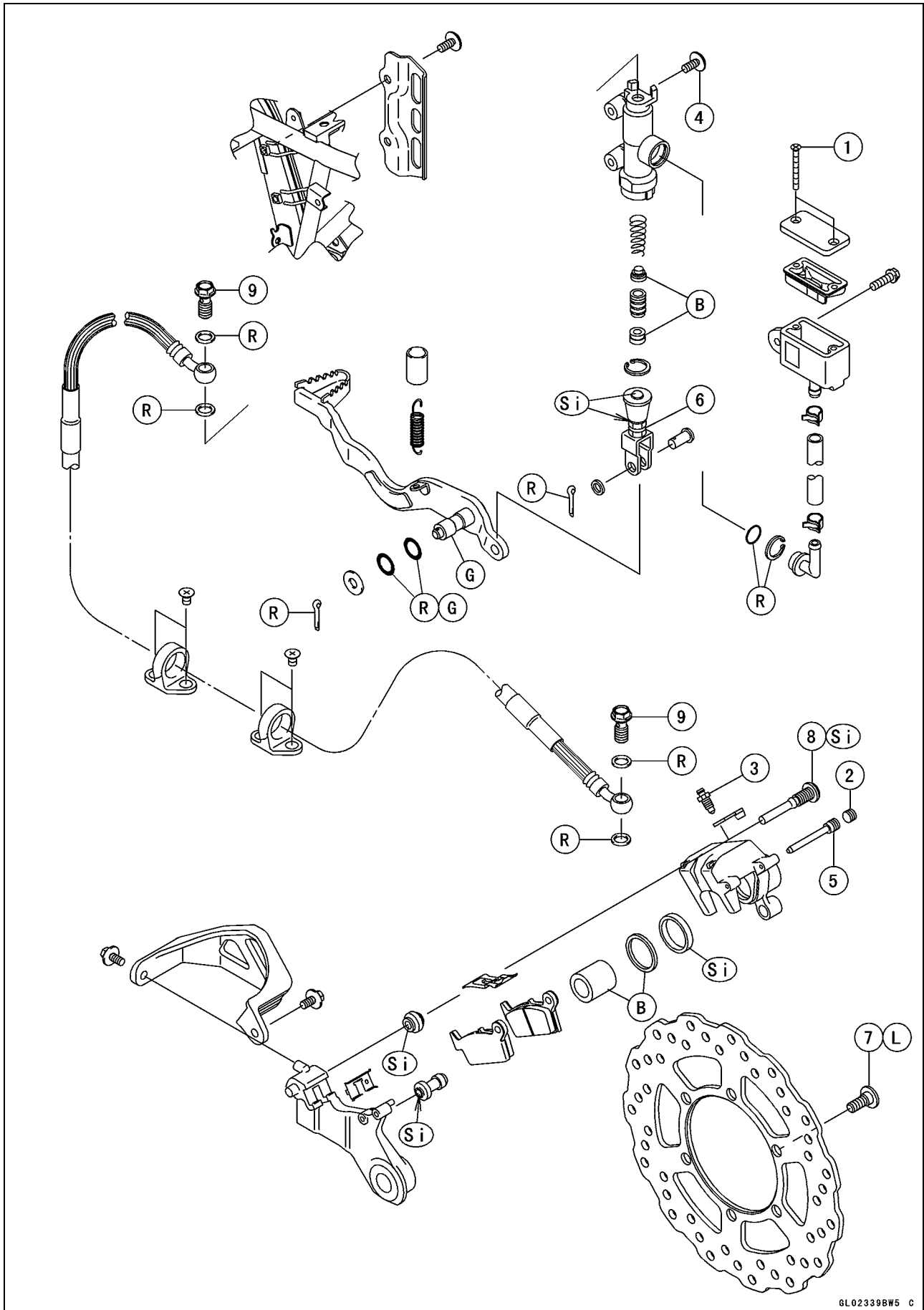

Exploded View

No.	Fastener	Torque			Remarks
		N·m	kgf·m	ft·lb	
1	Rear Master Cylinder Reservoir Cap Screws	1.5	0.15	13 in·lb	
2	Brake Pad Pin Cap	2.5	0.25	22 in·lb	
3	Caliper Bleed Valve	7.8	0.80	69 in·lb	
4	Rear Master Cylinder Mounting Screws	7.8	0.80	69 in·lb	
5	Rear Caliper Brake Pad Pin	17	1.7	12	
6	Rear Master Cylinder Push Rod Locknut	17	1.7	12	
7	Rear Brake Disc Mounting Bolts	23	2.3	17	L
8	Rear Caliper Mounting Bolt	27	2.8	20	Si
9	Brake Hose Banjo Bolts	25	2.5	18	

B: Apply brake fluid.

G: Apply grease.

L: Apply a non-permanent locking agent.

R: Replacement Parts

Si: Apply silicone grease (ex. PBC grease).

12-6 BRAKES

Specifications

Fastener	Standard	Service Limit
Brake Lever, Brake Pedal		
Brake Lever Free Play	Non-adjustable	— — —
Pedal Free Play	Non-adjustable	— — —
Pedal Position:		
KLX250S	About 0.7 mm (0.03 in.) above top of footpeg	— — —
KLX250V	About 13.4 mm (0.53 in.) below top of footpeg	— — —
Brake fluid		
Grade	DOT3 or DOT4	— — —
Brake Pads		
Pad Lining Thickness:		
Front	4.5 mm (0.18 in.)	1 mm (0.04 in.)
Rear	6.4 mm (0.25 in.)	1 mm (0.04 in.)
Brake Disc		
Thickness:		
Front:		
KLX250S	3.35 ~ 3.65 mm (0.132 ~ 0.144 in.)	2.8 mm (0.11 in.)
KLX250V	3.8 ~ 4.2 mm (0.15 ~ 0.17 in.)	3.5 mm (0.14 in.)
Rear	4.30 ~ 4.70 mm (0.169 ~ 0.185 in.)	3.8 mm (0.15 in.)
Runout	TIR 0.12 mm (0.0047 in.) or less	TIR 0.3 mm (0.01 in.)

Special Tool

Jack:
57001-1238

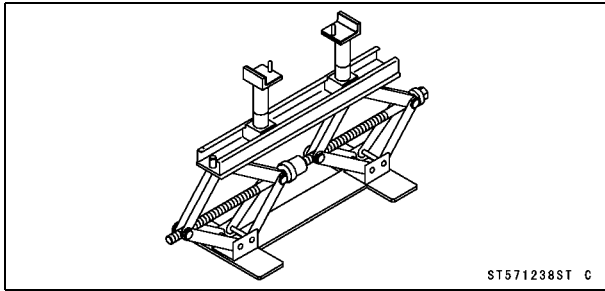

12-8 BRAKES

Brake Pedal

Brake Pedal Position Inspection

- Check that the brake pedal [A] is in the correct position.
Footpeg [B]

Pedal Position

Standard:

KLX250S [C] About 0.7 mm (0.03 in.) [D] above
top of footpeg

KLX250V [E] About 13.4 mm (0.53 in.) [F]
below top of footpeg

- ★ If it is incorrect, adjust the brake pedal position.

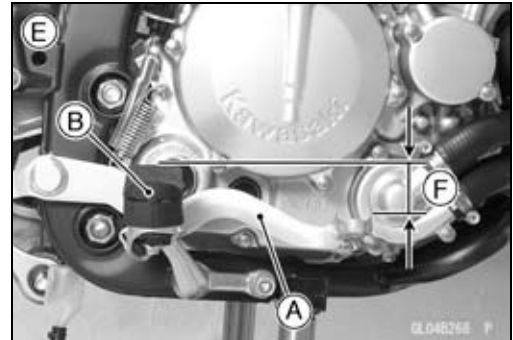
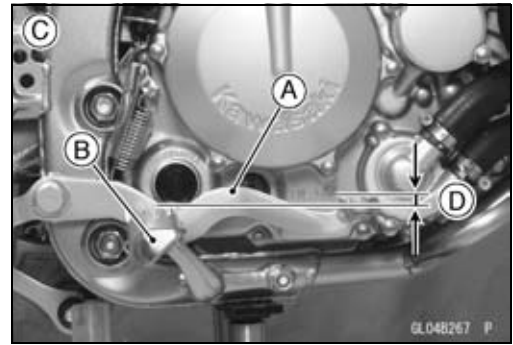

Brake Pedal Position Adjustment

NOTE

○ Usually it is not necessary to adjust the pedal position, but always adjust it when the push rod locknut has been loosened.

- Loosen the locknut [A] and turn the push rod with the hex head [B] to achieve the correct pedal position.
- ★ If the length [C] shown is 75 ± 1 mm (3.0 ± 0.04 in.), the pedal position will be within the standard range.
- Tighten:

**Torque - Rear Master Cylinder Push Rod Locknut: 17 N·m
(1.7 kgf·m, 12 ft·lb)**

- Check the brake light switch operation (see Brake Light Switch Operation Inspection in the Periodic Maintenance chapter).

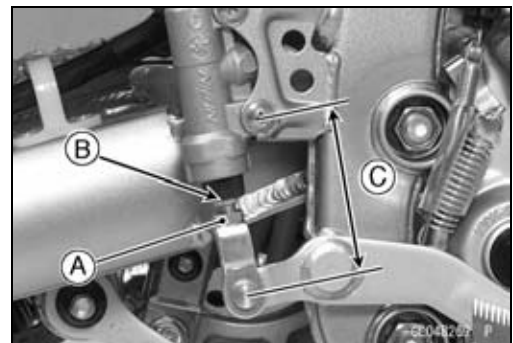

Brake Pedal Removal

- Remove:
Cotter Pins [A]
Joint Pin [B]
Washers [C]

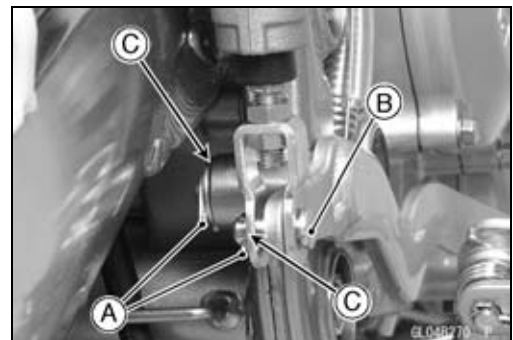

Brake Pedal

- Remove:
 - Brake Pedal Return Spring [A]
 - Brake Light Switch Spring [B]
 - Brake Pedal [C]

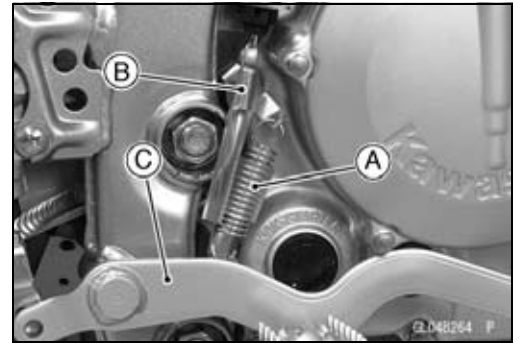

Brake Pedal Installation

- Replace O-rings [A] with new ones, and apply grease to the O-rings.
- Apply grease to the shaft portion of the brake pedal.
- Install the brake pedal onto the frame with the return spring and brake light switch spring.
- Replace the cotter pins of the brake pedal pivot and rear master cylinder joint pin with new ones.
- Insert washer and cotter pin into the shaft portion of the brake pedal, and bend cotter pin end.
- Insert a cotter pin into the joint pin, and bend its ends.
- Adjust the brake pedal position (see Brake Pedal Position Adjustment).
- Check the brake light switch operation (see Brake Light Switch Operation Inspection in the Periodic Maintenance chapter).

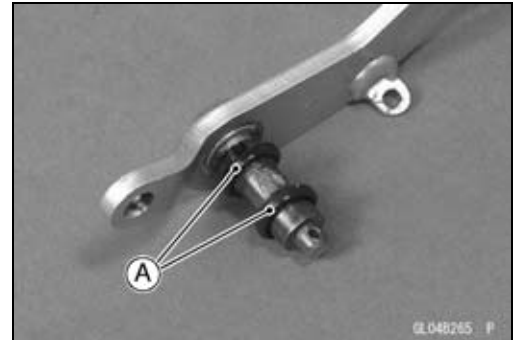

12-10 BRAKES

Calipers

Front Caliper Removal

- Loosen the banjo bolt [A] at the brake hose lower end, and tighten it loosely.
- Unscrew the brake hose clamp bolt [B].
- Unscrew the caliper mounting bolts [C], and detach the caliper [D] from the disc.
- Unscrew the banjo bolt and remove the brake hose [E] from the caliper (see Brake Hose and Pipe Replacement in the Periodic Maintenance chapter).

NOTICE

Immediately wash away any brake fluid that spills.

NOTE

○If the caliper is to be disassembled after removal and if compressed air is not available, disassemble the caliper before the brake hose is removed (see Caliper Rubber Parts Replacement in the Periodic Maintenance chapter).

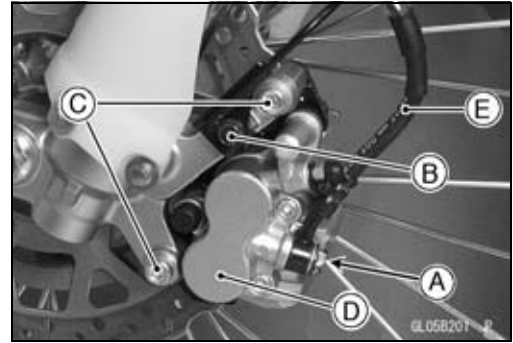

Rear Caliper Removal

- Remove:
 - Rear Caliper Guard Bolts [A]
 - Rear Caliper Guard [B]
 - Rear Wheel (see Rear Wheel Removal in the Wheels/Tires chapter)
- Loosen the banjo bolt [C] at the brake hose lower end, and tighten it loosely.
- Unscrew the banjo bolt [A] and remove the brake hose [B] from the caliper.
- Remove the rear caliper [C] together with the caliper bracket [D].

NOTICE

Immediately wash away any brake fluid that spills.

NOTE

○If the caliper is to be disassembled after removal and if compressed air is not available, disassemble the caliper before the brake hose is removed (see Caliper Rubber Parts Replacement in the Periodic Maintenance chapter).

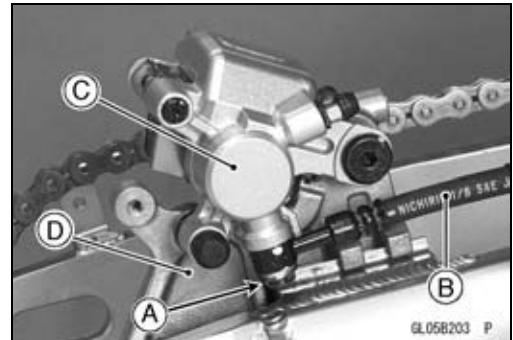
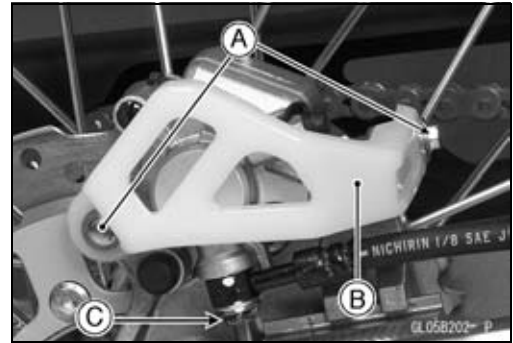

Calipers

- Remove the caliper mounting bolt [A] to separate the caliper [B] and caliper bracket [C].

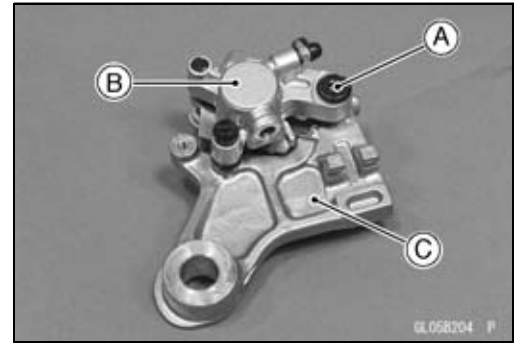

Caliper Installation

- Install the caliper and brake hose lower end.
- Replace the washers on each side of hose fitting with new ones.
- Apply silicone grease to the rear caliper mounting bolt.
- Tighten:

Torque - Caliper Mounting Bolts

Front: 25 N·m (2.5 kgf·m, 18 ft·lb)

Rear: 27 N·m (2.8 kgf·m, 20 ft·lb)

Brake Hose Banjo Bolt: 25 N·m (2.5 kgf·m, 18 ft·lb)

- Install the removed parts.
- Bleed the brake line (see Brake Line Bleeding).
- Check the brake for good braking power, no brake drag, and no fluid leakage.

⚠ WARNING

After servicing, it takes several applications of the brake lever or pedal before the brake pads contact the disc, which could result in increased stopping distance and cause an accident resulting in injury or death. Do not attempt to ride the motorcycle until a firm brake lever or pedal is obtained by pumping the lever or pedal until the pads are against the disc.

Front Caliper Disassembly

- Refer to the Caliper Rubber Parts Replacement in the Periodic Maintenance chapter.

Front Caliper Assembly

- Refer to the Caliper Rubber Parts Replacement in the Periodic Maintenance chapter.

Rear Caliper Disassembly

- Refer to the Caliper Rubber Parts Replacement in the Periodic Maintenance chapter.

Rear Caliper Assembly

- Refer to the Caliper Rubber Parts Replacement in the Periodic Maintenance chapter.

12-12 BRAKES

Calipers

Caliper Fluid Seal Damage

The fluid seal (piston seal) [A] is placed around the piston to maintain clearance between the pad and the disc. If the seal is in a poor condition, it could lead the pad to wear excessively or the brake to drag, which may cause the temperature of the discs or the brake fluid to increase.

- Replace the fluid seal if it exhibits any of the conditions listed below.

- Brake fluid leakage around the pad.
- Brakes overheat.
- Considerable difference in inner and outer pad wear.
- Seal and piston are stuck together.

- ★ If the fluid seal is replaced, replace the dust seal [B] as well. Also, replace all seals every other time the pads are changed.

Front Caliper [C]

Rear Caliper [D]

Caliper Dust Boot and Friction Boot Damage

- Check that the dust boot [A] and friction boot [B] are not cracked, worn, swollen, or otherwise damaged.

- ★ If they show any damage, replace it.

Front Caliper [C]

Rear Caliper [D]

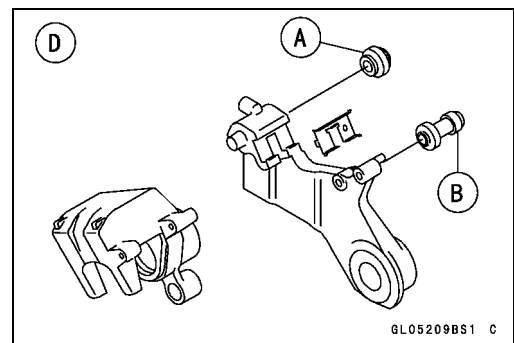
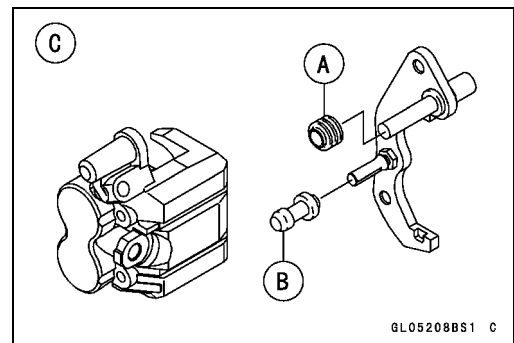
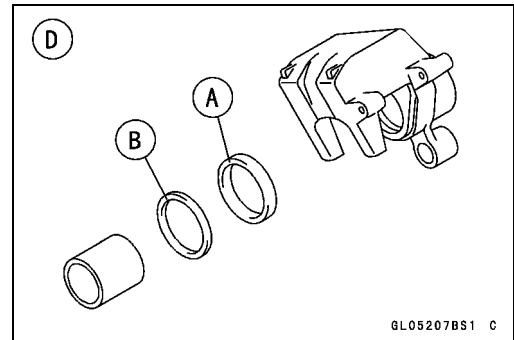
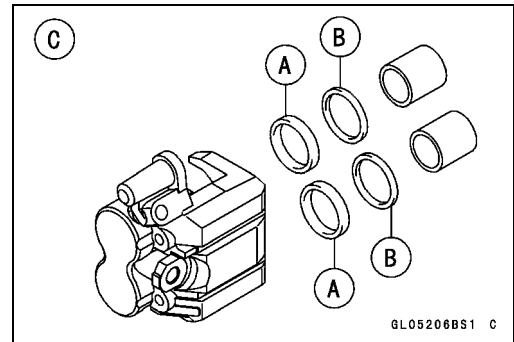

Calipers

Caliper Piston and Cylinder Damage

- Visually inspect the pistons [A] and cylinder surfaces.
- ★ Replace the caliper if the cylinder and piston are badly scores or rusty.
 - Front Caliper [B]
 - Rear Caliper [C]

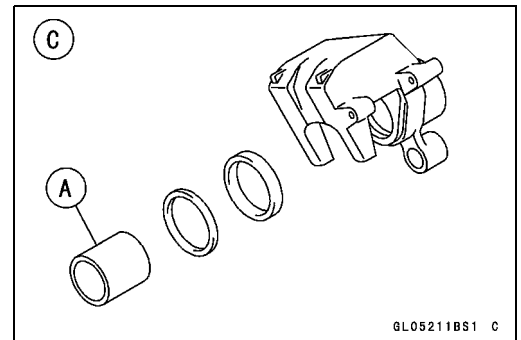
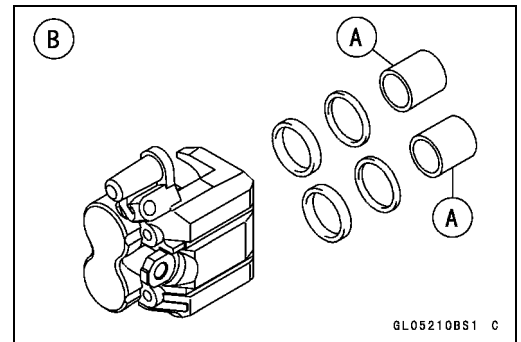

Caliper Holder Shaft Wear

The caliper body must slide smoothly on the caliper holder shafts [A]. If the body does not slide smoothly, one pad will wear more than the other, pad wear will increase, and constant drag on the disc will raise brake and brake fluid temperature.

- Check to see that the caliper holder shafts are not badly worn or stepped, and that the rubber friction boots are not damaged.
- ★ If the rubber friction boot is damaged, replace the rubber friction boot. To replace the friction boot, remove the pads and the caliper bracket.
- ★ If the caliper holder shaft is damaged, replace the caliper bracket or holder shaft (front caliper).

Torque - Front Caliper Holder Shaft: 17 N·m (1.7 kgf·m, 12 ft·lb)

- Front Caliper [B]
- Rear Caliper [C]

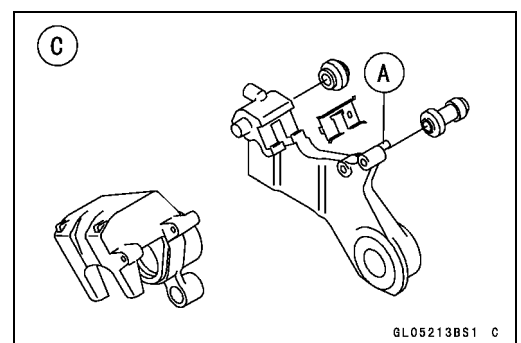
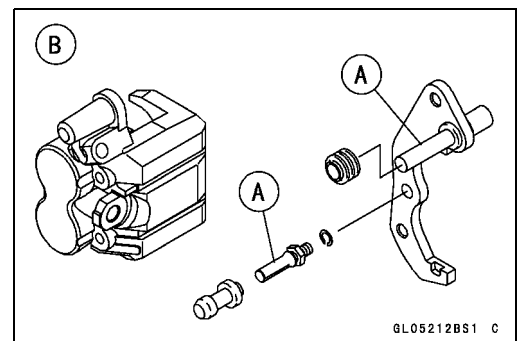

12-14 BRAKES

Brake Pads

Front Brake Pad Removal

- Loosen the pad pins [A].
- Remove the front caliper with the brake hose installed (see Front Caliper Removal).
- Remove the pad pins.
- Remove the pad [A] of the jaw side.
- Remove the pad [B] of the piston side.

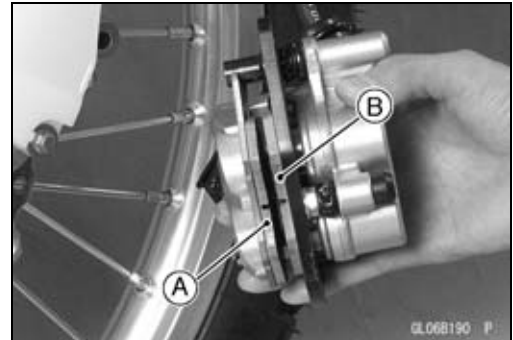
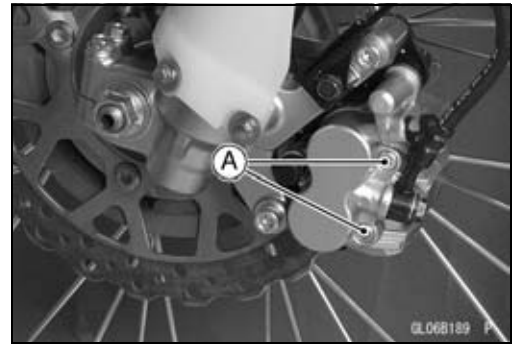

Front Brake Pad Installation

- Push the caliper pistons in by hand as far as they will go.
- Install the anti-rattle spring in its correct position.
- Install the pad on the piston side first, then install the other pad.
- Tighten the brake pad pins temporary.
- Install the front brake caliper (see Front Brake Caliper Installation).
- Tighten:

Torque - Front Caliper Brake Pad Pins: 17 N·m (1.7 kgf·m, 12 ft·lb)

⚠ WARNING

After servicing, it takes several applications of the brake lever before the brake pads contact the disc, which could result in increased stopping distance and cause an accident resulting in injury or death. Do not attempt to ride the motorcycle until a firm brake lever is obtained by pumping the lever until the pads are against the disc.

Rear Brake Pad Removal

- Remove:
 - Rear Caliper Guard Bolts [A]
 - Rear Caliper Guard [B]

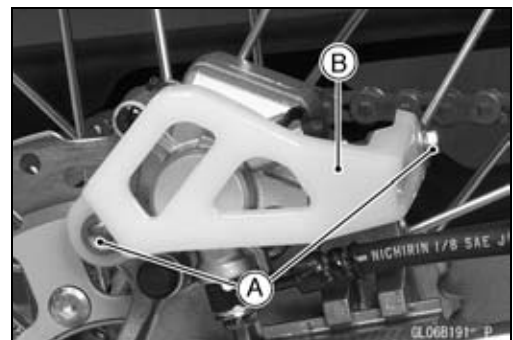

Brake Pads

- Remove:
 - Plug [A]
 - Pad Pin [B]
 - Piston Side Pad [C]
 - Jaw Side Pad [D]

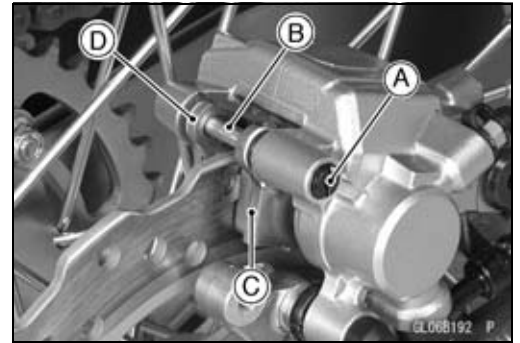

Rear Brake Pad Installation

- Push the caliper piston in by hand as far as it will go.
- Install the anti-rattle spring in its correct position.
- Install the pad on the piston side first, then install the other pad.
- Tighten the brake pad pins temporary.
- Install the rear brake caliper (see Rear Brake Caliper Installation).
- Tighten:
 - Torque - Rear Caliper Brake Pad Pin: 17 N·m (1.7 kgf·m, 12 ft·lb)

⚠ WARNING

After servicing, it takes several applications of the brake pedal before the brake pads contact the disc, which could result in increased stopping distance and cause an accident resulting in injury or death. Do not attempt to ride the motorcycle until a firm brake pedal is obtained by pumping the pedal until the pads are against the disc.

Brake Pad Wear Inspection

- Refer to the Brake Pad Wear Inspection in the Periodic Maintenance chapter.

12-16 BRAKES

Master Cylinder

Front Master Cylinder Removal

- Disconnect the brake hose from the master cylinder (see Brake Hose Replacement in the Periodic Maintenance chapter).
- Disconnect the front brake light switch connectors [A].

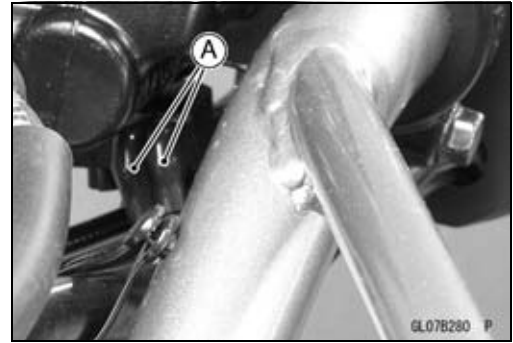

- Unscrew the clamp bolts [A], and take off the master cylinder as an assembly with the reservoir, brake lever and brake switch installed.

NOTICE

Immediately wash away any brake fluid that spills.

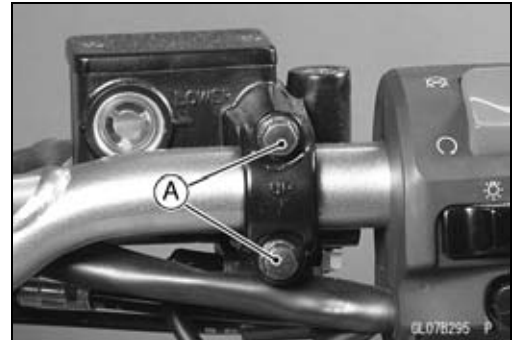

Front Master Cylinder Installation

- Install the front master cylinder so that the punch mark [A] of the handlebar is aligned with the mating surface [B] of the master cylinder clamp to level the reservoir.

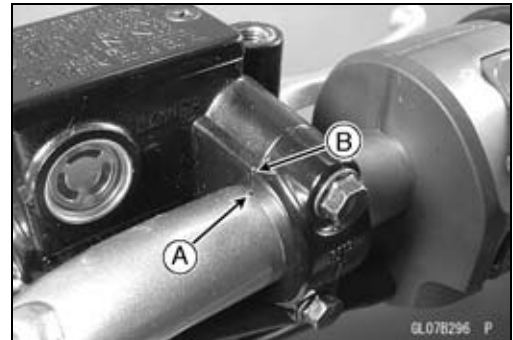

- The master cylinder clamp must be installed with the arrow mark [A] upward.
- Tighten the upper clamp bolt [B] first, and then the lower clamp bolt [C].
- There will be a gap at the lower part of the clamp after tightening.

Torque - Front Master Cylinder Clamp Bolts: 8.8 N·m (0.90 kgf·m, 78 in·lb)

- Replace the washers on each side of the hose fitting with new ones.
- Tighten:

Torque - Brake Hose Banjo Bolt: 25 N·m (2.5 kgf·m, 18 ft·lb)

- Bleed the brake line (see Brake Line Bleeding).
- Check the brake for good braking power, no brake drag, and no fluid leakage.

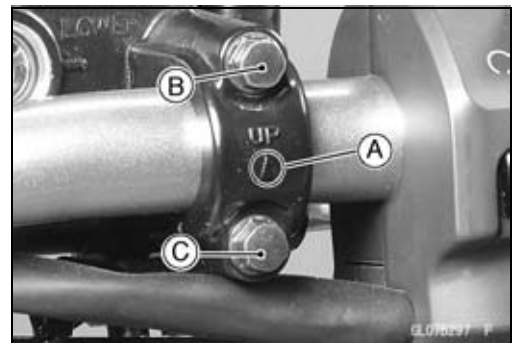

Master Cylinder

Rear Master Cylinder Removal

- Remove:
 - Cotter Pin [A]
 - Joint Pin [B]
 - Washer [C]
- Unscrew the brake hose banjo bolt [A] on the master cylinder (see Brake Hose and Pipe Replacement in the Periodic Maintenance chapter).
- Remove:
 - Rear Master Cylinder Mounting Screws [B]
 - Rear Master Cylinder [C]
- Slide the reservoir hose lower end clamp [A].
- Pull off the reservoir hose lower end, and drain the brake fluid into a container.

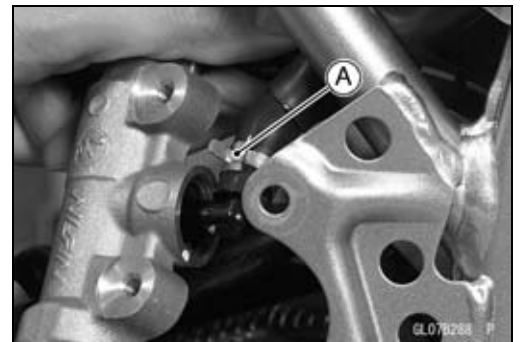
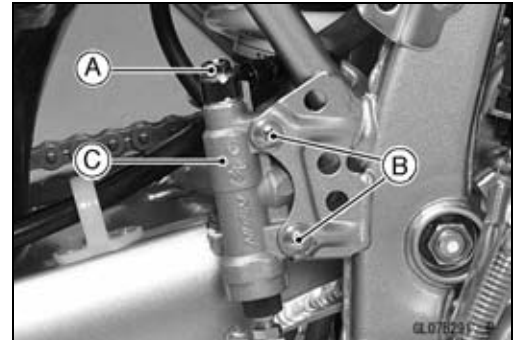
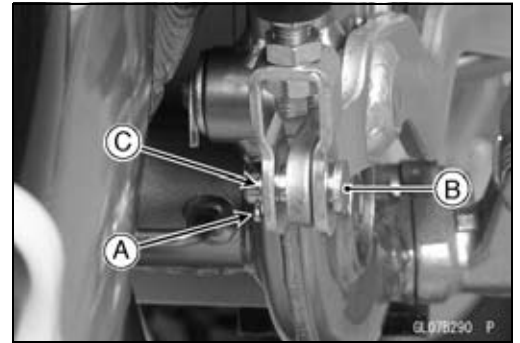

Rear Master Cylinder Installation

- Replace the washers on each side of hose fitting with new ones.
- Tighten:
 - **Torque - Rear Master Cylinder Mounting Screws: 7.8 N·m (0.80 kgf·m, 69 in·lb)**
 - **Brake Hose Banjo Bolts: 25 N·m (2.5 kgf·m, 18 ft·lb)**
- Replace the cotter pin [A] with a new one.
- Install the joint pin [B] and washer [C].
- Insert the cotter pin and bend the pin ends.
- Bleed the brake line (see Brake Line Bleeding).
- Check the brake for good braking power, no brake drag, and no fluid leakage.

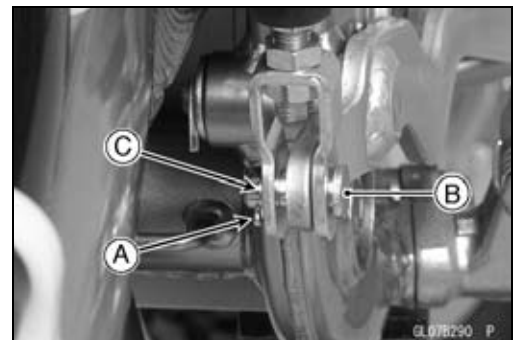

Front Master Cylinder Disassembly

- Refer to the Master Cylinder Rubber Parts Replacement in the Periodic Maintenance chapter.

12-18 BRAKES

Master Cylinder

Rear Master Cylinder Disassembly

- Refer to the Master Cylinder Rubber Parts Replacement in the Periodic Maintenance chapter.

Master Cylinder Assembly

- Refer to the Master Cylinder Rubber Parts Replacement in the Periodic Maintenance chapter.

Master Cylinder Inspection

- Remove the master cylinders (see Front/Rear Master Cylinder Removal).
- Disassemble the front and rear master cylinders.
- Check that there are no scratches, rust or pitting on the inner wall [A] of each master cylinder and on the outside of each piston [B].
- ★ If a master cylinder or piston shows any damage, replace them.
- Inspect the primary cup [C] and secondary cup [D].
- ★ If a cup is worn, damaged softened (rotted), or swollen, the piston assembly should be replaced to renew the cups.
- ★ If fluid leakage is noted at the brake lever, the piston assembly should be replaced to renew the cups.
- Check the dust covers [E] for damage.
- ★ If they are damaged, replace them.
- Check the piston return springs [F] for any damage.
- ★ If the springs are damaged, replace them.
- Check that relief port [G] and supply port [H] are not plugged.
- ★ If the relief port becomes plugged, the brake pads will drag on the disc. Blow the ports clean with compressed air.

Front Master Cylinder [I]

Rear Master Cylinder [J]

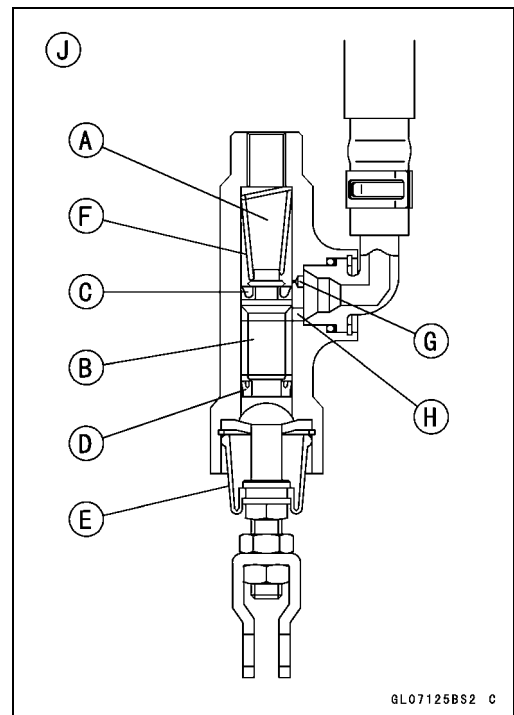
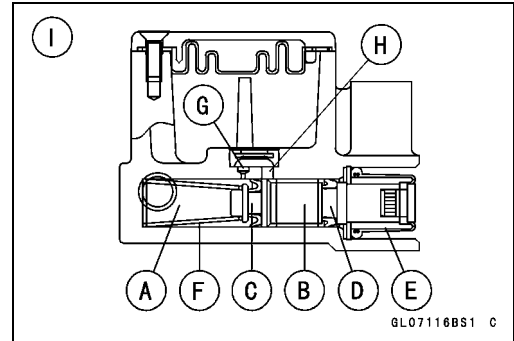

Brake Disc

Brake Disc Removal

- Remove the wheel (see Front/Rear Wheel Removal in the Wheels/Tires chapter).
- Unscrew the mounting bolts [A], and take off the disc [B].



Brake Disc Installation

KLX250S Model

- Before front brake disc installation, install the damper [A] to the hub so that the projections [B] contact the hub flange.

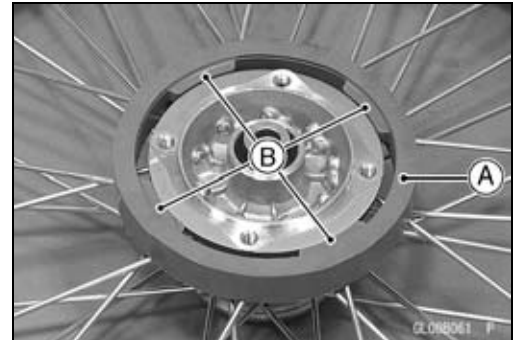

- Install the brake disc on the wheel so that the marked side [A] faces out.
- Apply a non-permanent locking agent to the brake disc mounting bolts.
- Tighten:

Torque - Brake Disc Mounting Bolts: 23 N·m (2.3 kgf·m, 17 ft·lb)

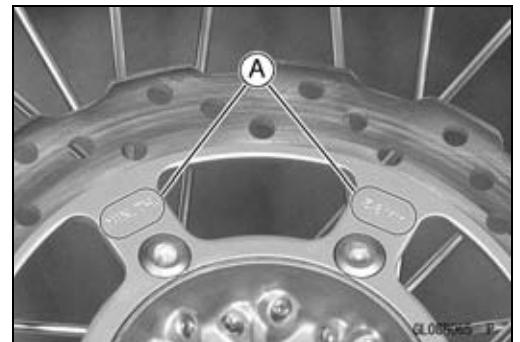

Brake Disc Wear

- Measure the thickness of each disc [A] at the point where it has worn the most.
 - ★ If the disc has worn past the service limit, replace it.
- Measuring Area [B]

Brake Discs Thickness

Standard:

Front:

KLX250S 3.35 ~ 3.65 mm (0.132 ~ 0.144 in.)

KLX250V 3.8 ~ 4.2 mm (0.15 ~ 0.17 in.)

Rear 4.30 ~ 4.70 mm (0.169 ~ 0.185 in.)

Service Limit:

Front:

KLX250S 2.8 mm (0.11 in.)

KLX250V 3.5 mm (0.14 in.)

Rear 3.8 mm (0.15 in.)

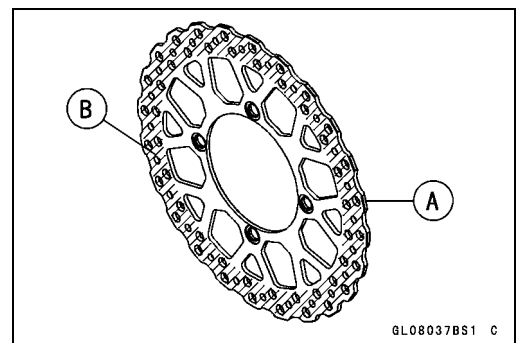

12-20 BRAKES

Brake Disc

Brake Disc Warp

- Raise the wheel off the ground with jack (see Front/Rear Wheel Removal in the Wheels/Tires chapter).

Special Tool - Jack: 57001-1238

- For front disc inspection, turn the handlebar fully to one side.
- Set up a dial gauge against the disc [A] as shown and measure disc runout, while turning [B] the wheel by hand.
- ★ If runout exceeds the service limit, replace the disc.

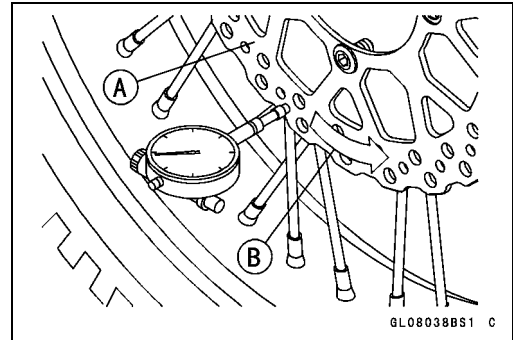

Disc Runout

Standard: TIR 0.12 mm (0.0047 in.) or less

Service Limit: TIR 0.3 mm (0.01 in.)

Brake Fluid

Brake Fluid Level Inspection

- Refer to the Brake Fluid Level Inspection in the Periodic Maintenance chapter.

Brake Fluid Change

- Refer to the Brake Fluid Change in the Periodic Maintenance chapter.

Brake Line Bleeding

The brake fluid has a very low compression coefficient so that almost all the movement of the brake lever or pedal is transmitted directly to the caliper for braking action. Air, however, is easily compressed. When air enters the brake lines, brake lever or pedal movement will be partially used in compressing the air. This will make the lever or pedal feel spongy, and there will be a loss in braking power.

⚠ WARNING

Air in the brake lines diminish braking performance and can cause an accident resulting in injury or death. If the brake lever or pedal has a soft or "spongy" feeling mushy when it is applied, there might be air in the brake lines or the brake may be defective. Do not operate the vehicle and service the brake system immediately.

NOTE

- *The procedure to bleed the front brake line is as follows. Bleeding the rear brake line is the same as for the front brake.*

- Remove the reservoir cap [A] and diaphragm.
- Fill the reservoir with fresh brake fluid to the upper level line in the reservoir.
- Slowly pump the brake lever several times until no air bubbles can be seen rising up through the fluid from the holes at the bottom of the reservoir.
- Bleed the air completely from the master cylinder by this operation.

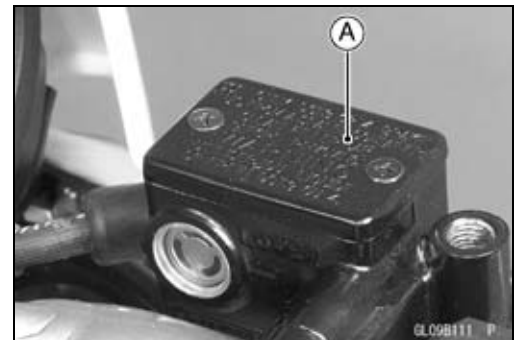

- Remove the rubber cap from the bleed valve [A] on the caliper.
- Attach a clear plastic hose [B] to the bleed valve, and run the other end of the hose into a container.

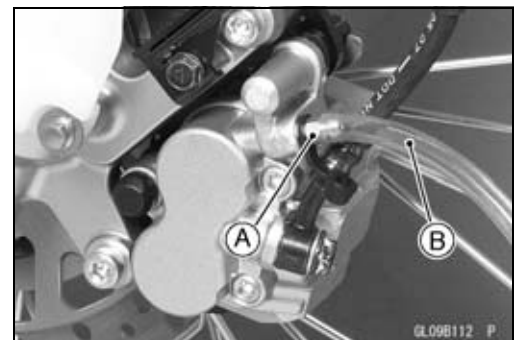

12-22 BRAKES

Brake Fluid

- Bleed the brake line and the caliper.
- Repeat this operation until no more air can be seen coming out into the plastic hose.
 1. Pump the brake lever until it becomes hard, and apply the brake and hold it [A].
 2. Quickly open and close [B] the bleed valve while holding the brake applied.
 3. Release the brake [C].

NOTE

- *The fluid level must be checked often during the bleeding operation and replenished with fresh brake fluid as necessary. If the fluid in the reservoir runs completely out any time during bleeding, the bleeding operation must be done over again from the beginning since air will have entered the line.*
- *Tap the brake hose lightly from the caliper to the reservoir for more complete bleeding.*
- Remove the clear plastic hose.
- Install the diaphragm and reservoir cap.
- Tighten:
 - Torque - Brake Master Cylinder Reservoir Cap Screws: 1.5 N·m (0.15 kgf·m, 13 in·lb)**
- Tighten the bleed valve, and install the rubber cap.
 - Torque - Caliper Bleed Valve: 7.8 N·m (0.80 kgf·m, 69 in·lb)**
- Check the fluid level (see Brake Fluid Level Inspection in the Periodic Maintenance chapter).
- After bleeding is done, check the brake for good braking power, no brake drag, and no fluid leakage.

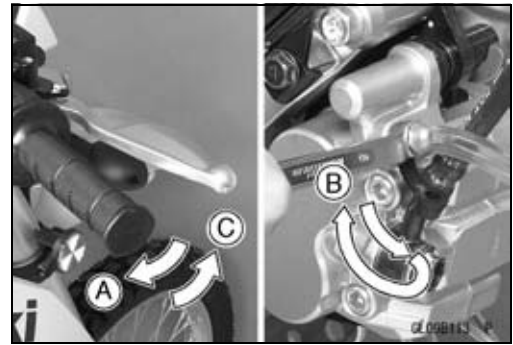

Brake Fluid

 WARNING

When working with the disc brake, observe the precautions listed below.

1. Never reuse old brake fluid.
2. Do not use fluid from a container that has been left unsealed or that has been open for a long time.
3. Do not mix two types and brands of fluid for use in the brake. This lowers the brake fluid boiling point and could cause the brake to be ineffective. It may also cause the rubber brake parts to deteriorate.
4. Don't leave the reservoir cap off for any length of time to avoid moisture contamination of the fluid.
5. Don't change the fluid in the rain or when a strong wind is blowing.
6. Except for the disc pads and disc, use only disc brake fluid, isopropyl alcohol, or ethyl alcohol for cleaning of the brake parts. Do not use any other fluid for cleaning these parts. Gasoline, engine oil, or any other petroleum distillate will cause deterioration of the rubber parts. Oil spilled on any part will be difficult to wash off completely and will eventually deteriorate the rubber used in the disc brake.
7. When handling the disc pads or disc, be careful that no disc brake fluid or any oil gets on them. Clean off any fluid or oil that inadvertently gets on the pads or disc with a high-flash point solvent. Do not use one which will leave an oily residue. Replace the pads with new ones if they cannot be cleaned satisfactorily.
8. Brake fluid quickly ruins painted surfaces; any spilled fluid should be completely wiped up immediately.
9. If any of the brake line fittings or the bleed valve is opened at any time, the **AIR MUST BE BLED FROM THE BRAKE LINE.**

12-24 BRAKES

Brake Hose

Brake Hose Removal/Installation

- Refer to the Brake Hose Replacement in the Periodic Maintenance chapter.

Brake Hose Inspection

- Refer to the Brake Hose Damage and Installation Condition Inspection in the Periodic Maintenance chapter.

Suspension

Table of Contents

Exploded View	13-2
Specifications	13-6
Special Tools	13-8
Front Fork	13-9
Front Fork Damping Force Adjustment	13-9
Front Fork Removal	13-9
Front Fork Installation	13-10
Front Fork Oil Change	13-10
Front Fork Disassembly	13-13
Front Fork Assembly	13-14
Inner Tube, Outer Tube Inspection	13-16
Fork Spring Inspection	13-16
Dust Seal/Oil Seal Inspection	13-16
Guide Bushings Inspection	13-17
Rear Shock Absorber	13-18
Rebound Damping Adjustment	13-18
Compression Damping Adjustment	13-18
Spring Preload Adjustment	13-19
Rear Shock Absorber Removal	13-19
Rear Shock Absorber Installation	13-20
Rear Shock Absorber Scrapping	13-21
Swingarm	13-22
Swingarm Removal	13-22
Swingarm Installation	13-23
Swingarm Bearing Removal	13-23
Swingarm Bearing Installation	13-23
Needle Bearing, Sleeve Inspection	13-23
Tie-rod, Rocker Arm	13-24
Tie-rod Removal	13-24
Tie-rod Installation	13-24
Rocker Arm Removal	13-24
Rocker Arm Installation	13-24
Tie-Rod and Rocker Arm Bearing Removal	13-25
Tie-Rod and Rocker Arm Bearing Installation	13-26
Rocker Arm Sleeve Inspection	13-26
Needle Bearing, Sleeve Inspection	13-27
Rocker Arm Pivot Shaft Bent Inspection	13-27

13-2 SUSPENSION

Exploded View

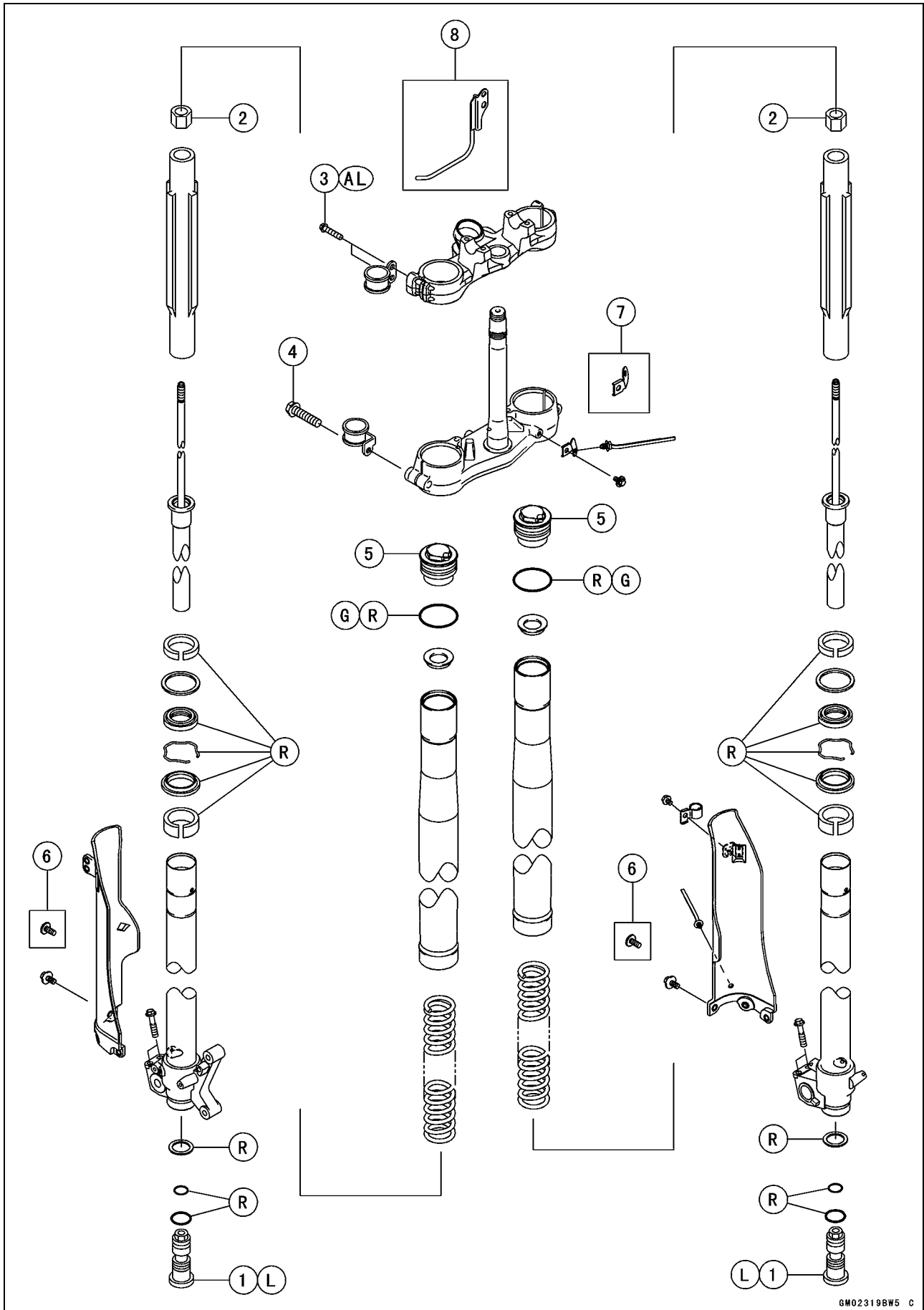

Exploded View

No.	Fastener	Torque			Remarks
		N·m	kgf·m	ft·lb	
1	Front Fork Cylinder Valve Assys	55	5.6	40	L
2	Piston Rod Nuts	15	1.5	11	
3	Upper Front Fork Clamp Bolts	20	2.0	15	AL
4	Lower Front Fork Clamp Bolts	25	2.5	18	
5	Front Fork Top Plugs	30	3.0	22	

6. BR and EUR Models

7. KLX250V Model

8. KLX250S9F (TH)/V9F (TH)

AL: Tighten the two upper front fork clamp bolts alternately two times to ensure even tightening torque.

G: Apply grease.

L: Apply a non-permanent locking agent.

R: Replacement Parts

13-4 SUSPENSION

Exploded View

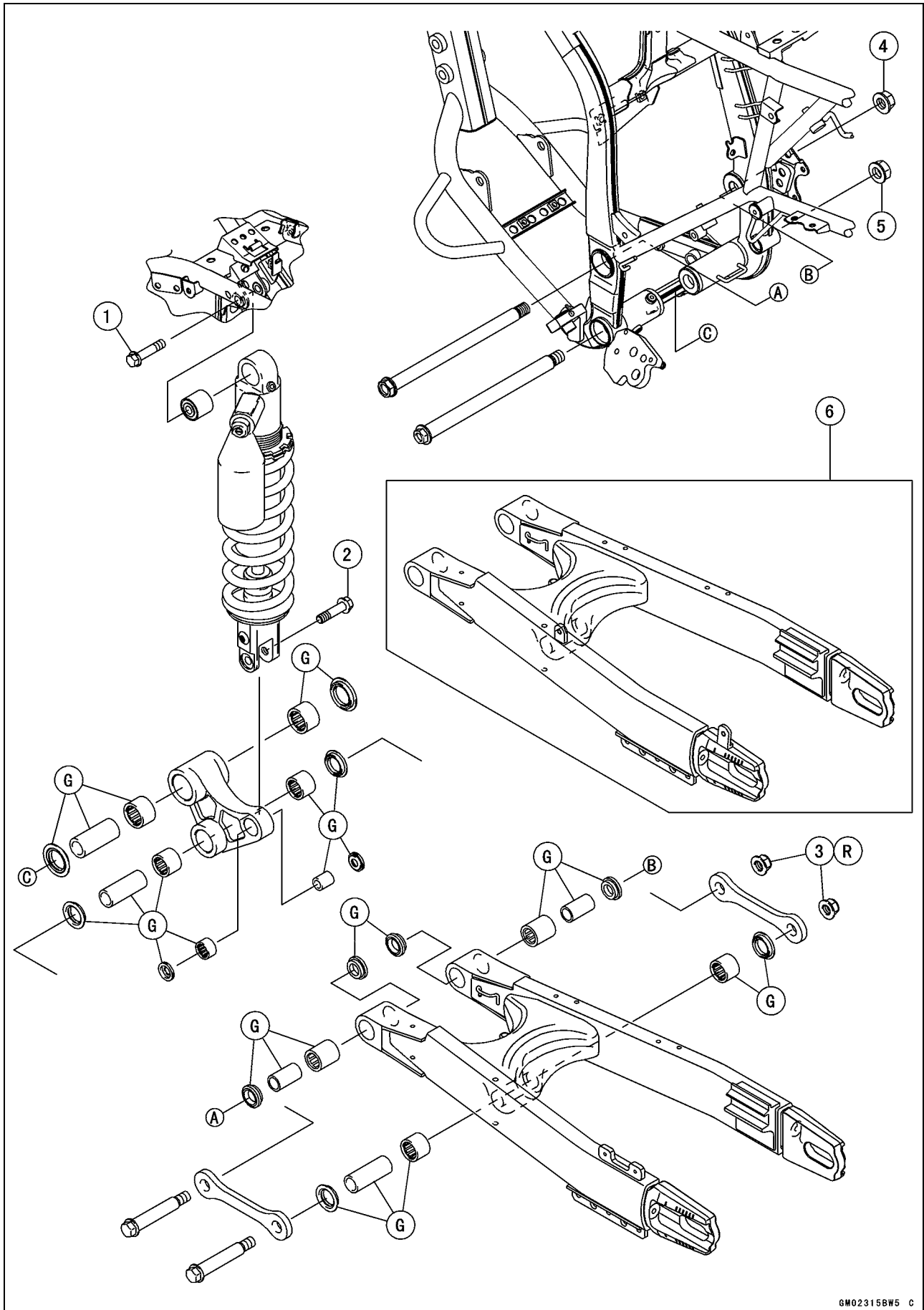

Exploded View

No.	Fastener	Torque			Remarks
		N·m	kgf·m	ft·lb	
1	Upper Rear Shock Absorber Bolt	39	4.0	29	
2	Lower Rear Shock Absorber Bolt	39	4.0	29	
3	Tie-rod Nuts	83	8.5	61	R
4	Swingarm Pivot Shaft Nut	88	9.0	65	
5	Rocker Arm Pivot Shaft Nut	98	10	72	

6. BR and EUR Models

G: Apply grease.

R: Replacement Parts

13-6 SUSPENSION

Specifications

Fastener	Standard	Service Limit
Front Fork		
Air Pressure	Atmospheric Pressure (Non-adjustable)	— — —
Fork Oil:		
Viscosity	KHL15-10 (KAYABA01) or equivalent Approx. 450 mL (15.2 US oz.) (when changing oil)	— — —
Amount:		
KLX250S	531 ±4 mL (18.0 ±0.1 US oz.) (after disassembly and completely dry)	— — —
KLX250V	527 ±4 mL (17.8 ±0.1 US oz.) (after disassembly and completely dry)	— — —
Fork Oil Level:		
KLX250S	101 ±2 mm (3.98 ±0.08 in.) (fully compressed, without fork spring, below from the top of the inner tube)	— — —
KLX250V	104 ±2 mm (4.09 ±0.08 in.) (fully compressed, without fork spring, below from the top of the inner tube)	— — —
Compression Damper Setting	12 clicks counterclockwise	(Adjustable Range) 16 clicks
(from the seated position adjuster turned fully clockwise)		
Spring Free Length:		
KLX250S	412.3 mm (16.23 in.)	404 mm (15.9 in.)
KLX250V	387.3 mm (15.25 in.)	380 mm (15.0 in.)
Rear Suspension (Uni-Trak):		
Rear Shock Absorber		
Rebound Damper Setting (from the seated position adjuster turned fully clockwise):		
KLX250S	12 clicks counterclockwise	(Adjustable Range) 20 clicks
KLX250V	8 clicks counterclockwise	(Adjustable Range) 20 clicks
Spring Preload Setting (Adjusting nut position from the center of the mounting hole upper):		
KLX250S	107.5 mm (4.232 in.)	101 ~ 123 mm (3.98 ~ 4.84 in.)
KLX250V	119.5 mm (4.705 in.)	111 ~ 133 mm (4.37 ~ 5.24 in.)

Specifications

<p>Gas Reservoir Compression Damper Setting (from the seated position adjuster turned fully clockwise) Gas Pressure</p>	<p>16 clicks counterclockwise 980 kPa (10 kgf/cm², 142 psi)</p>	<p>(Adjustable Range) 20 clicks - - -</p>
<p>Tie-rod, Rocker Arm Sleeve Outside Diameter: Rocker Arm Shaft Runout</p>	<p>24.987 ~ 25.000 mm (0.98373 ~ 0.98425 in.) 21.987 ~ 22.000 mm (0.86563 ~ 0.86614 in.) 15.989 ~ 16.000 mm (0.62949 ~ 0.62992 in.) TIR 0.1 mm (0.004 in.) or less</p>	<p>24.85 mm (0.9783 in.) 21.85 mm (0.8602 in.) 15.85 mm (0.6240 in.) TIR 0.2 mm (0.008 in.)</p>

13-8 SUSPENSION

Special Tools

Oil Seal & Bearing Remover:
57001-1058

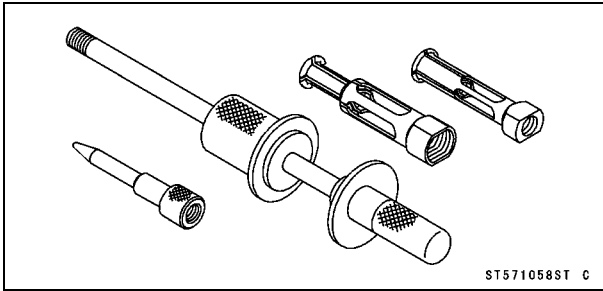

ST571058ST C

Fork Spring Holder:
57001-1286

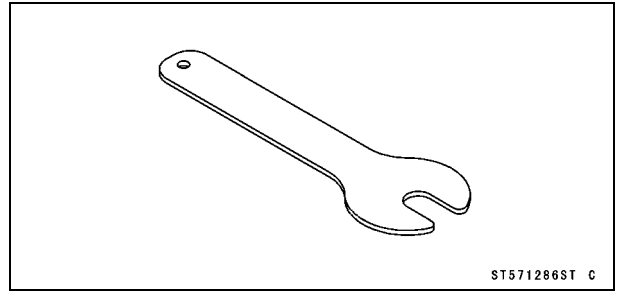

ST571286ST C

Hook Wrench R37.5, R42:
57001-1101

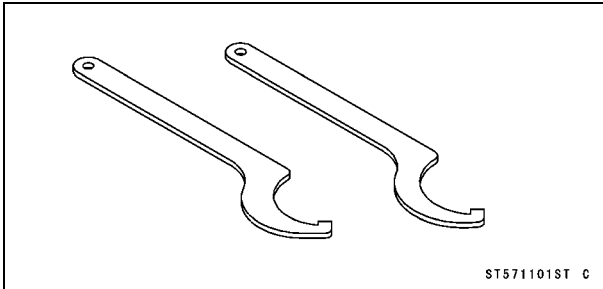

ST571101ST C

Fork Cylinder Holder:
57001-1287

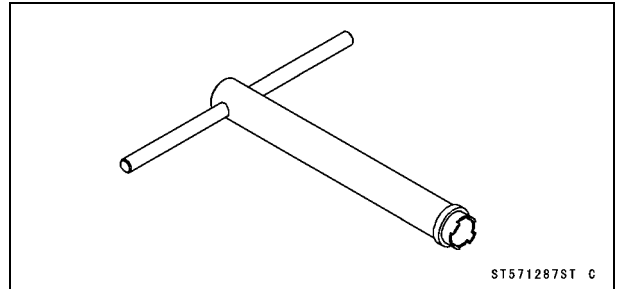

ST571287ST C

Bearing Driver Set:
57001-1129

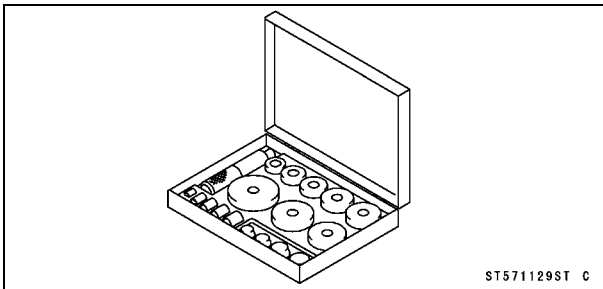

ST571129ST C

Fork Oil Level Gauge:
57001-1290

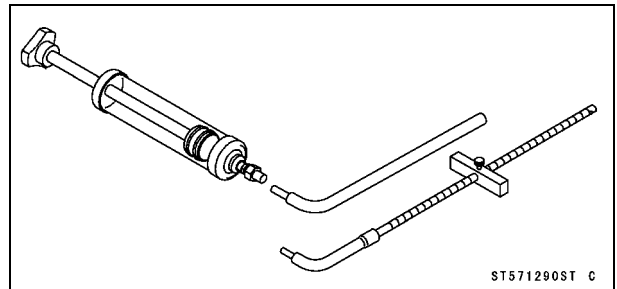

ST571290ST C

Fork Outer Tube Weight:
57001-1218

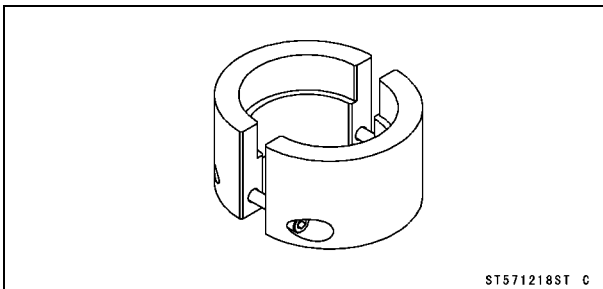

ST571218ST C

Fork Piston Rod Puller, M10 × 1.0:
57001-1298

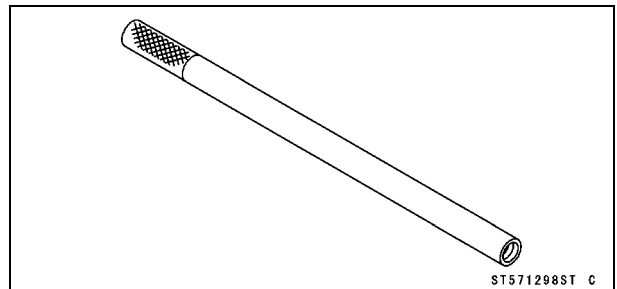

ST571298ST C

Jack:
57001-1238

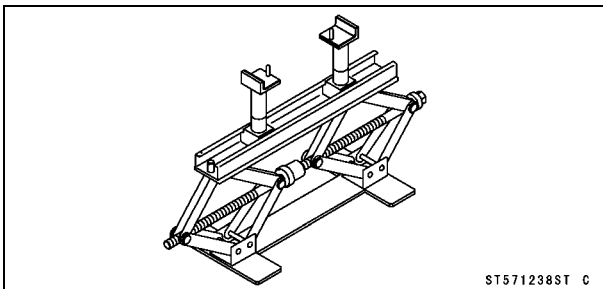

ST571238ST C

Fork Oil Seal Driver, $\phi 43$:
57001-1530

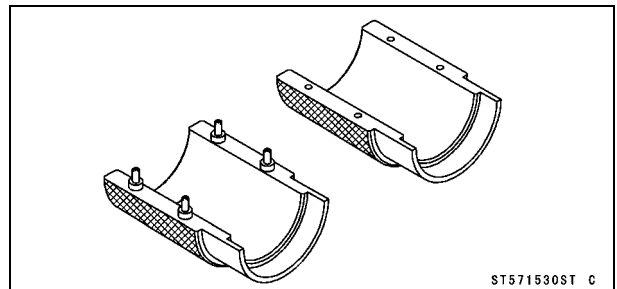

ST571530ST C

Front Fork

Front Fork Damping Force Adjustment

- Turn the adjuster [A] of the front fork cylinder valve with a flat head screw driver to adjust compression damping to a preference condition.



NOTICE

The left and right fork legs must have the same shock damping.

Seated positions adjuster turned fully clockwise [A].

Compression Damping Adjuster Setting

Standard: 12 clicks [B]

Harder [C]

Softer [D]

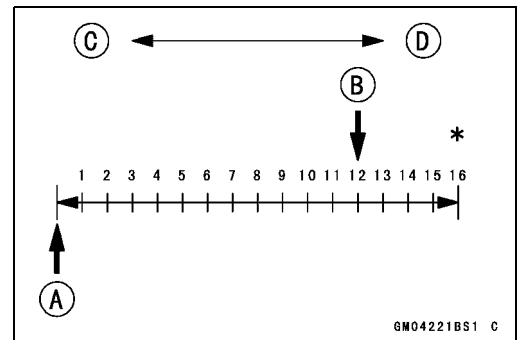

NOTE

○Although you can turn the adjuster beyond the adjustable range, effecting no changes to damping force, use it within the adjustable range.

Front Fork Removal

- Remove:
 - Bolts (Both Sides) [A]
 - Front Fork Protectors [B]
- Place the jack under the frame so that the front wheel off the ground.

Special Tool - Jack: 57001-1238

⚠ WARNING

Be sure to put the rear wheel on the ground when removing the front wheel, or the motorcycle may fall over. It could cause an accident and injury.

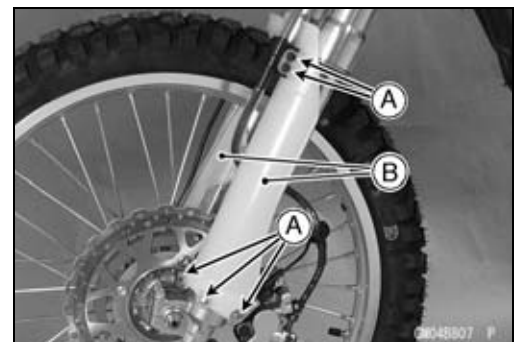

- Remove:
 - Front Wheel (see Front Wheel Removal in the Wheels/Tires chapter)
- Loosen the upper front fork clamp bolts [A].
 - If the front fork is to be disassembled, remove the handlebar to loosen the top plug [B].
- Loosen the lower front fork clamp bolt [C].
- With a twisting motion, work the fork down and out.

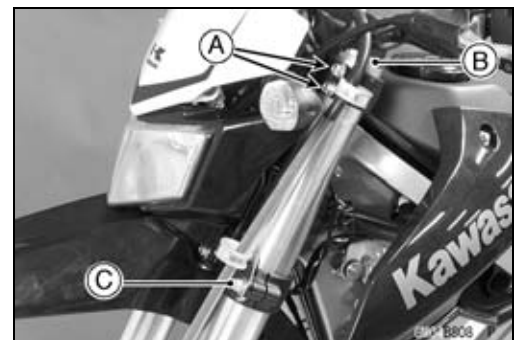

13-10 SUSPENSION

Front Fork

Front Fork Installation

- Install the front fork so that the distance between the top end [A] of the outer tube and the upper surface [B] of the steering stem head becomes 6 mm (0.24 in.) [C].
- Tighten the lower front fork clamp bolt and top plug.

Torque - Lower Front Fork Clamp Bolts: 25 N·m (2.5 kgf·m, 18 ft·lb)

Front Fork Top Plug: 30 N·m (3.0 kgf·m, 22 ft·lb)

- Tighten:

Torque - Upper Front Fork Clamp Bolts: 20 N·m (2.0 kgf·m, 15 ft·lb)

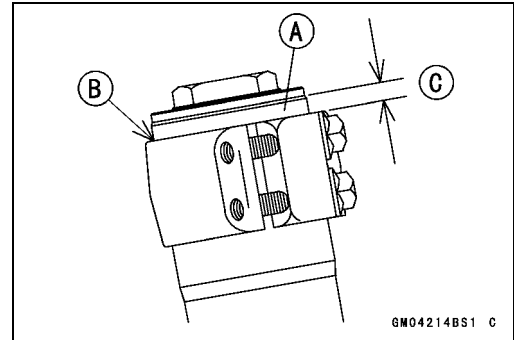

NOTE

- Tighten the top plug before tightening the upper front fork clamp bolts.
- Tighten the two upper front fork clamp bolts alternately two times to ensure even tightening torque.

- Install the removed parts (see appropriate chapters).

Front Fork Oil Change

- Remove the front fork (see Front Fork Removal).
- Hold the outer tube vertically and hold the inner tube lower end in a vice.
- Remove the top plug [A] from the outer tube [B] and slowly slide down the outer tube.

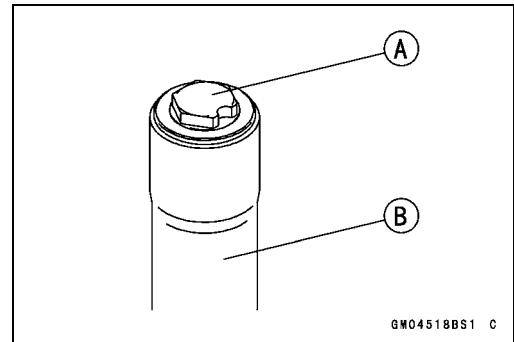

- Push down the fork spring [A] to engage the fork spring holder [B] below the piston rod nut [C].

Special Tool - Fork Spring Holder: 57001-1286

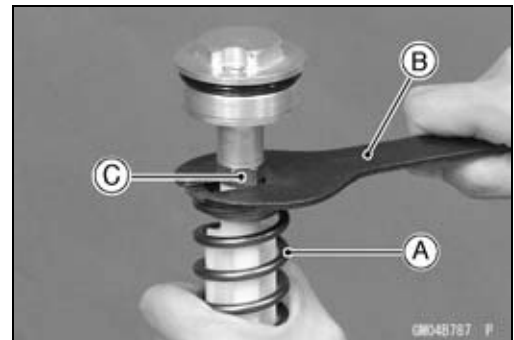

- Using a wrench, loosen the piston rod nut and remove the top plug [A].
- Push down the fork spring [B] to remove the fork spring holder [C], and then remove the fork spring and spring seat [C].

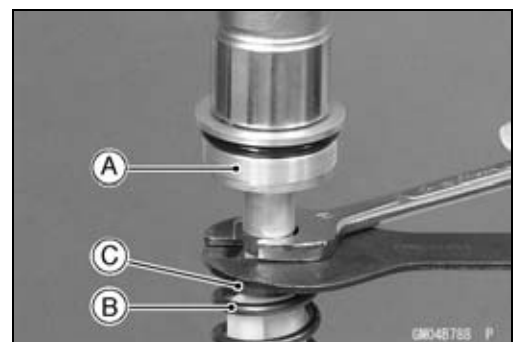

Front Fork

- Remove the fork tube from the vise, and drain the fork oil into a suitable container.

NOTE

○ To drain off fork oil, hold the fork tube downward and move the piston rod [A] up and down, more than ten times

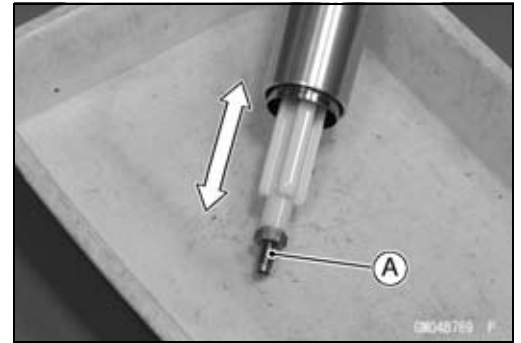

- Hold the fork tube upright in a vise, press the outer tube [A] and the piston rod all the way down.
- Pour in the specified type of oil.

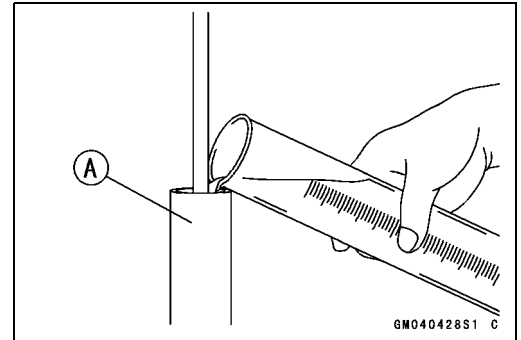

Fork Oil

Viscosity: KHL15-10 (KAYABA01) or equivalent

Amount (per side):
When chaining oil Approx. 450 mL (15.2 US oz.)

After disassembly, completely dry:
KLX250S 531 ±4 mL (18.0 ±0.1 US oz.)
KLX250V 527 ±4 mL (17.8 ±0.1 US oz.)

- Using the fork piston rod puller [A], move the piston rod [B] up and down more than 10 times in order to discharge all the air from the fork oil.

Special Tool - Fork Piston Rod Puller, M10 × 1.0: 57001-1298

- Remove the fork piston rod puller.

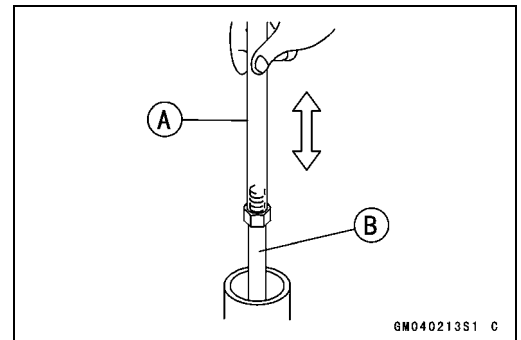

13-12 SUSPENSION

Front Fork

- Pump the outer tube up and down several times to discharge the air between the outer tube and inner tube.
- Wait until the oil level stabilizes.
- Measure the distance from the top of the inner tube to the fork oil, using the fork oil level gauge [A].

Special Tool - Fork Oil Level Gauge: 57001-1290

- With the front fork fully compressed and without fork spring, insert the gauge tube into the inner tube [B] and position the stopper [C] across the top end [D] of the inner tube.
- Set the gauge stopper so that its lower side shows the oil level distance specified [E].
[F] Outer Tube

Oil Level (Fully compressed, without spring)

Standard:

KLX250S **101 ±2 mm (3.98 ±0.08 in.)**

KLX250V **104 ±2 mm (4.09 ±0.08 in.)**

- Pull the handle slowly to pump out the excess oil until the oil no longer comes out.
- ★ If no oil is pumped out, there is insufficient oil in the inner tube. Pour in enough oil, then pump out the excess oil.

- Install the fork piston rod puller [A] onto the push rod, and slowly pull up the fork piston rod puller.

Special Tool - Fork Piston Rod Puller, M10 × 1.0: 57001-1298

NOTE

○ Be careful for fork oil spillage from the inner tube.

- Insert the fork spring into the inner tube, and set the spring guide on the spring.
- Push down the fork spring to engage the fork spring holder [B] below the piston rod nut [C].

Special Tool - Fork Spring Holder: 57001-1286

- Remove the fork piston rod puller.
- Replace the O-ring [A] on the top plug with a new one.
- Install the top plug on the piston rod.
- Holding the top plug with a wrench, tighten the piston rod nut [B] against the top plug.

Torque - Piston Rod Nut: 15 N·m (1.5 kgf·m, 11 ft·lb)

- Push down the fork spring to remove the fork spring holder.
- Lift up the outer tube and install the top plug.
- Tighten:

Torque - Front Fork Top Plug: 30 N·m (3.0 kgf·m, 22 ft·lb)

- Install the front fork (see Front Fork Installation).

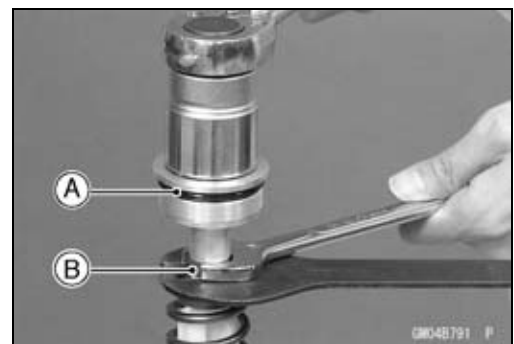
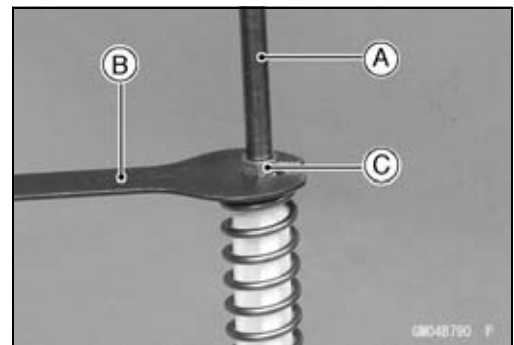
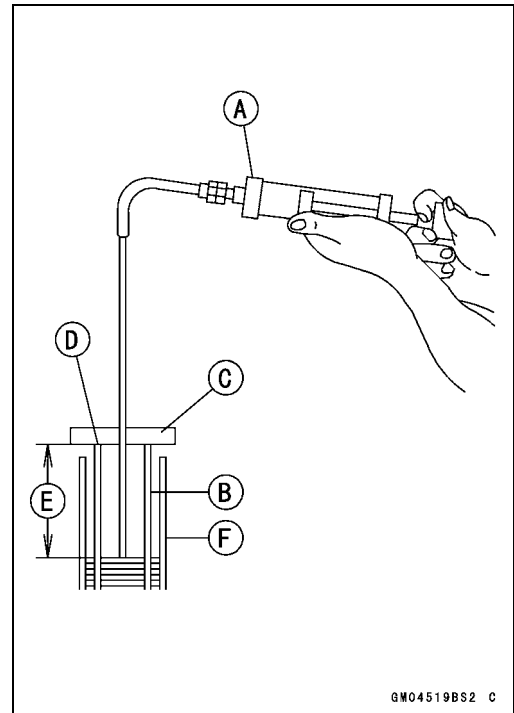

Front Fork

Front Fork Disassembly

- Drain the fork oil (see Front Fork Oil Change).
- Remove:
 - Piston Rod Nut [A]
 - Spring Guide [B]

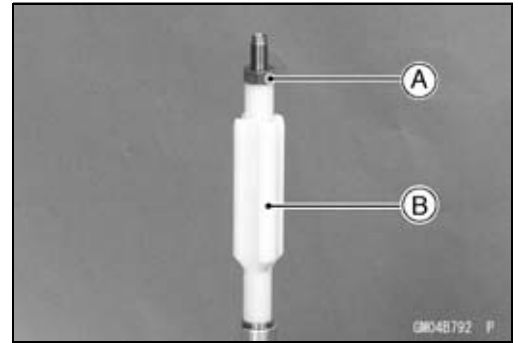

- Hold the outer tube sideways and hold the inner tube in a vice.
- Push the outer tube as far as it will go. Hold the cylinder unit [A] with the fork cylinder holder [B], and loosen the cylinder valve assy [C]. Then remove the cylinder valve assy and gasket from the inner tube.

Special Tool - Fork Cylinder Holder: 57001-1287

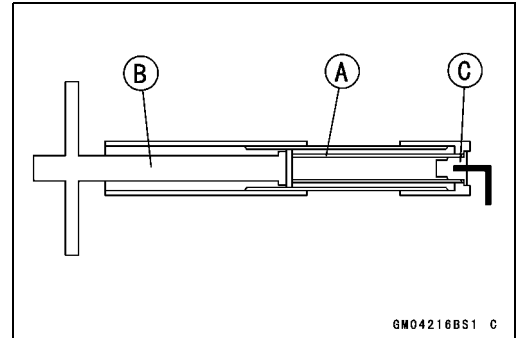

- [A] Inner Tube
- [B] Cylinder Valve Assy
- [C] Gasket

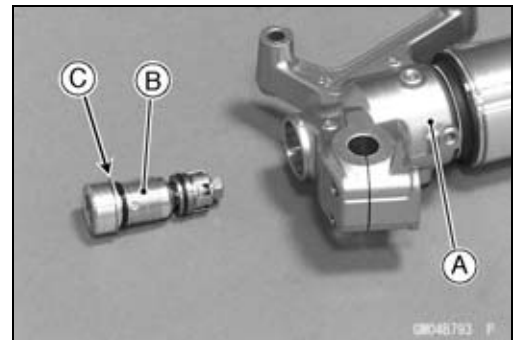

- Remove the piston rod [A] and cylinder unit [B] from the inner tube [C].

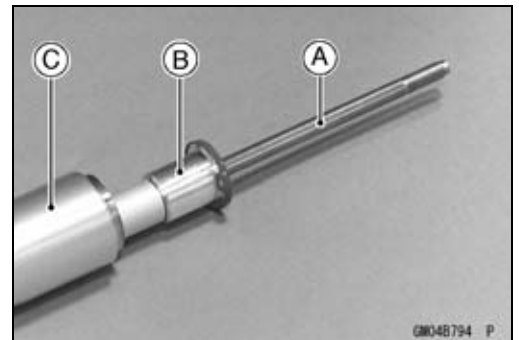

- Separate the inner tube from the outer tube as follows:
 - Pull up the dust seal [A].
 - Remove the fork tube from the vise.

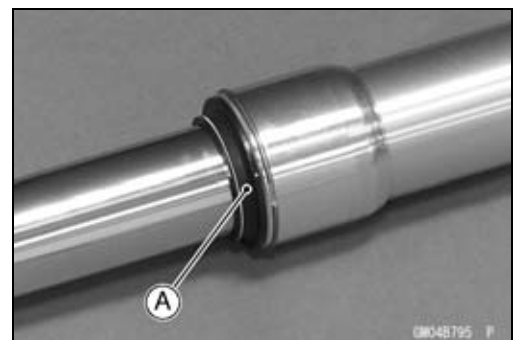

13-14 SUSPENSION

Front Fork

○Remove the retaining ring [A] from the outer tube.



○Holding the inner tube [A] by hand, pull the outer tube [B] several times to pull out the outer tube.

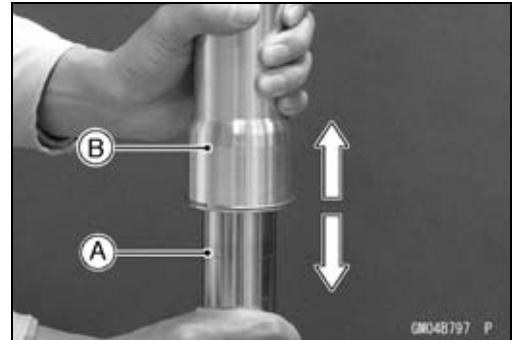

NOTE

○If the outer tube does not detach easily, set the fork outer tube weight [A] onto it to separate the inner and outer tubes.

Special Tool - Fork Outer Tube Weight: 57001-1218

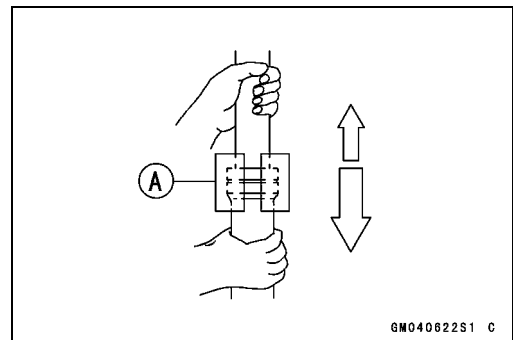

- Remove the following parts from the inner tube.
 - Guide Bushings [A]
 - Washer [B]
 - Oil Seal [C]
 - Retaining Ring [D]
 - Dust Seal [E]

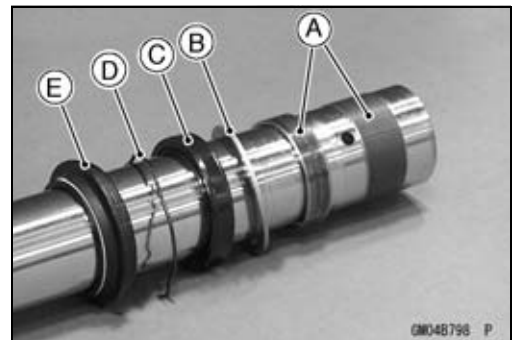

Front Fork Assembly

- Replace the following parts with new ones.
 - Dust Seals [A]
 - Retaining Ring [B]
 - Oil Seal [C]
 - Guide Bushings [D]

NOTE

○Since the inner tube guide bush groove has an edge [F], protect the oil seal lip from damages by placing a vinyl bag [E] over the inner tube in assembling an oil seal.

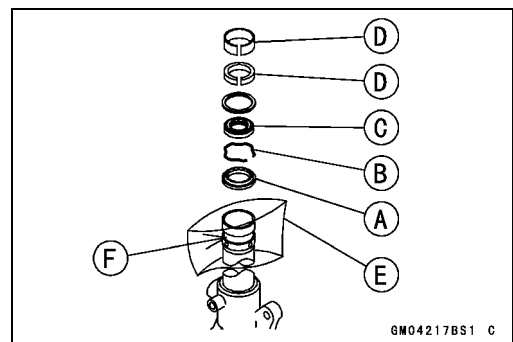

Front Fork

- Insert the spring band of the dust seal, dust seal, oil seal, washer and guide bush to the inner tube and set the guide bushing to the inner tube.
- When assembling the outer tube guide bushings [A], hold the washer [B] against the guide bushing and tap the washer with the fork oil seal driver [C] until it stops.

Special Tool - Fork Oil Seal Driver, $\phi 43$: 57001-1530

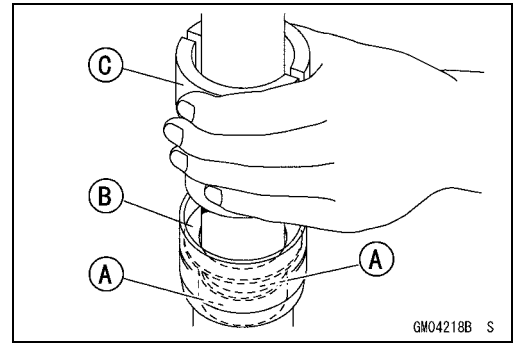

- Using the fork oil seal driver, press in the oil seal [D] until it is bottomed.
- Make the oil seal end with the protruding lip [E] face upward.

Special Tool - Fork Oil Seal Driver, $\phi 43$: 57001-1530

- Install the retaining ring.
- Push the dust seal into the outer tube.
- Set the spring band on the dust seal.

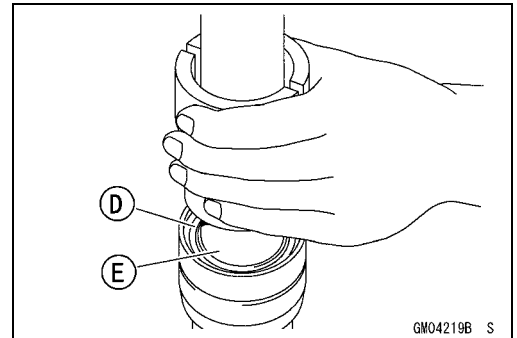

- Replace the O-rings [A] and gasket [B] on the cylinder valve assy [C] with new ones.
- Apply non-permanent locking agent to the threads [D] of the cylinder valve assy (Allen bolt).

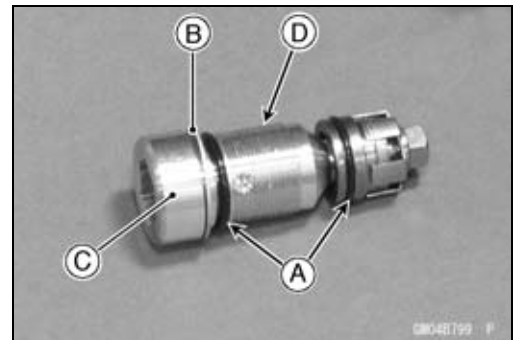

- Hold the cylinder unit [A] by using the fork cylinder holder [B], install and tighten the cylinder valve assy [C].

Special Tool - Fork Cylinder Holder: 57001-1287

Torque - Front Fork Cylinder Valve Assy: 55 N·m (5.6 kgf·m, 40 ft·lb)

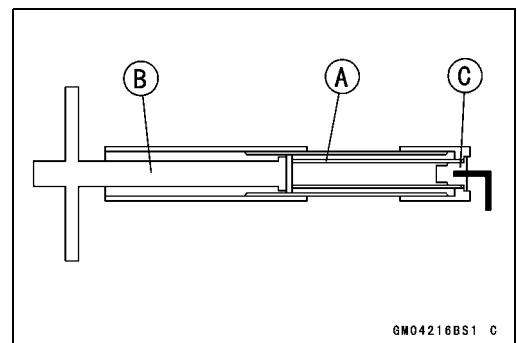

- Hold the outer tube vertically and hold the inner tube lower end in a vice.
- Set the spring guide [A] onto the push rod with the tapered end [B] facing downward.
- Install the piston rod nut [C] on the spring guide.
- Pour in the specified type of oil (see Fork Oil Change).

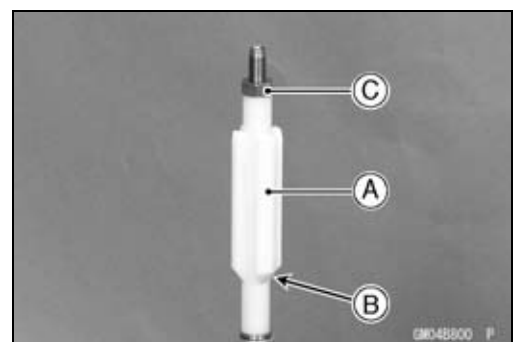

13-16 SUSPENSION

Front Fork

Inner Tube, Outer Tube Inspection

- Visually inspect the inner tube [A], and repair any damage.
- Nick or rust damage can sometimes be repaired by using a wet-stone to remove sharp edges or raised areas which cause seal damage.
- ★ If the damage is not repairable, replace the inner tube. Since damage to the inner tube damages the oil seal, replace the oil seal whenever the inner tube is repaired or replaced.

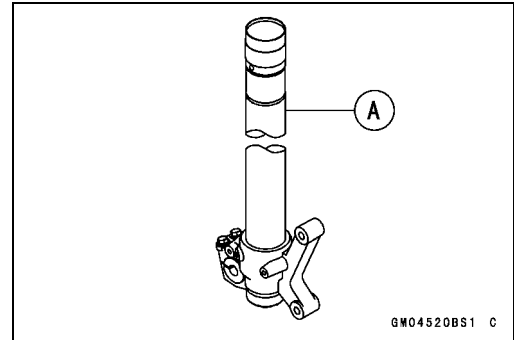

NOTICE

If the inner tube is badly bent or creased, replace it. Excessive bending, followed by subsequent straightening, can weaken the inner tube.

- Temporarily assemble the inner tube [A] and outer tube [B], and pump [C] them back and forth manually to check for smooth operation.
- ★ If you feel binding or catching, the inner and outer tubes must be replaced.

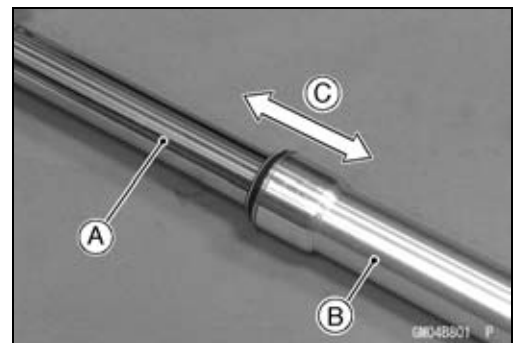

WARNING

A straightened inner or outer fork tube may fall in use, possibly causing an accident resulting in serious injury or death. Replace a badly bent or damaged inner or outer tube and inspect the other tube carefully before reusing it.

Fork Spring Inspection

- Measure the free length [B] of the fork spring [A].
- If the measurement is less than the service limit, replace the spring. If a large difference is observed in free length due to dimensional inconsistency, change both right and left ones, as this impairs the stability of vehicle control.

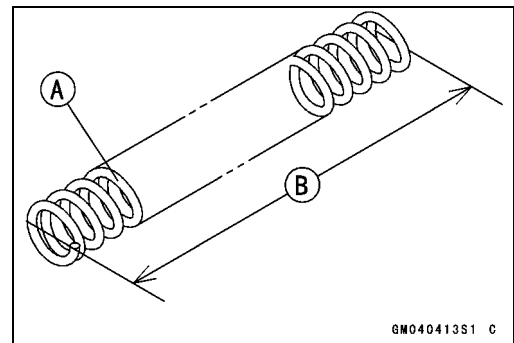

Fork Spring Free Length

Standard:

KLX250S	412.3 mm (16.23 in.)
KLX250V	387.3 mm (15.25 in.)

Service Limit:

KLX250S	404 mm (15.9 in.)
KLX250V	380 mm (15.0 in.)

Dust Seal/Oil Seal Inspection

- Inspect the dust seal [A] for any signs of deterioration or damage.
- ★ If it shows any signs of deterioration or damage, replace it with a new one.
- If removed, be sure to replace the oil seal [B] with a new one.

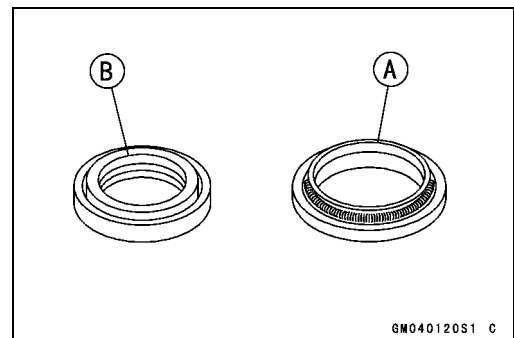

Front Fork

Guide Bushings Inspection

- Visually inspect the guide bushings [A], and replace them if necessary.

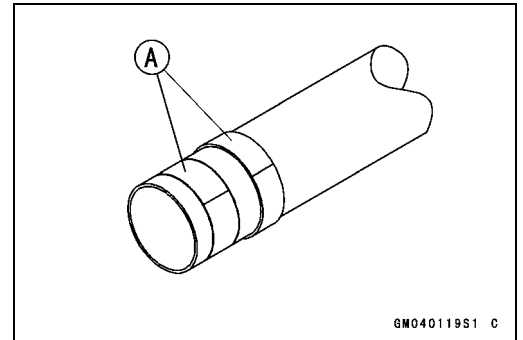

13-18 SUSPENSION

Rear Shock Absorber

Rebound Damping Adjustment

- Turn the rebound damping adjuster [A] on the rear shock absorber lower end with a screwdriver until you feel a click.
- ★ If the damper setting feels too soft or too stiff, adjust it in accordance with the following table.

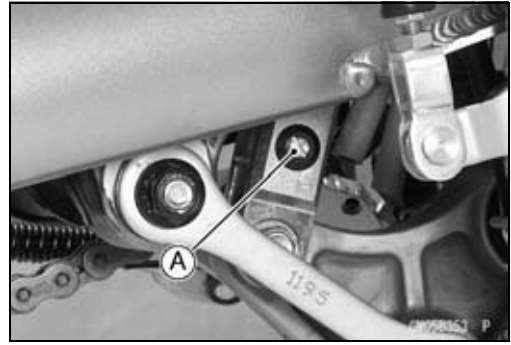

Seated position: adjuster turned fully clockwise [A].

Rebound Damping Adjuster Setting

Standard:

KLX250S **12 clicks [B]**

KLX250V **8 clicks [C]**

Softer (Counterclockwise) [D]

Harder (Clockwise) [E]

*: Number of turns counterclockwise usable range - 20 or more.

Counterclockwise from the fully seated position.

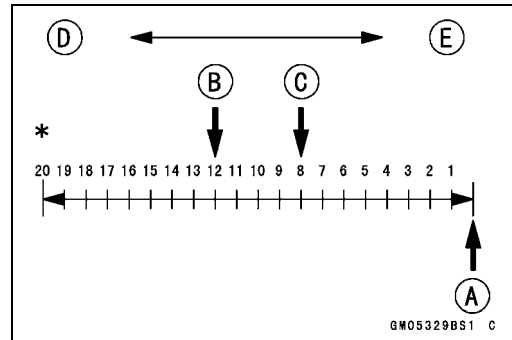

NOTE

○ Adjustment of the rebound damping adjuster for the rear suspension will slightly affect the compression damping force. Always make any damping adjustments in small steps and test their effects before using them in competition.

Compression Damping Adjustment

- Adjust the compression damping, turn the compression damping adjuster [A] with a screwdriver.
- ★ If the damping feels too soft or too stiff, adjust it in accordance with the following table.



Seated position: adjuster turned fully clockwise [A]

Compression Damping Adjuster Setting

Standard: **16 clicks [B]**

Softer (counterclockwise) [C]

Harder (clockwise) [D]

* : Number of turns counterclockwise usable range - 20 clicks or more.

Counterclockwise from the fully seated position.

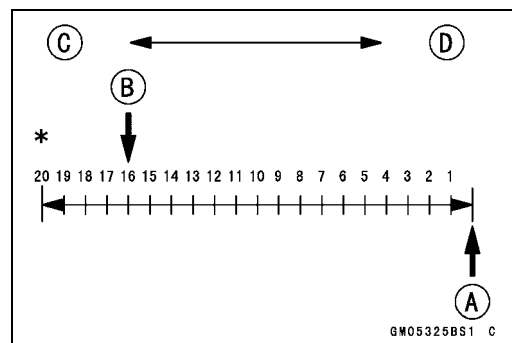

NOTE

○ Adjustment of the compression damping adjuster for the rear suspension will slightly affect the rebound damping force. Always make any damping adjustments in small steps and test their effects before using them in competition.

Rear Shock Absorber

Spring Preload Adjustment

- Remove the rear shock absorber (see Rear Shock Absorber Removal).
- Hold the lower of the rear shock absorber with a vise.
- Using the hook wrenches [A], loosen the locknut [B] and turn the adjusting nut [C] as required. When you turn the adjustment nut upward, initial load will decrease; when you turn it downward, initial load will increase.

Special Tool - Hook Wrench R37.5, R42: 57001-1101

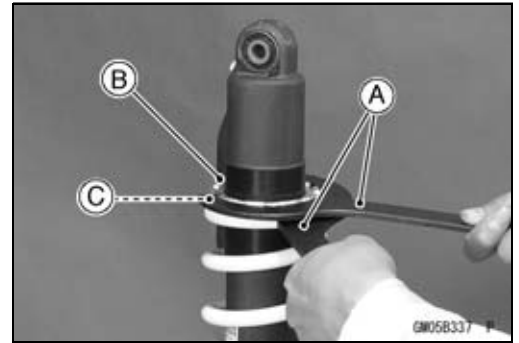

Spring Preload Adjustment

(Adjusting nut position at the lower surface [A] from the center of the mounting hole)

Standard:

KLX250S **107.5 mm (4.232 in.)**

KLX250V **119.5 mm (4.705 in.)**

Adjustable Range:

KLX250S **101 ~ 123 mm (3.98 ~ 4.84 in.)**

KLX250V **111 ~ 133 mm (4.37 ~ 5.24 in.)**

- After adjusting, move the spring up and down to make sure that the spring is seated.
- Tighten the locknut securely.
- Install the rear shock absorber.

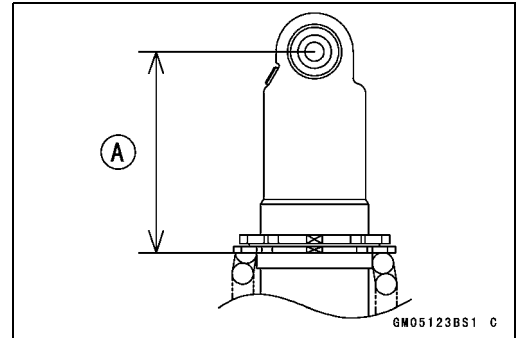

Rear Shock Absorber Removal

- Using a jack, raise the rear wheel off the ground.
- Special Tool - Jack: 57001-1238**
- Squeeze the brake lever slowly and hold it with a band [A].



⚠ WARNING

Be sure to hold the front brake when removing the shock absorber, or the motorcycle, may fall over. It could cause an accident and injury.

- Remove the following parts.
Left Side Cover (see Side Cover Removal in the Frame chapter)
Front Tie-rod Nut and Bolt (see Tie-rod Removal)
Rear Fender Flap Front (see Rear Fender Flap Front Removal in the Frame chapter)

NOTICE

When pulling out the mounting bolt, lift the rear wheel slightly. Forcing or tapping on bolt could damage the mounting bolt, sleeve, and bearing.

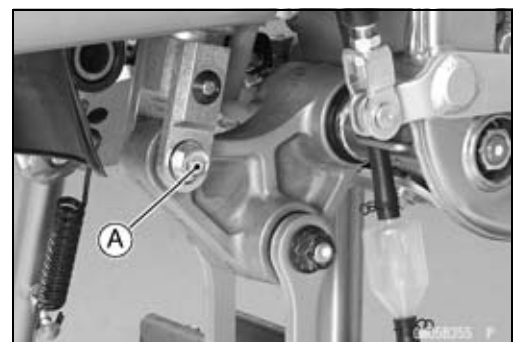

- Remove the lower rear shock absorber mounting bolt [A].

13-20 SUSPENSION

Rear Shock Absorber

- Using the available jack [A], lift the rear wheel as shown.

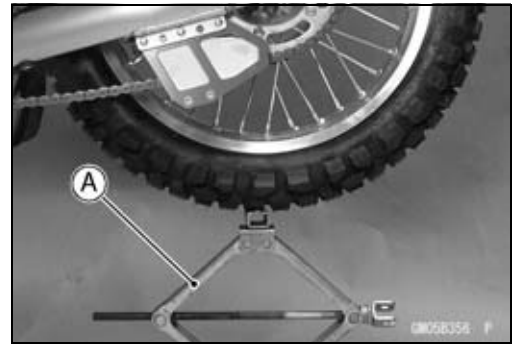

- Remove the upper rear shock absorber bolt [A], and remove the rear shock absorber [B] to the left side.

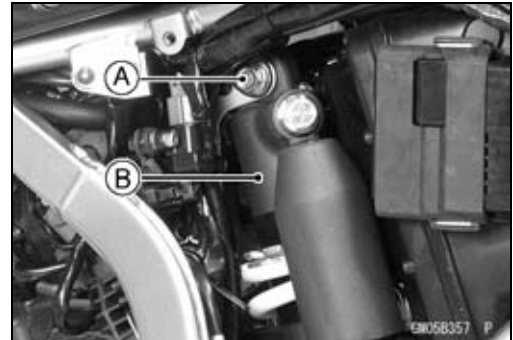

Rear Shock Absorber Installation

- Apply grease to the needle bearings and inside of the oil seals.
- Replace the tie-rod nut with a new one.
- Tighten:

**Torque - Rear Shock Absorber Bolts (Upper, Lower): 39
N·m (4.0 kgf·m, 29 ft·lb)**

Tie-rod Nut (Rear): 83 N·m (8.5 kgf·m, 61 ft·lb)

Rear Shock Absorber

Rear Shock Absorber Scrapping**⚠ WARNING**

Pressurized nitrogen may explode when heated. The rear shock contains nitrogen gas. To avoid an explosion, do not incinerate the shock body without first releasing the nitrogen and removing the shraeder valve.

- Remove the shock absorber (see Rear Shock Absorber Removal).
- Remove the valve cap [A] and release the nitrogen gas completely from the gas reservoir.
- Remove the valve.

⚠ WARNING

Pressurized gas can cause injury. Do not point the valve toward your face or body.

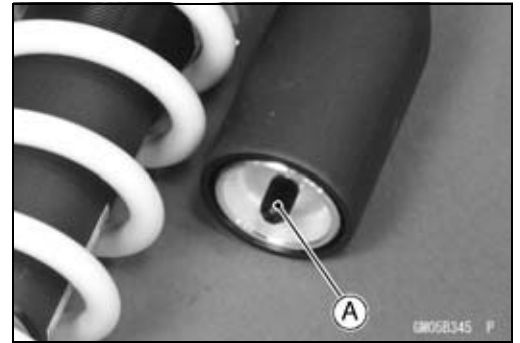

13-22 SUSPENSION

Swingarm

Swingarm Removal

- Remove:
 - Rear Wheel (see Rear Wheel Removal in the Wheels/Tires chapter)
 - Rear Fender Flap Front (see Rear Fender Flap Front Removal in the Frame chapter)
 - Tie-rod Bolt and Nut (Rear) [A]
 - Swingarm Pivot Shaft Nut [B]

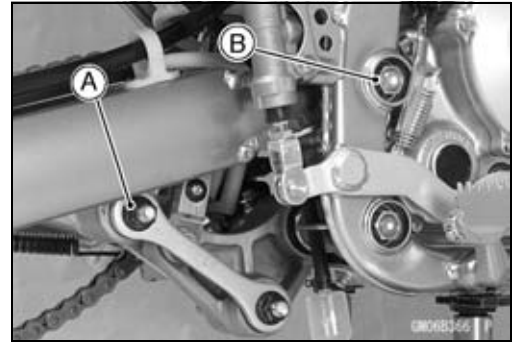

- Remove:
 - Bolts [A]
 - Chain Guide [B]
 - Bolt [C] and Nuts
 - Chain Slipper [D]

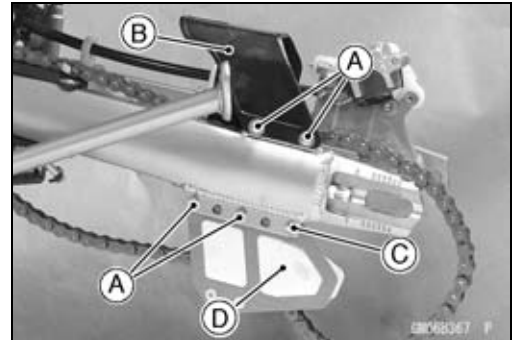

- EUR model, as shown in the figure.

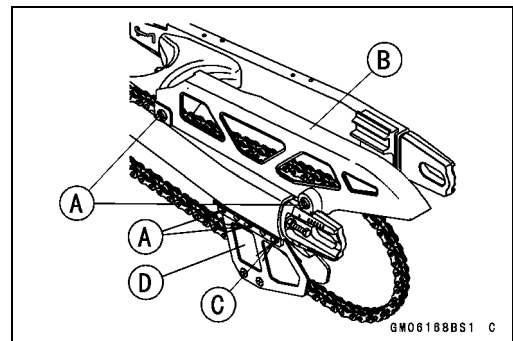

- Remove the brake hose guides [A].
- Remove the rear brake hose [B] with the caliper [C] from the swingarm.

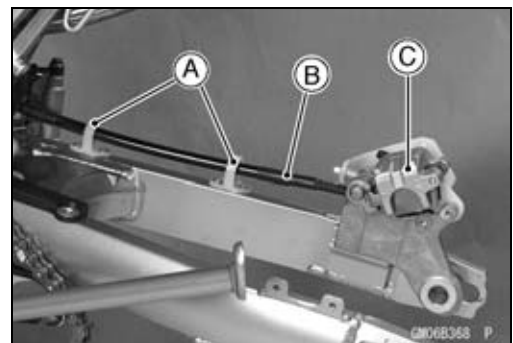

- Remove the air cleaner drain hose [A].
- Pull out the swingarm pivot shaft [B] to the left side, and remove the swingarm [C].

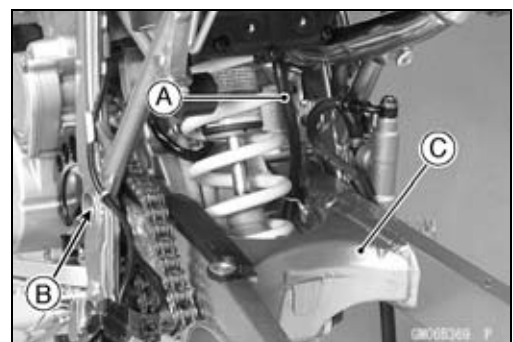

Swingarm

Swingarm Installation

- Install the grease seals [A] so that the hellow side [B] face the sleeve [C] in the swingarm pivot hole.
- Apply grease to the needle bearings [D] and outside of the sleeves.
- Replace the tie-rod nut with a new one.
- Tighten:

Torque - Swingarm Pivot Shaft Nut: 88 N·m (9.0 kgf·m, 65 ft·lb)

Tie-rod Nut (Rear): 83 N·m (8.5 kgf·m, 61 ft·lb)

- Install the removed parts (see appropriate chapters).

Swingarm Bearing Removal

- Remove:
 - Swingarm (see Swingarm Removal)
 - Grease Seals [A]
 - Sleeves [B]
- Remove the needle bearings [C] using the oil seal & bearing remover.

Special Tool - Oil Seal & Bearing Remover: 57001-1058

Swingarm Bearing Installation

- Replace the needle bearings [A] and grease seals [B] with new ones.
- Apply plenty of grease to the sleeves, grease seals, and needle bearings.

NOTE

○Install the needle bearings so that the manufacturer's marks face out.

Special Tool - Bearing Driver Set: 57001-1129

- Install the needle bearings and grease seals position as shown.
 - [C] 5 mm (0.2 in.)
- The installation procedure is the same as the counter side.

Needle Bearing, Sleeve Inspection

NOTICE

Do not remove the bearings for inspection. Removal may damage them.

- Inspect the needle bearings installed in the swingarm.
 - The needle bearing normally wear very little, and wear is difficult to measure. Instead of measuring, visually inspect the bearings for abrasion, discoloration, or other damage.
- ★If the needle bearing, and sleeve show any sings of abnormal wear, discoloration, or damage, replace them as a set.

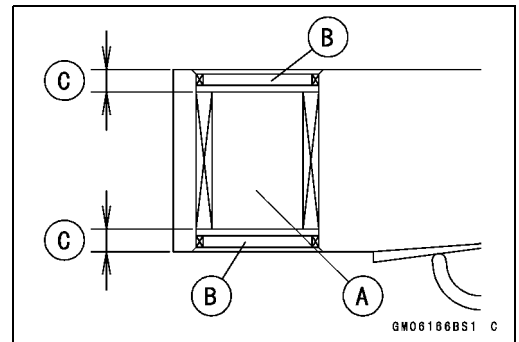
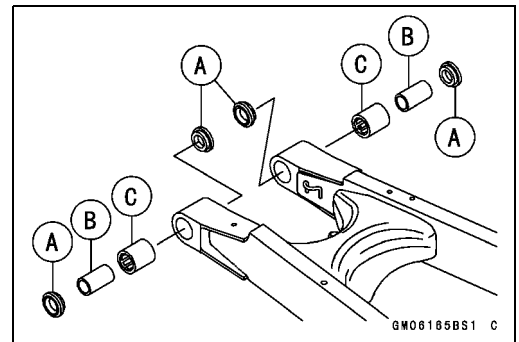
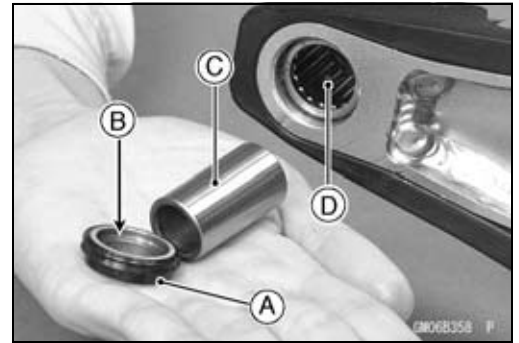

13-24 SUSPENSION

Tie-rod, Rocker Arm

Tie-rod Removal

- Using the jack, raise the rear wheel off the ground.
Special Tool - Jack: 57001-1238
- Remove:
 - Tie-rod Bolts [A] and Nuts
 - Tie-rod [B]

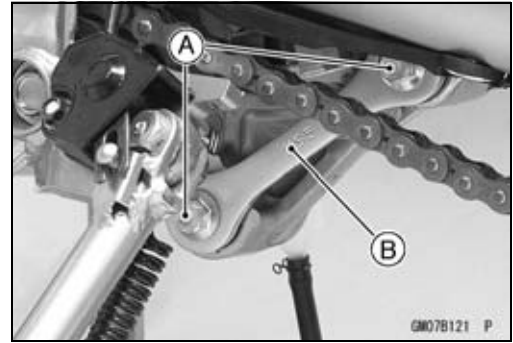

Tie-rod Installation

- Install the tie-rods so that the marked side [A] faces outside.
- Replace the tie-rod nuts with new ones.
- Tighten:
Torque - Tie-rod Nuts [B]: 83 N·m (8.5 kgf·m, 61 ft·lb)

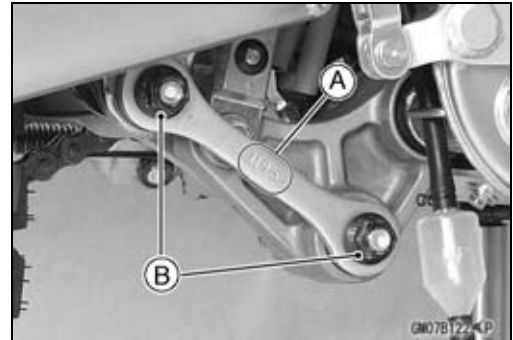

Rocker Arm Removal

- Using the jack, raise the rear wheel off the ground.
Special Tool - Jack: 57001-1238
- Remove:
 - Tie-rod Bolt and Nut (Front) [A]
 - Rocker Arm Pivot Shaft Nut [B]
 - Lower Rear Shock Absorber Bolt [C]

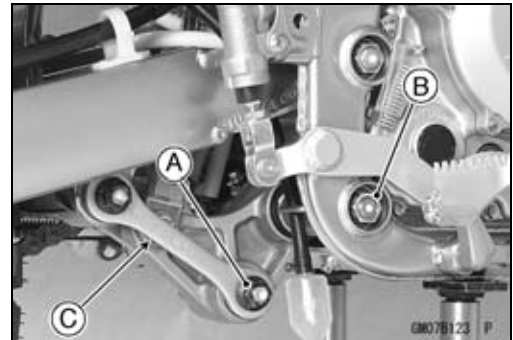

- Pull out the rocker arm pivot shaft [A].
- When the rocker arm pivot shaft does not remove, loosen the swingarm pivot shaft.
- Remove the rocker arm [B].



Rocker Arm Installation

- Apply plenty of grease to the inside of the rocker arm hole, outside of the sleeve and needle bearings.
- Replace the tie-rod nut with a new one.
- Tighten:
Torque - Rocker Arm Pivot Shaft Nut: 98 N·m (10 kgf·m, 72 ft·lb)
Lower Rear Shock Absorber Bolt: 39 N·m (4.0 kgf·m, 29 ft·lb)
Tie-rod Nut: 83 N·m (8.5 kgf·m, 61 ft·lb)

Tie-rod, Rocker Arm

Tie-Rod and Rocker Arm Bearing Removal

- Remove:
 - Tie-Rods (see Tie-Rod Removal)
 - Rocker Arm (see Rocker Arm Removal)
 - Swingarm (See Swingarm Removal)
 - Sleeves [A]
 - Grease Seals [B]
 - Needle Bearings [C]

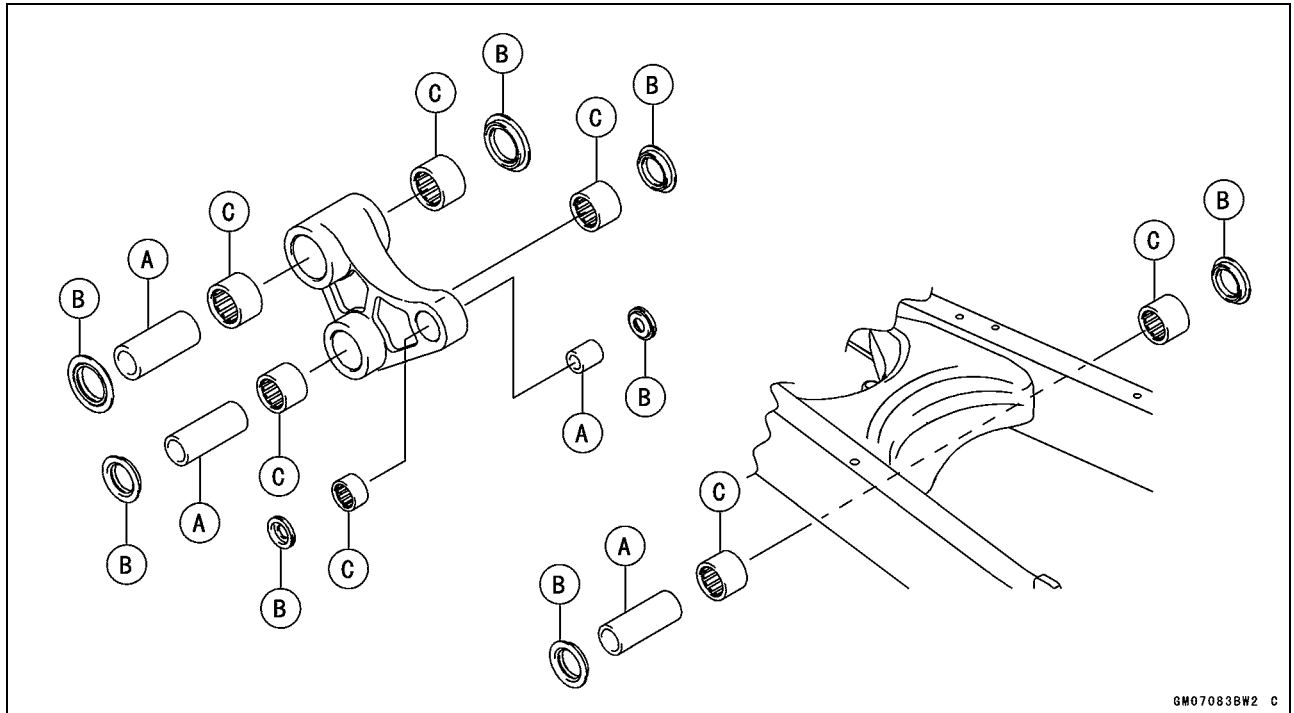

GM07083BW2 C

- Remove the rocker arm pivot and tie-rod needle bearings, using the oil seal & bearing remover [A].
 - Special Tool - Oil Seal & Bearing Remover: 57001-1058**
- Remove the lower rear shockabsorber needle bearing, using the available remover.

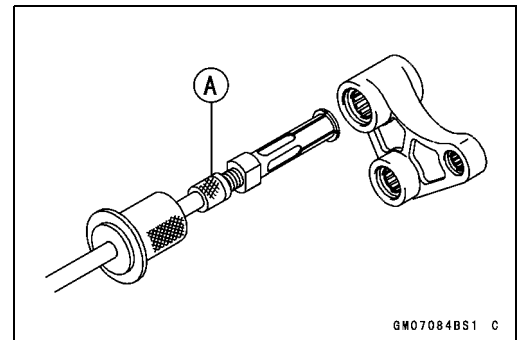

GM07084BS1 C

13-26 SUSPENSION

Tie-rod, Rocker Arm

Tie-Rod and Rocker Arm Bearing Installation

- Replace the needle bearings with new ones.
 - Apply plenty of grease to the new needle bearings.
 - Install the needle bearings so that the manufacturer's marks faces out.
 - Install the new needle bearings [A] and grease seals [B] position as shown
 - 5.0 mm (0.20 in.) [C]
 - 4.0 mm (0.22 in.) [D]
 - Rear Shock Absorber [E]
 - Tie-Rods [F]
 - Rocker Arm [G]
 - Front [H]
 - Right Side [I]
 - Left Side [J]
- Using a suitable bearing driver and the bearing driver set (special tool: 57001-1129).

Special Tool - Bearing Driver Set: 57001-1129

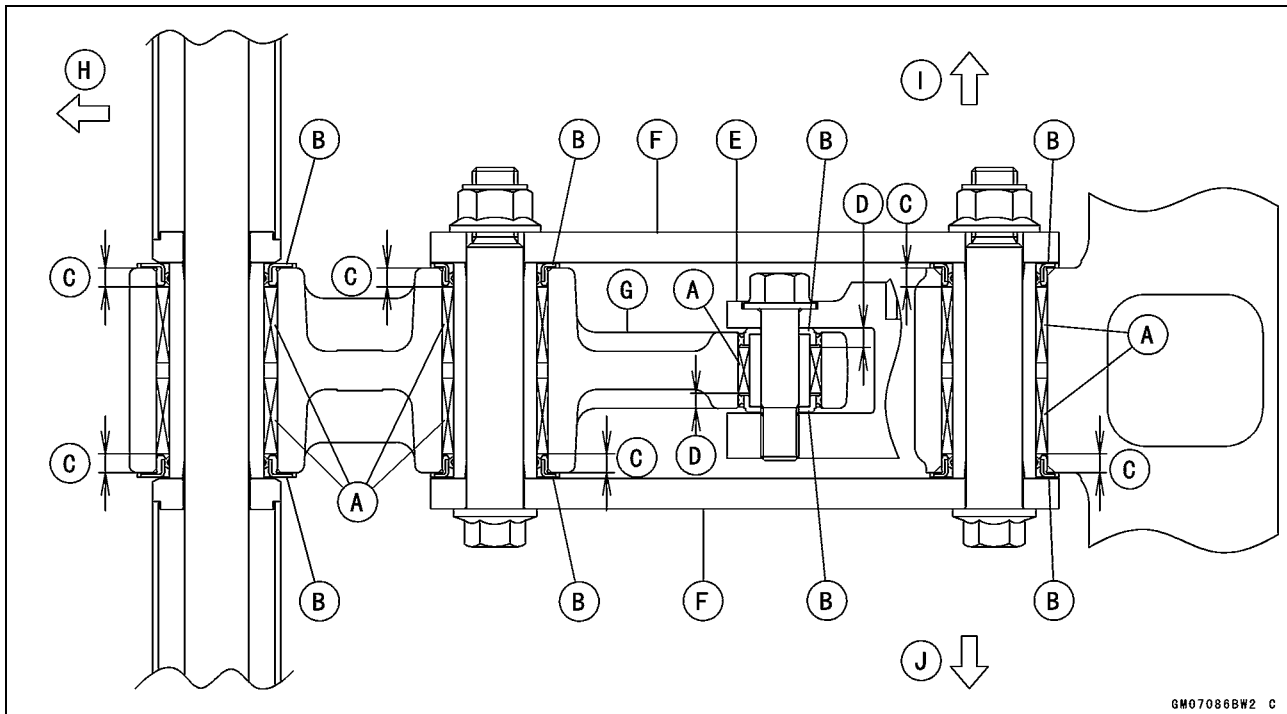

Rocker Arm Sleeve Inspection

- Removal the rocker arm (see Rocker Arm Removal)
- Take out the sleeves [A] from the rocker arm and measure its outer diameter.

Sleeve Outside Diameter

Standard: 24.987 ~ 25.000 mm (0.98373 ~ 0.98425 in.)

21.987 ~ 22.000 mm (0.86563 ~ 0.86614 in.)

15.989 ~ 16.000 mm (0.62949 ~ 0.62992 in.)

Service Limit: 24.85 mm (0.9783 in.)

21.85 mm (0.8602 in.)

15.85 mm (0.6240 in.)

- ★ If the sleeve is worn down to less than the service limit, replace it.

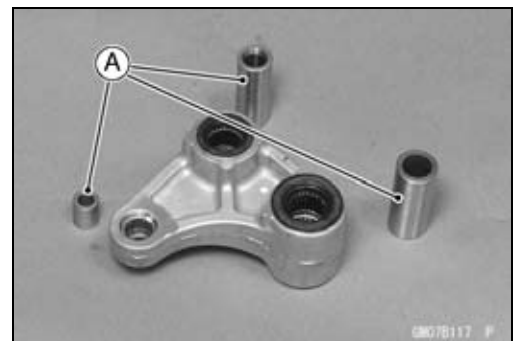

Tie-rod, Rocker Arm

Needle Bearing, Sleeve Inspection

NOTICE

Do not remove the bearings for inspection. Removal may damage them.

- Inspect the needle bearings installed in the rocker arm.
- The needle bearing normally wear very little, and wear is difficult to measure. Instead of measuring, visually inspect the bearings for abrasion, discoloration, or other damage.
- ★ If the needle bearing, and sleeve show any signs of abnormal wear, discoloration, or damage, replace them as a set.

Rocker Arm Pivot Shaft Bent Inspection

A bent shaft causes vibration, poor handling, and instability.

- To measure the bolt runout, remove the bolt, place it in V blocks, and set a dial gauge to the bolt at a point halfway between the blocks. Turn [A] the bolt to measure the runout. The amount of dial variation is the amount of runout.

Rocker Arm Pivot Shaft Runout

Standard: TIR 0.1 mm (0.004 in.) or less

Service Limit: TIR 0.2 mm (0.008 in.)

- ★ If any measurement exceeds the service limit, replace the shaft.

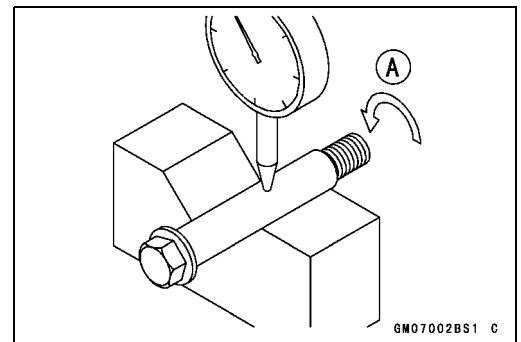

Steering

Table of Contents

Exploded View	14-2
Special Tools	14-4
Steering	14-5
Steering Inspection	14-5
Steering Adjustment.....	14-5
Steering Stem.....	14-6
Steering Stem, Stem Bearing Removal	14-6
Steering Stem, Stem Bearing Installation	14-8
Stem Bearing Lubrication.....	14-9
Steering Stem Warp.....	14-10
Stem Cap Deterioration, Damage.....	14-10
Handlebar	14-11
Handlebar Removal	14-11
Handlebar Installation	14-11

14-2 STEERING

Exploded View

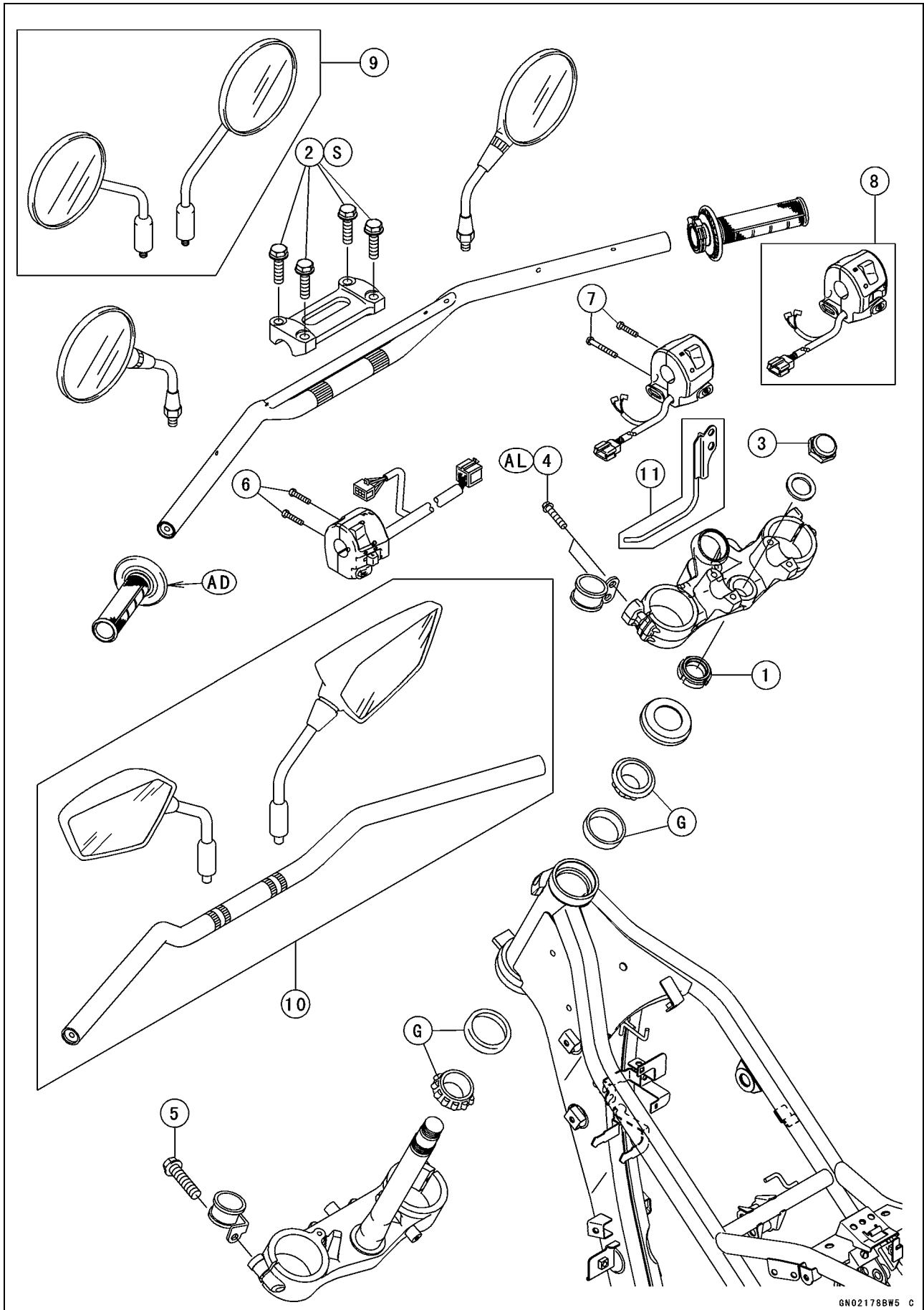

Exploded View

No.	Fastener	Torque			Remarks
		N·m	kgf·m	ft·lb	
1	Steering Stem Nut	4.9	0.50	43 in·lb	
2	Handlebar Clamp Bolts	25	2.5	18	S
3	Steering Stem Head Nut	44	4.5	32	
4	Upper Front Fork Clamp Bolts	20	2.0	15	AL
5	Lower Front Fork Clamp Bolts	25	2.5	18	
6	Left Switch Housing Screws	3.5	0.36	31 in·lb	
7	Right Switch Housing Screws	3.5	0.36	31 in·lb	

8. IN Model

9. EUR Model

10. KLX250V Model

11. KLX250S9F (TH)/V9F (TH)

AD: Apply adhesive.

AL: Tighten the clamp bolts alternately two times to ensure even tightening torque.

G: Apply grease.

S: Following the specified tightening sequence.

14-4 STEERING

Special Tools

Bearing Puller:
57001-135

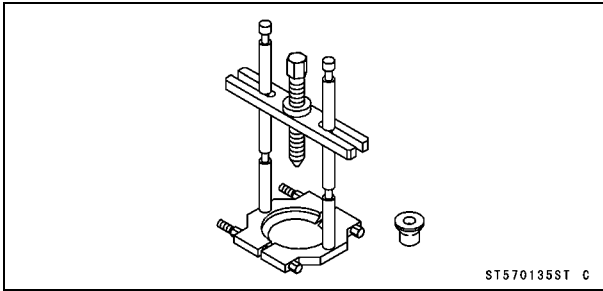

Steering Stem Bearing Driver:
57001-137

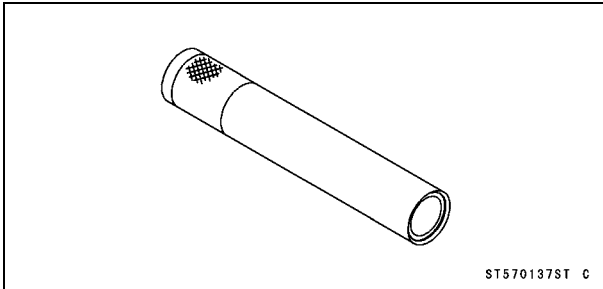

Steering Stem Bearing Driver Adapter, $\phi 34.5$:
57001-1074

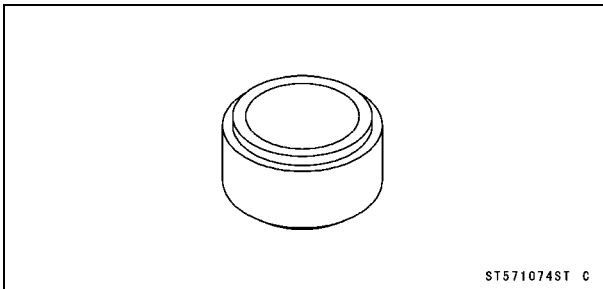

Head Pipe Outer Race Press Shaft:
57001-1075

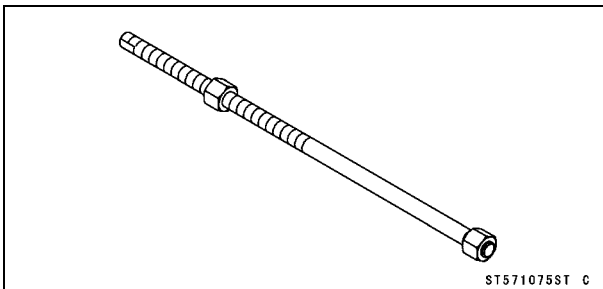

Head Pipe Outer Race Driver, $\phi 54.5$:
57001-1077

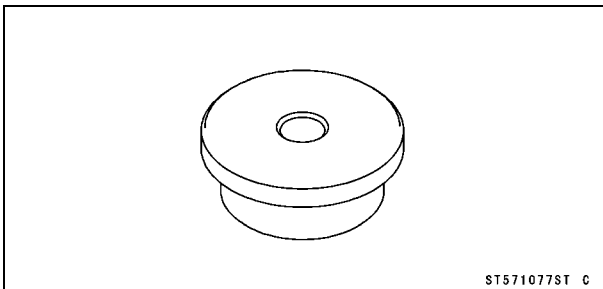

Steering Stem Nut Wrench:
57001-1100

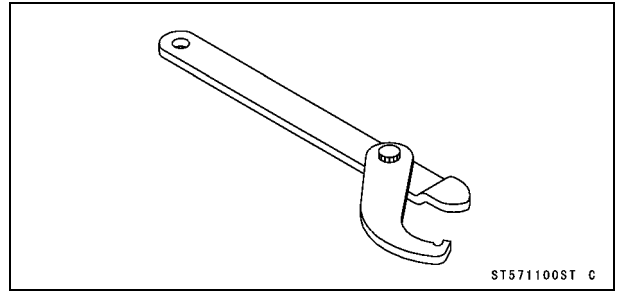

Head Pipe Outer Race Driver, $\phi 46.5$:
57001-1106

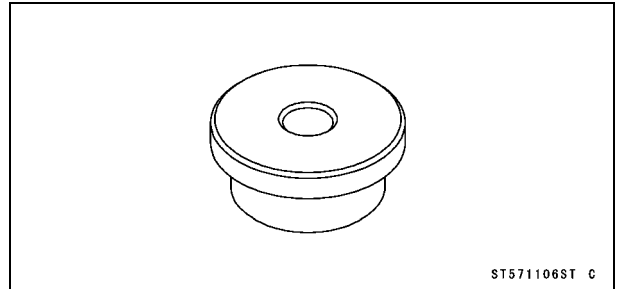

Head Pipe Outer Race Remover ID > 37 mm:
57001-1107

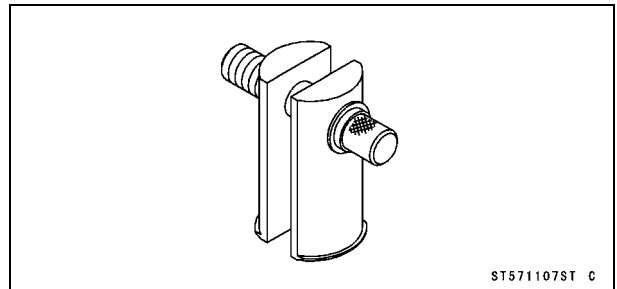

Bearing Puller:
57001-1575

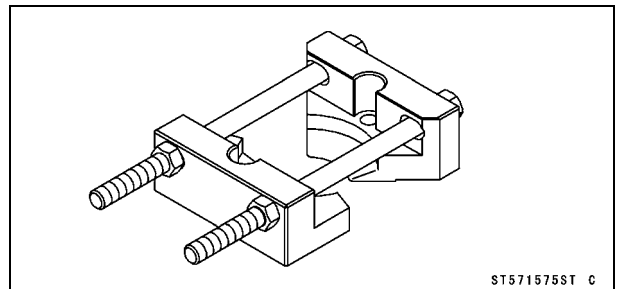

Steering

Steering Inspection

- Refer to the Steering Play Inspection in the Periodic Maintenance chapter.

Steering Adjustment

- Refer to the Steering Play Adjustment in the Periodic Maintenance chapter.

14-6 STEERING

Steering Stem

Steering Stem, Stem Bearing Removal

- Disconnect the starter lockout switch connector [A].
- Open the clamp [B].
- Remove the left switch housing [C] from the handlebar.
- Remove the clutch cable upper end [D] from the clutch lever.

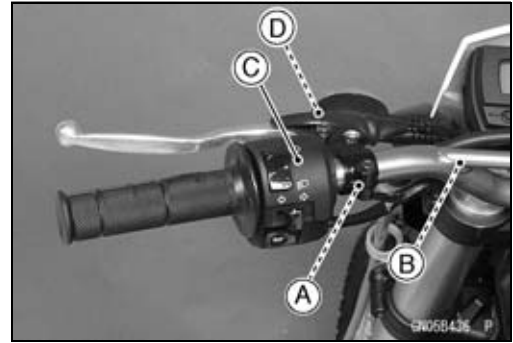

- Disconnect the brake light switch connectors [A].
- Open the clamp [B].
- Remove the right switch housing [C] from the handlebar.
- Remove the throttle cable upper ends [D] from the throttle grip [E].

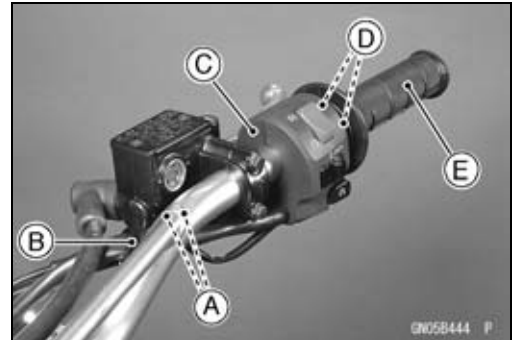

- Remove:
 - Meter Unit (see Meter Unit Removal in the Electrical System chapter)
 - Speed Sensor Connector [A]
 - Ignition Switch Connector [B]
 - Turn Signal Light Connectors [C]
 - Bolts [D]
 - Bracket (both turn signal light installed) [E]

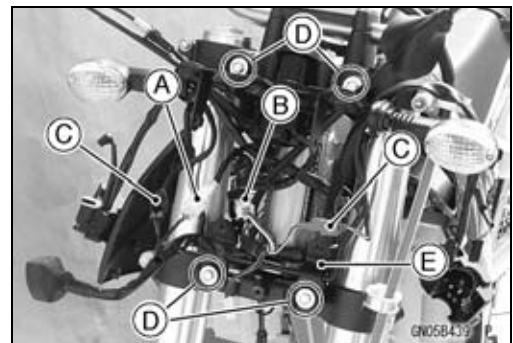

- Remove:
 - Brake Hose Holder Bolt [A]
 - Front Caliper Mounting Bolts [B]
- Remove the front caliper [C] from the front fork.
- Remove the left front fork protector bolts [D].
- Remove the handlebar clamp (see Handlebar Removal).

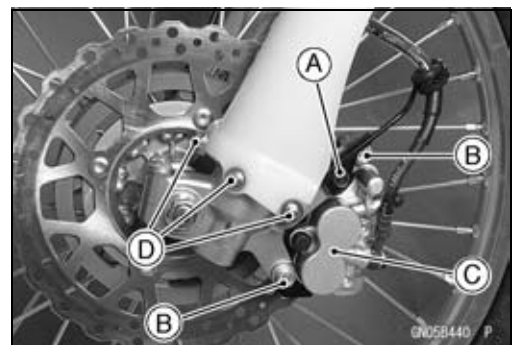

- Remove:
 - Right Front Fork Protector Bolts [A].



Steering Stem

- Remove:
 - Speed Sensor Lead Clamp Bolt [A]
 - Front Wheel (see Front Wheel Removal in the Wheels/Tires chapter)
- Remove the right fork protector with the speed sensor.



- Remove:
 - Steering Stem Head Nut [A] and Washer
 - Upper Front Fork Clamp Bolts [B]
 - Steering Stem Head [C]
 - Lower Front Fork Clamp Bolts [D]
- Remove the following parts as a set.
 - Handlebar
 - Front Master Cylinder
 - Clutch Lever
 - Brake Hose
 - Front Brake Caliper
 - Left Front Fork Protector
- Pull out the front fork [E].

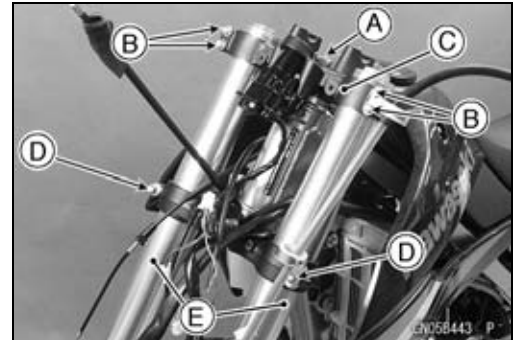

- Pushing up the stem base, and remove the steering stem nut [A] and stem cap [B].
 - Special Tool - Steering Stem Nut Wrench [C]: 57001-1100**
- Remove the steering stem [D].

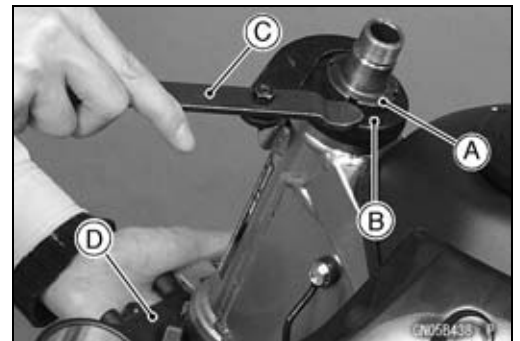

- Remove the upper stem bearing inner race (tapered roller) [A].

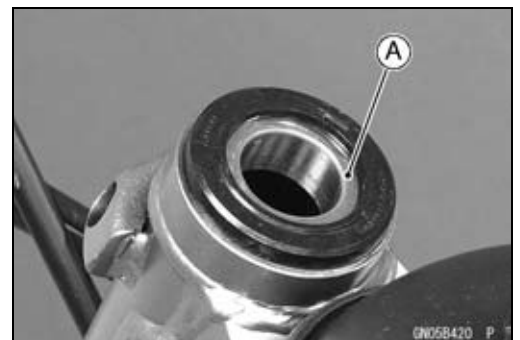

14-8 STEERING

Steering Stem

- Drive out the bearing outer races from the head pipe.
- Remove the outer races pressed into the head pipe, using the head pipe outer race remover [A], and hammer the head pipe outer race remover to drive it out.

Special Tool - Head Pipe Outer Race Remover ID>37 mm: 57001-1107

NOTE

○ If either steering stem bearing is damaged, it is recommended that both the upper and lower bearing (including outer races) should be replaced with new ones.

- Remove the lower stem bearing inner race (tapered roller bearing) with its grease seal from the stem using bearing pullers.

Special Tools - Bearing Puller: 57001-135
Bearing Puller: 57001-1575

- Assemble the bearing puller (57001-1575).
- Insert the each half-split base [A] under the bottom of bearing inner race and connect the both bases by tightening the bolts [B] and nuts [C].
- Assemble the parts of the bearing puller (57001-135) as shown in the figure.
 - Stud Bolts [D]
 - Arm [E]
 - Center Bolt [F]
 - Adapter [G]
- Turn the center bolt by a wrench and pull the bearing inner race.

NOTE

○ Tighten evenly two bases by the two bolts.

Steering Stem, Stem Bearing Installation

- Replace the bearing outer race with new ones.
- Apply grease to the outer races, and drive them into the head pipe at the same time using the head pipe outer race press shaft [A] and the drivers.

Special Tools - Head Pipe Outer Race Press Shaft: 57001-1075
Head Pipe Outer Race Driver, ϕ 54.5: 57001-1077 [B]
Head Pipe Outer Race Driver, ϕ 46.5: 57001-1106 [C]

- Replace the lower inner races with new ones.
- Apply grease to the lower tapered roller bearing [A], and drive it onto the stem using the steering stem bearing driver [C] and adapter [B].

Special Tools - Steering Stem Bearing Driver: 57001-137
Steering Stem Bearing Driver Adapter, ϕ 34.5: 57001-1074

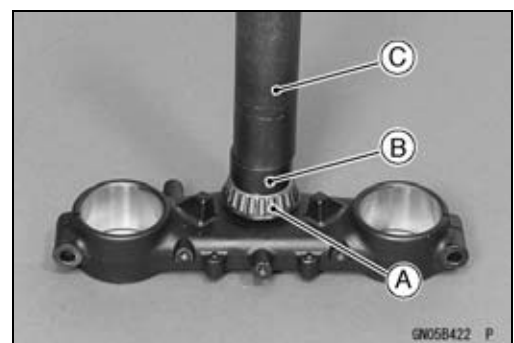
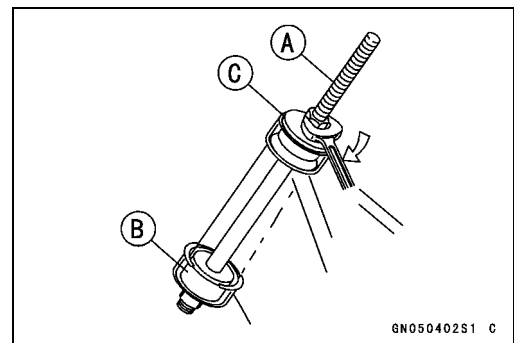
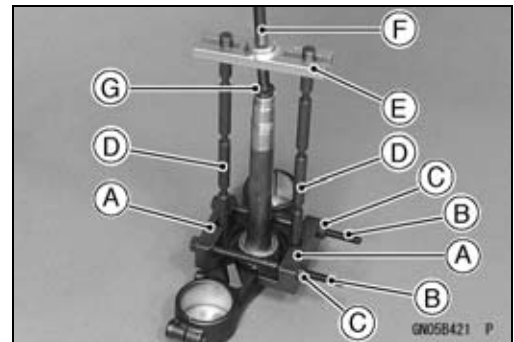
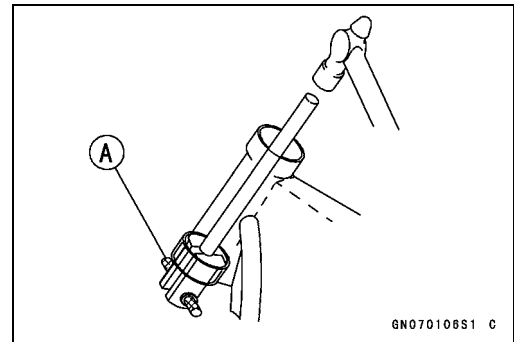

Steering Stem

- Apply grease to the upper inner race, and install it in the head pipe.
- Install the stem through the head pipe and upper bearing, and hand-tighten the nut while pushing up on the stem base.
- Install the stem head and washer, and tighten the stem head nut lightly.
- Settle the bearing in place as follows;
 - Tighten the stem nut to **39 N·m (4.0 kgf·m, 29 ft·lb)** of torque. (To tighten the steering stem nut to the specified torque, hook the wrench [A] on the stem nut, and pull the wrench at the hole by **22.2 kg** force [B] in the direction shown.)

Special Tool - Steering Stem Nut Wrench: 57001-1100

- Check that there is no play and the steering stem turns smoothly without rattles. If not, the steering stem bearings may be damaged.
- Again back out the stem nut a fraction of a turn until it turns lightly.
- Turn the stem nut lightly clockwise until it just becomes hard to turn. Do not overtighten, or the steering will be too tight.

Torque - Steering Stem Nut: 4.9 N·m (0.50 kgf·m, 43 in·lb)

- Install the stem head.
- Install the washer [A] as shown.
- Tighten the stem head nut [B] temporary.
- Install the front forks (see Front Fork Installation in the Suspension chapter).

NOTE

- Tighten the upper fork clamp bolts first, next the stem head nut, last the lower fork clamp bolts.
- Tighten the two upper fork clamp bolts alternately two times to ensure even tightening torque.

Torque - Upper Front Fork Clamp Bolts: 20 N·m (2.0 kgf·m, 15 ft·lb)

Steering Stem Head Nut: 44 N·m (4.5 kgf·m, 32 ft·lb)

Lower Front Fork Clamp Bolts: 25 N·m (2.5 kgf·m, 18 ft·lb)

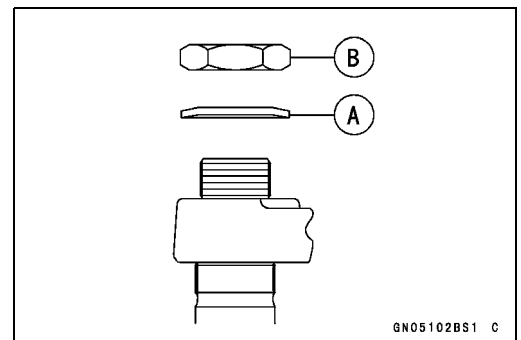
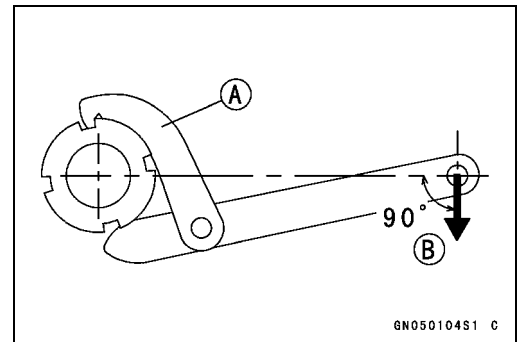

⚠ WARNING

If the handlebar does not turn to the steering stop it may cause an accident resulting in injury or death. Be sure the cables, harnesses and hoses are routed properly and do not interfere with handlebar movement (see Cable, Wire, and Hose Routing section in the Appendix chapter).

- Install the removed parts (see appropriate chapters).

Stem Bearing Lubrication

- Refer to the Steering Stem Bearing Lubrication in the Periodic Maintenance chapter.

14-10 STEERING

Steering Stem

Steering Stem Warp

- Whenever the steering stem is removed, or if the steering cannot be adjusted for smooth action, check the steering stem for straightness.
- ★ If the steering stem [A] is bent, replace the steering stem.

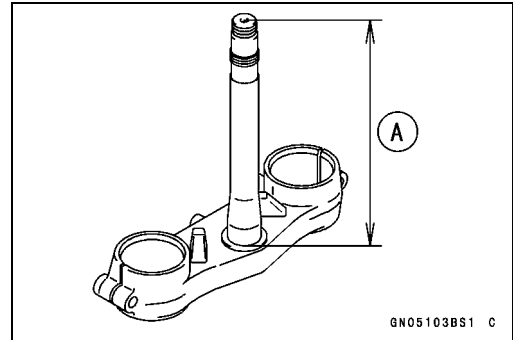

Stem Cap Deterioration, Damage

- ★ Replace the stem cap if its oil seal [A] shows damage.



Handlebar

Handlebar Removal

- Remove:
 - Left Handlebar Grip [A]
 - Clutch Cable Upper End [B] (see Clutch Cable Removal in the Clutch chapter)
 - Left Switch Housing [C]
 - Clutch Lever Assembly [D]
 - Clamp [E]

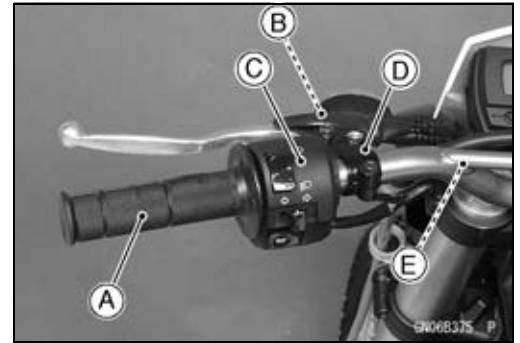

- Remove:
 - Front Brake Master Cylinder [A] (see Front Master Cylinder Removal in the Brakes chapter)
 - Right Switch Housing [B]
 - Throttle Cable Upper Ends [C] (see Throttle Cable Removal in the Fuel System (DFI) chapter)
 - Throttle Grip [D]
 - Clamp [E]

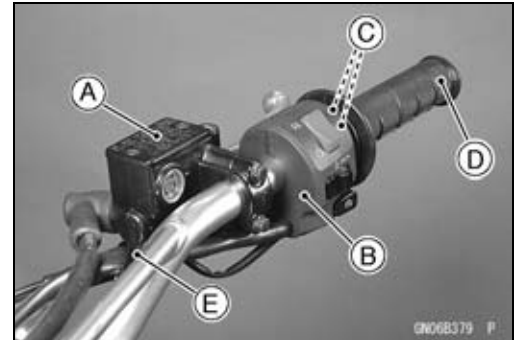

- Remove:
 - Handlebar Clamp Bolts [A]
 - Handlebar Clamp [B]
 - Handlebar [C]

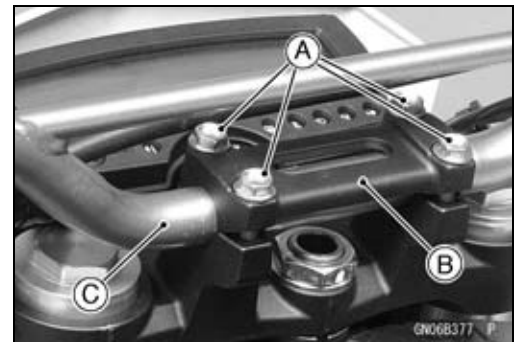

Handlebar Installation

- Install the handlebar clamp [A] so that the notch side [B] faces backward.
- Align the punch mark [C] on the handlebar and corner edge [D] on the stem head.

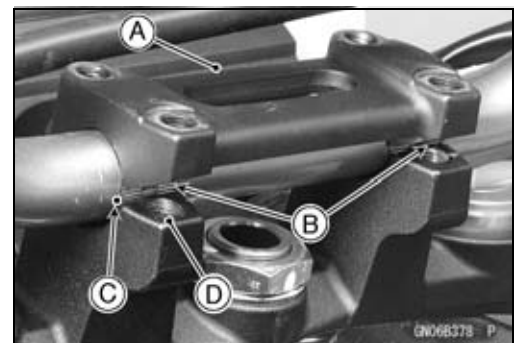

- Tighten the front clamp bolts [A] first, and then the rear clamp bolts [B].
- There will be a gap [C] at the rear part of the handlebar clamp after tightening.

Torque - Handlebar Clamp Bolts: 25 N·m (2.5 kgf·m, 18 ft·lb)

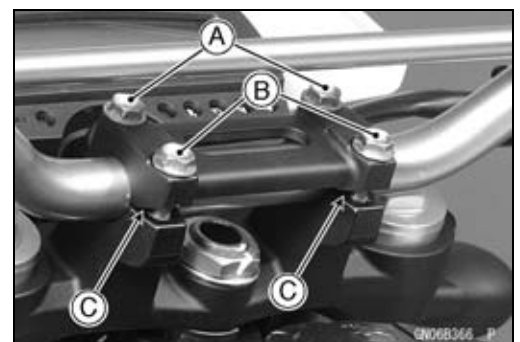

14-12 STEERING

Handlebar

- Install the clutch lever (see Clutch Lever Installation in the Clutch chapter).
- Apply adhesive to the inside of the left handlebar grip.
- Install the left handlebar grip until its end hit the handlebar end and up mark [A] faces upward.

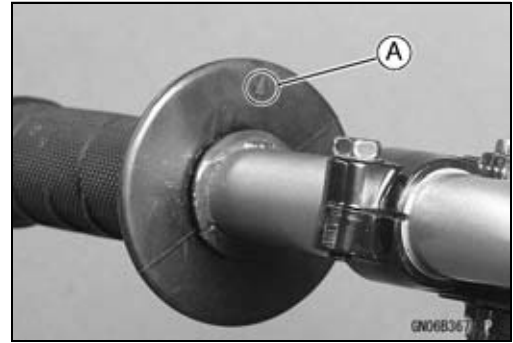

- Install the left switch housing.
 - Fit the spacer [A] into the groove on the front half of the left switch housing.
 - Run the left and right switch housing lead into the clamp of the handlebar correctly (see Cable, Wire, and Hose Routing section in the Appendix chapter).
 - Fit the projection [B] into a small hole [C] in the handlebar.

Torque - Left Switch Housing Screws: 3.5 N·m (0.36 kgf·m, 31 in·lb)

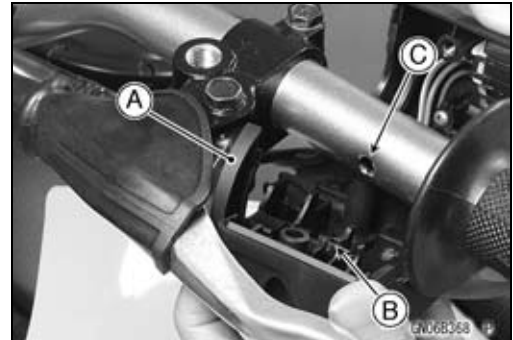

- Install:
 - Throttle Grip [A]
 - Throttle Cable Tips [B]
 - Right Switch Housing
- Fit the projection [C] into a small hole [D] in the handlebar.

Torque - Right Switch Housing Screws: 3.5 N·m (0.36 kgf·m, 31 in·lb)

- Install the front brake master cylinder (see Front Master Cylinder Installation in the Brakes chapter).

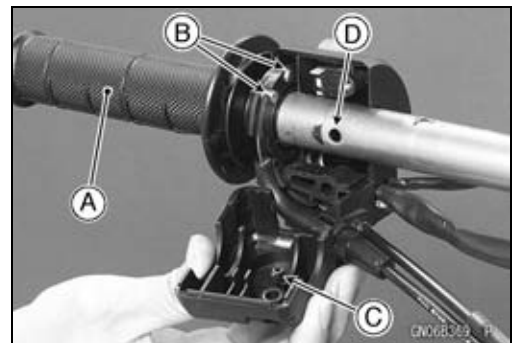

Frame

Table of Contents

Exploded View	15-2
Special Tool	15-5
Seat	15-6
Seat Removal	15-6
Seat Installation	15-6
Side Cover	15-7
Side Cover Removal	15-7
Side Cover Installation	15-7
Radiator Shroud	15-8
Radiator Shroud Removal.....	15-8
Radiator Shroud Installation.....	15-8
Fender	15-9
Front Fender Removal	15-9
Front Fender Installation	15-9
Rear Fender Front Removal	15-9
Rear Fender Front Installation	15-9
Rear Fender Flap Front Removal	15-10
Rear Fender Rear Removal.....	15-10
Rear Fender Rear Installation.....	15-10
Rear Fender Flap Rear Removal.....	15-11
Battery Case	15-12
Battery Case Removal	15-12
Battery Case Installation	15-12
Tool Kit Bag	15-13
Tool Kit Bag Removal.....	15-13
Tool Kit Bag Installation.....	15-13
Sidestand.....	15-14
Sidestand Removal.....	15-14
Sidestand Installation.....	15-14
Frame	15-16
Frame Inspection	15-16

15-2 FRAME

Exploded View

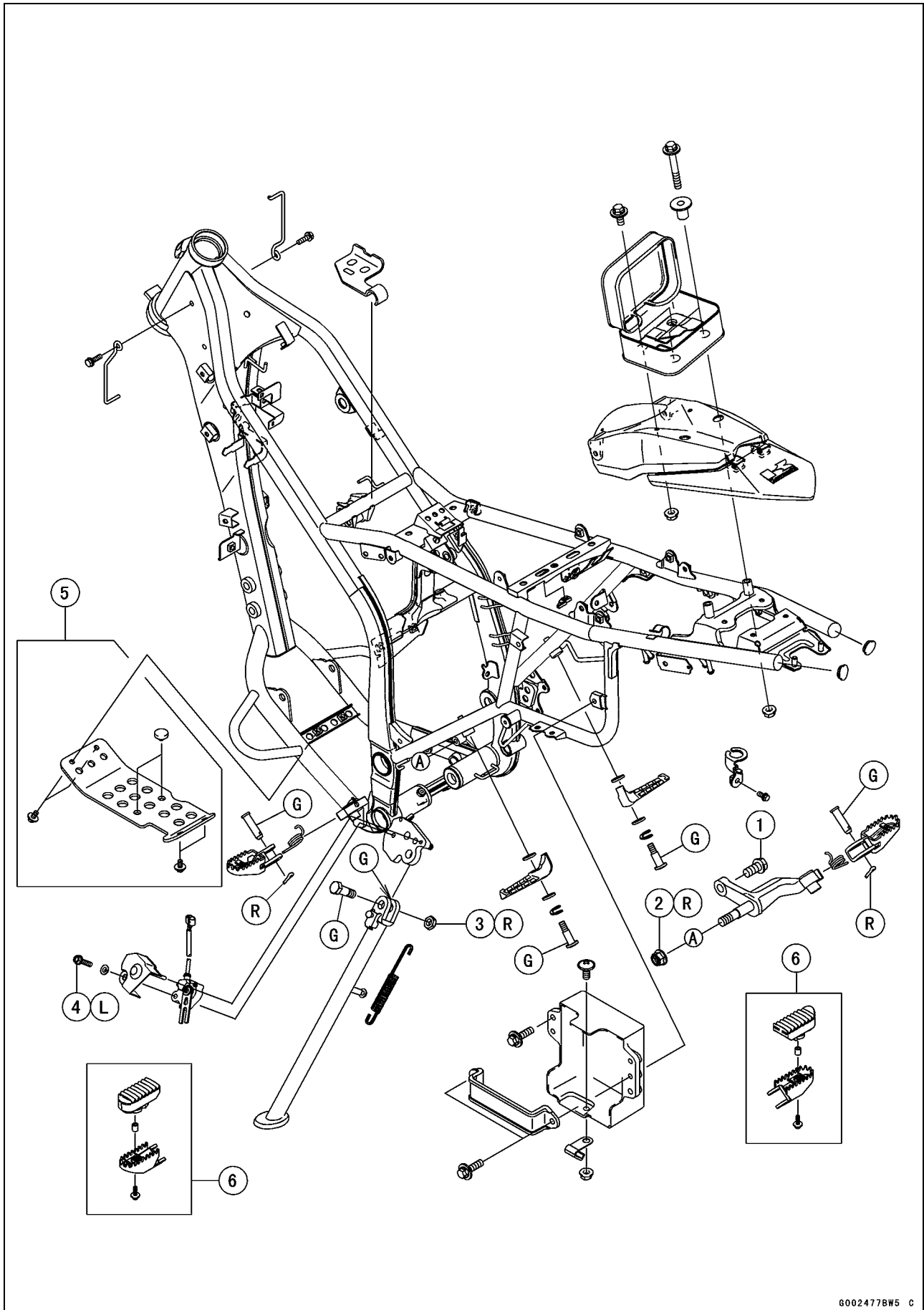

Exploded View

No.	Fastener	Torque			Remarks
		N·m	kgf·m	ft·lb	
1	Front Footpeg Bracket Bolt	39	4.0	29	
2	Front Footpeg Bracket Nut	39	4.0	29	R
3	Sidestand Nut	44	4.5	32	R
4	Sidestand Switch Mounting Bolt	8.8	0.90	78 in·lb	L

5. KLX250S Model

6. KLX250V and EUR Models

G: Apply grease.

L: Apply a non-permanent locking agent.

R: Replacement Parts

15-4 FRAME

Exploded View

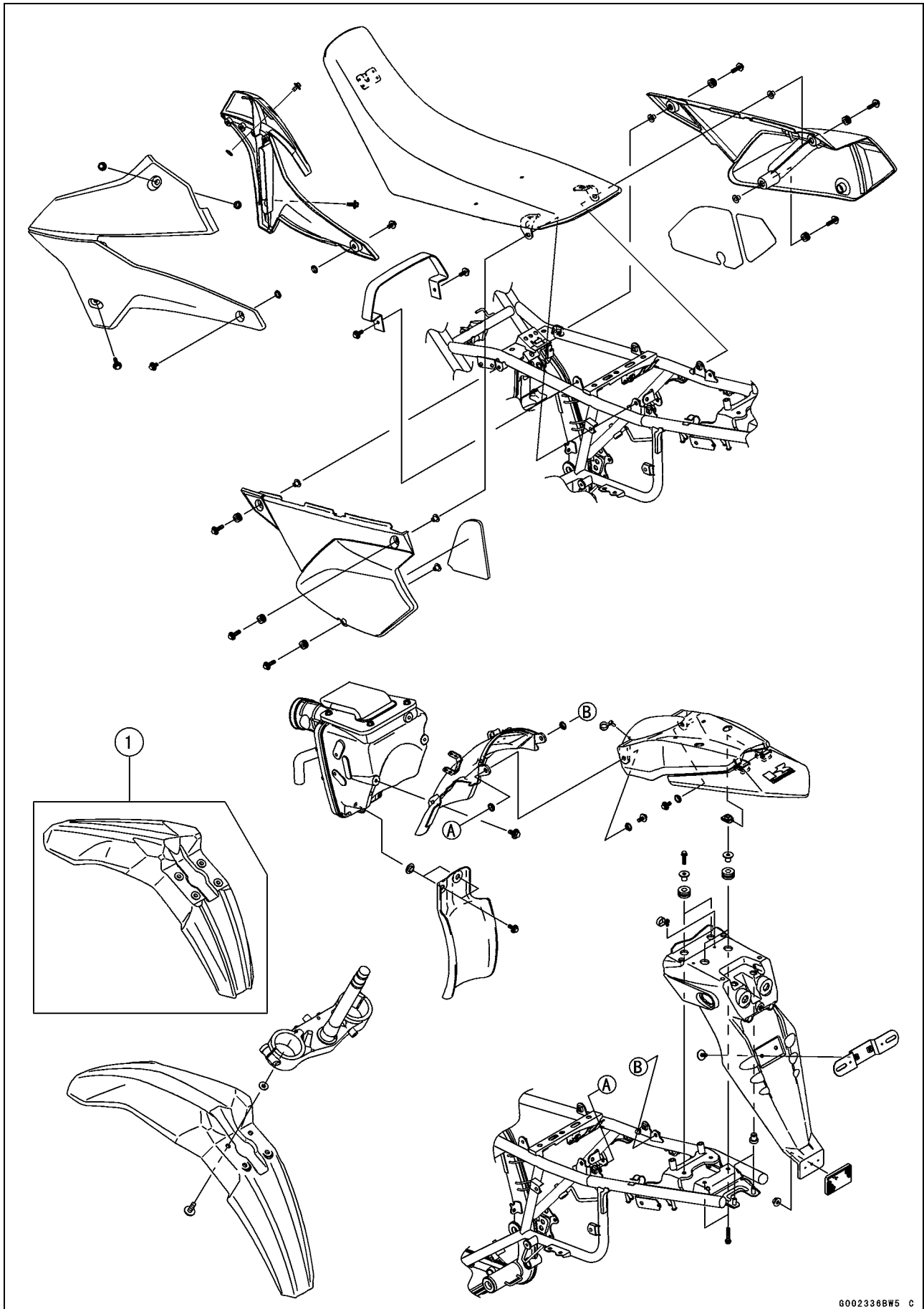

G002336W5 C

1. KLX250V Model

Special Tool

Jack:
57001-1238

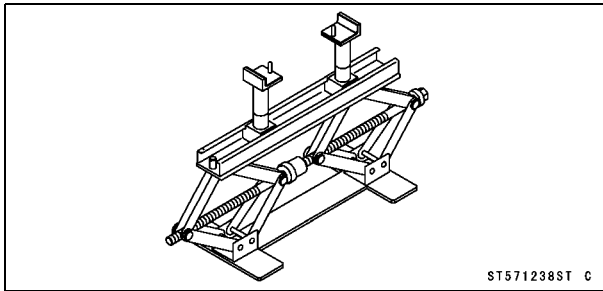

15-6 FRAME

Seat

Seat Removal

- Remove:
 - Left and Right Side Covers (see Side Cover Removal)
 - Bolts [A]
 - Tandem Belt [B]
- Pull the seat [C] backward to remove the seat.

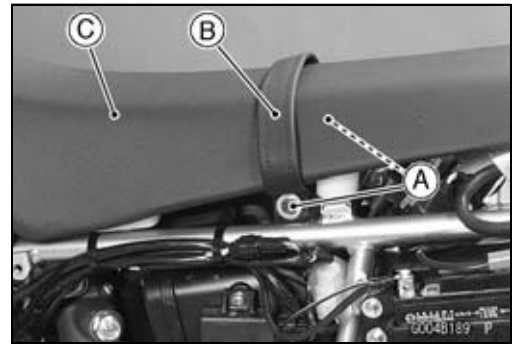

Seat Installation

- Insert the seat hooks [A] into the stoppers [B] of the fuel tank and the frame.

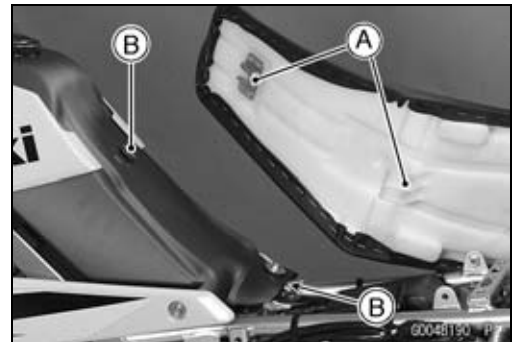

Side Cover

Side Cover Removal

- Remove:
 - Bolts [A]
 - Side Cover [B]

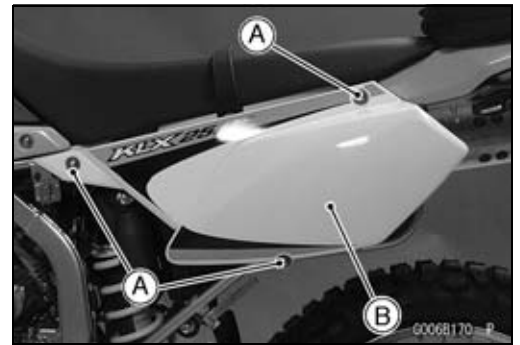

Side Cover Installation

- Fit the notch [A] of the side cover to the tandem belt [B] lower side, and tighten the mounting bolts.

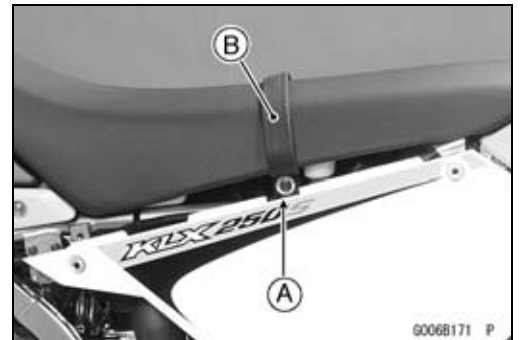

15-8 FRAME

Radiator Shroud

Radiator Shroud Removal

- Remove:
 - Bolts [A]
 - Radiator Shroud [B]



Radiator Shroud Installation

- Install:
 - Radiator Shroud [A]
 - Bolts (L = 12) [B]
 - Bolt (L = 20) [C]



Fender

Front Fender Removal

- Remove:
 - Bolts [A]
 - Front Fender [B]



Front Fender Installation

- Installation is the reverse of removal.
- Be sure to install the collars [A] to the front fender.

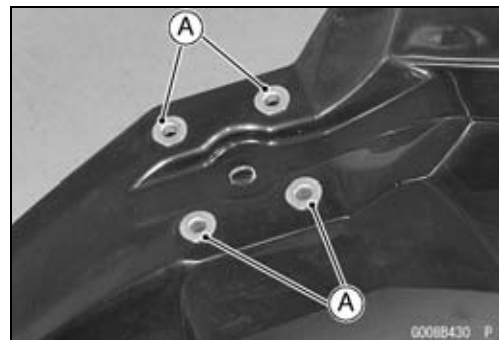

Rear Fender Front Removal

- Remove:
 - Rear Fender Rear (see Rear Fender Rear Removal)
 - Muffler Body Cover (see Muffler Body Removal in the Engine Top End chapter)
 - Bolts [A]
- While bending the rear fender front, push down it.

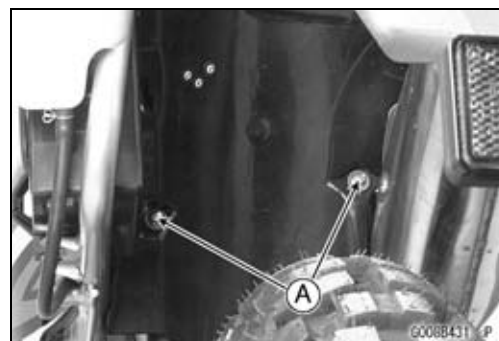

- Remove:
 - Starter Relay [A] (see Starter Relay Removal in the Electrical System chapter)
 - Oxygen Sensor Connector (disconnect) [B]
 - Interlock Diode Unit [C]
 - Starter Circuit Relay [D]

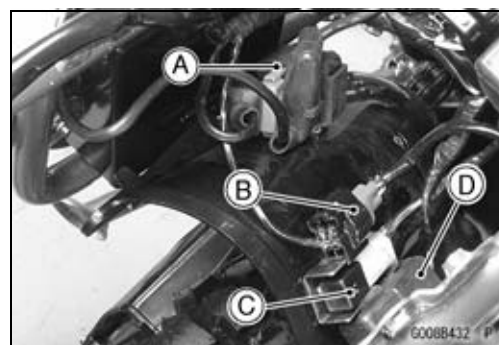

Rear Fender Front Installation

- Installation is reverse of removal.

15-10 FRAME

Fender

Rear Fender Flap Front Removal

- Remove:
 - Bolts [A]
- Remove the rear fender flap front [B] from the air cleaner housing.



Rear Fender Rear Removal

- Remove:
 - Seat (see Seat Removal)
 - Tool Kit Bag (see Tool Kit Bag Removal)
- Open the clamp [A].



- Remove:
 - Bolts [A]



- Remove:
 - Bolts [A]
 - Rear Fender Rear [B]

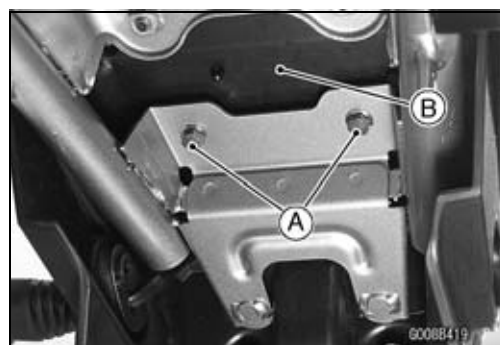

Rear Fender Rear Installation

- Installation is the reverse of removal.
- Install the clamp [B] to hold the tail/rear brake light lead [A].

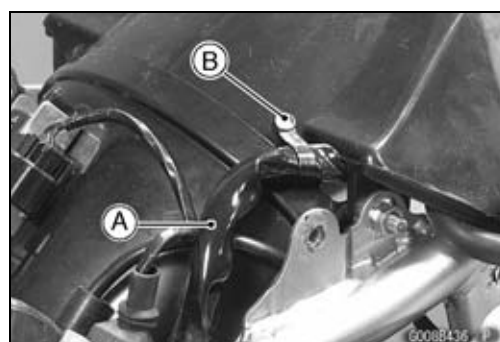

Fender

Rear Fender Flap Rear Removal

- Remove:
 - Rear Fender Rear (see Rear Fender Rear Removal)
 - Clamp [A]
- Disconnect:
 - Tail/Brake Light Connector [B]
 - Turn Signal Light Connectors [C]
- Remove the mounting bolts [D], then remove the rear fender flap rear together with the tail/brake light and turn signal lights installed.

- Remove:
 - Clamp [A]

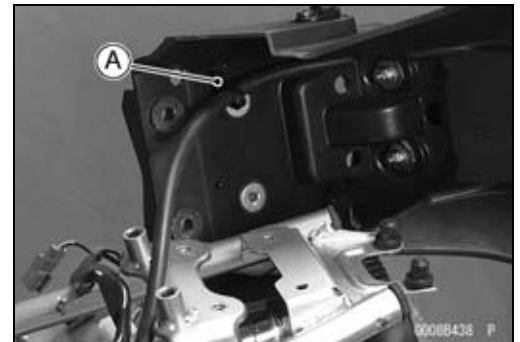
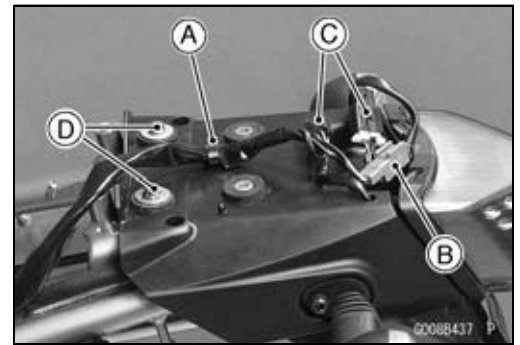

15-12 FRAME

Battery Case

Battery Case Removal

- Remove:
 - Battery (see Battery Removal in the Electrical System chapter)
 - Bolts [A]
 - Reserve Tank [B]

NOTICE

Make sure that the reserve tank will not be put upside down, or the coolant may leak from the overflow hose.

- Remove:
 - Bolt [A]
 - Screw [B]
 - Nut [C]
 - Battery Case [D]

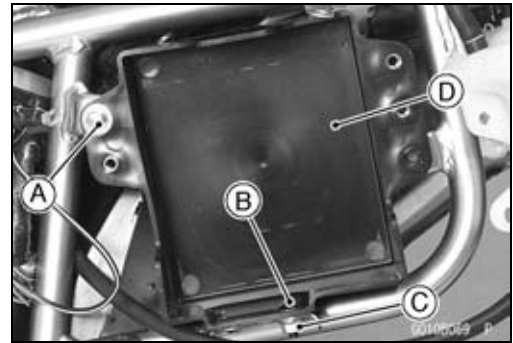
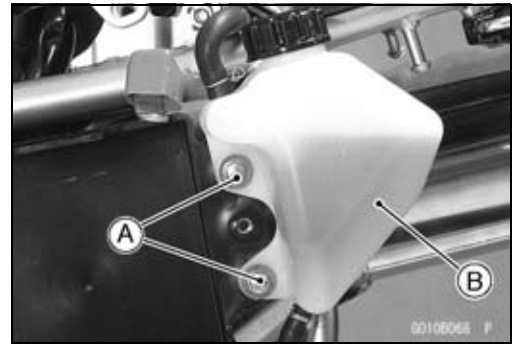

Battery Case Installation

- Install the battery case so that the projection [A] of the battery case bottom fit hole [B] of the frame.

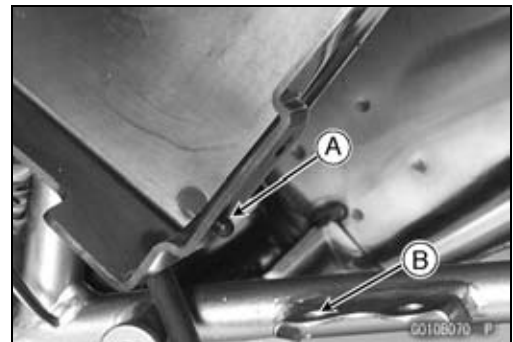

Tool Kit Bag

Tool Kit Bag Removal

NOTE

○ Before washing the motorcycle, empty the tool kit bag.

- Remove:
Bolts [A], Nuts and Collars
Tool Kit Bag [B]

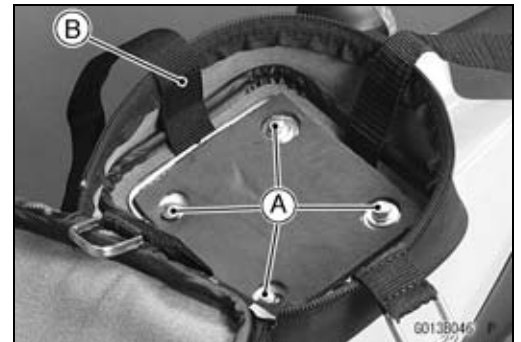

Tool Kit Bag Installation

- Insert the collar [A] into the larger hole.
- Install the tool kit bag on the rear fender rear with the short bolts [B] in the front side, the long bolts [C] in the rear side and nuts [D].

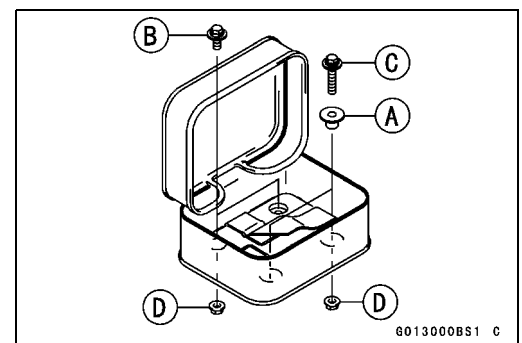

15-14 FRAME

Sidestand

Sidestand Removal

- Raise the rear wheel off the ground with the jack.

Special Tool - Jack: 57001-1238

- Remove:
 - Sidestand Switch Mounting Bolt [A]
 - Sidestand Switch Cover [B]
 - Sidestand Switch [C]

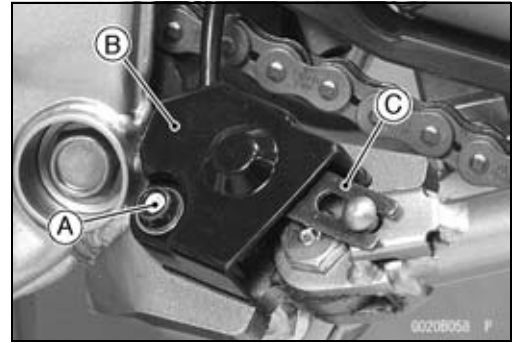

- Remove:
 - Spring [A]
 - Sidestand Nut [B]
 - Sidestand Bolt [C]
 - Sidestand [D]

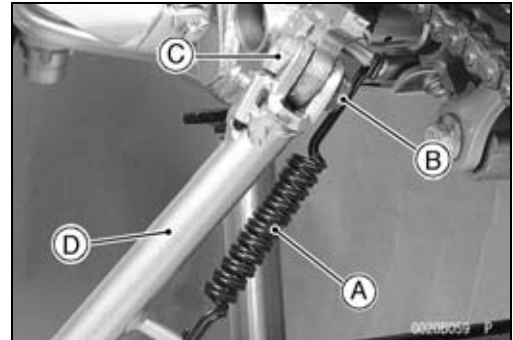

Sidestand Installation

- Apply grease to the sliding area [A] of the sidestand [B] and sidestand bolt [C].
- Replace the sidestand nut [D] with a new one.
- Tighten:
 - Torque - Sidestand Nut: 44 N·m (4.5 kgf·m, 32 ft·lb)
- Hook the spring [E] so that face the long spring end upward and spring ends direction as shown.

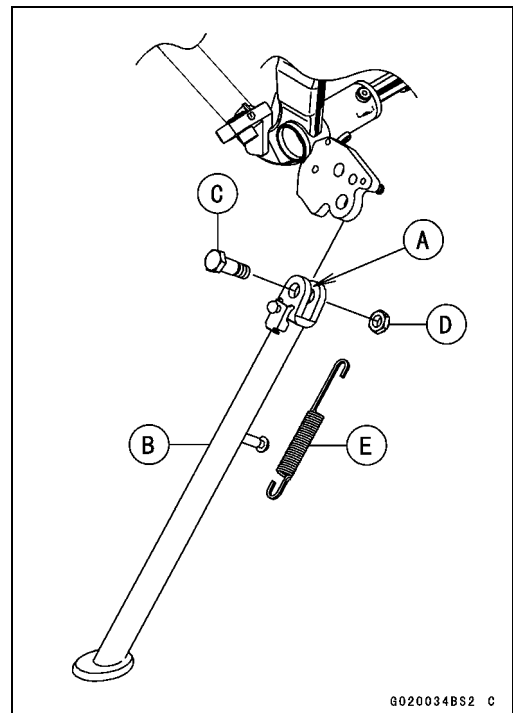

- Install the sidestand switch [A] as follows.
 - Insert the projection [B] into the hole [C].
 - Fit the slit [D] to the projection [E].

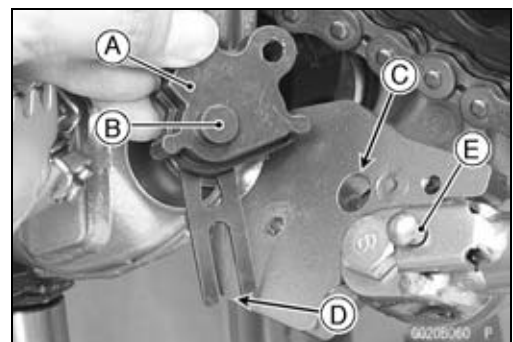

Sidestand

- Install the sidestand switch cover [A] as follows.
- Insert the projections [B] into the holes [C].
- Apply a non-permanent locking agent to the threads of the sidestand switch mounting bolt, and tighten it.

Torque - Sidestand Switch Mounting Bolt: 8.8 N·m (0.90 kgf·m, 78 in·lb)

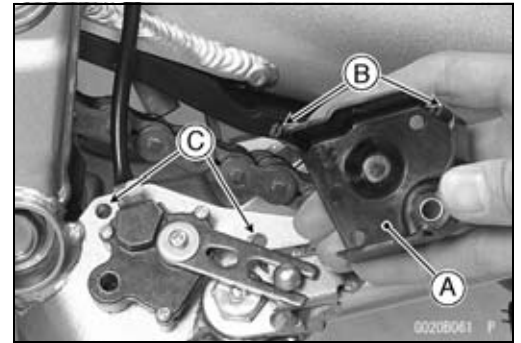

15-16 FRAME

Frame

Frame Inspection

- Visually inspect the frame [A] for cracks, dents, bending, or warping.
- ★ If there is any damage to the frame, replace it.

⚠ WARNING

A repaired frame may fail in use, possibly causing an accident resulting in injury or death. If the frame is bent, dented, cracked, or warped, replace it.

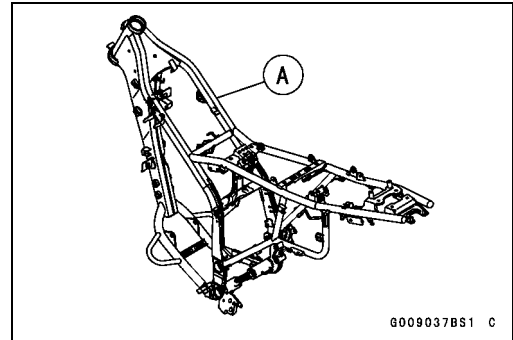

Electrical System

Table of Contents

Parts Location.....	16-3
Exploded View.....	16-6
Specifications.....	16-12
Special Tools and Sealant.....	16-13
Wiring Diagram (IN Model).....	16-16
Wiring Diagram (TH Model).....	16-18
Wiring Diagram (BR, EUR and SEA Models).....	16-20
Precautions.....	16-22
Electrical Wiring.....	16-24
Wiring Inspection.....	16-24
Battery.....	16-25
Battery Removal.....	16-25
Battery Installation.....	16-25
Battery Activation.....	16-26
Precautions.....	16-28
Interchange.....	16-29
Charging Condition Inspection.....	16-29
Refreshing Charge.....	16-29
Charging System.....	16-31
Alternator Cover Removal.....	16-31
Alternator Cover Installation.....	16-32
Alternator Rotor Removal.....	16-32
Alternator Rotor Installation.....	16-33
Stator Coil Removal.....	16-34
Stator Coil Installation.....	16-34
Alternator Inspection.....	16-34
Regulator/Rectifier Removal.....	16-36
Regulator/Rectifier Installation.....	16-36
Charging Voltage Inspection.....	16-36
Regulator/Rectifier Inspection.....	16-37
Ignition System.....	16-40
Ignition Timing Inspection.....	16-40
Crankshaft Sensor Removal.....	16-40
Crankshaft Sensor Installation.....	16-40
Crankshaft Sensor Inspection.....	16-41
Crankshaft Sensor Peak Voltage Inspection.....	16-41
Ignition Coil Removal.....	16-42
Ignition Coil Installation.....	16-42
Ignition Coil Inspection.....	16-43
Ignition Coil Primary Peak Voltage Inspection.....	16-44
Spark Plug Removal.....	16-44
Spark Plug Installation.....	16-45
Spark Plug Cleaning and Inspection.....	16-45
Interlock Operation Inspection.....	16-45
Interlock Diode Unit Inspection.....	16-46
IC Igniter Inspection.....	16-46
Starter Motor.....	16-49
Starter Motor Removal.....	16-49
Starter Motor Installation.....	16-49
Starter Motor Disassembly.....	16-50

16-2 ELECTRICAL SYSTEM

Starter Motor Assembly	16-51
Brush Inspection	16-53
Commutator Cleaning and Inspection.....	16-53
Armature Inspection.....	16-54
Brush Lead Inspection	16-54
End Cover Inspection.....	16-54
Starter Relay Removal.....	16-54
Starter Relay Inspection.....	16-55
Starter Circuit Relay Inspection	16-55
Lighting System.....	16-57
Headlight Body Removal	16-57
Headlight Aiming Inspection	16-57
Headlight Bulb Replacement	16-58
City Light Bulb Replacement (SEA, BR, IN and EUR Models).....	16-60
Tail/Brake Light Removal	16-60
Tail/Brake Light Bulb Replacement.....	16-61
Turn Signal Light Bulb Replacement	16-64
Turn Signal Relay Inspection	16-65
Air Switching Valve	16-67
Air Switching Valve Operation Test.....	16-67
Air Switching Valve Unit Test	16-67
Radiator Fan System.....	16-69
Radiator Fan Relay Inspection.....	16-69
Fan Motor Inspection	16-69
Meter, Gauge.....	16-71
Meter Unit Removal	16-71
Meter Unit Installation	16-71
Meter Unit Disassembly	16-71
Meter Unit Inspection.....	16-72
Speed Sensor Power Inspection.....	16-73
Switches and Sensors	16-81
Water Temperature Sensor Inspection	16-81
Speed Sensor Removal.....	16-81
Speed Sensor Installation.....	16-82
Speed Sensor Inspection.....	16-82
Fuel Reserve Switch Inspection.....	16-83
Oxygen Sensor Removal.....	16-83
Oxygen Sensor Installation	16-84
Oxygen Sensor Inspection.....	16-84
Oxygen Sensor Heater Inspection	16-84
Sidestand Switch Removal	16-84
Sidestand Switch Installation	16-85
Brake Light Timing Inspection.....	16-85
Brake Light Timing Adjustment	16-85
Switch Inspection	16-86
Fuse.....	16-87
20 A Main Fuse Removal.....	16-87
Fuse Box Fuse Removal.....	16-87
Fuse Installation.....	16-87
Fuse Inspection.....	16-88

Parts Location

- 1. Meter Unit
- 2. Ignition Switch

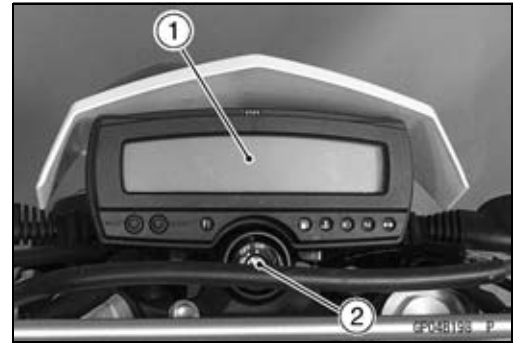

- 3. Front Brake Light Switch
- 4. Right Handlebar Switch

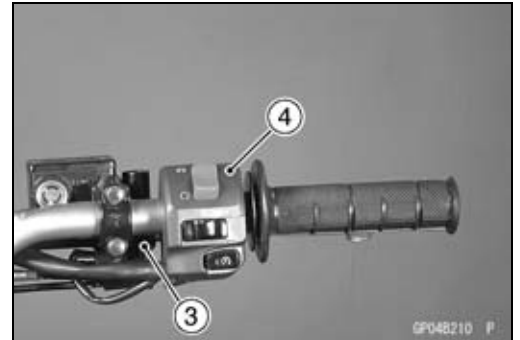

- 5. Left Handlebar Switch
- 6. Starter Lockout Switch

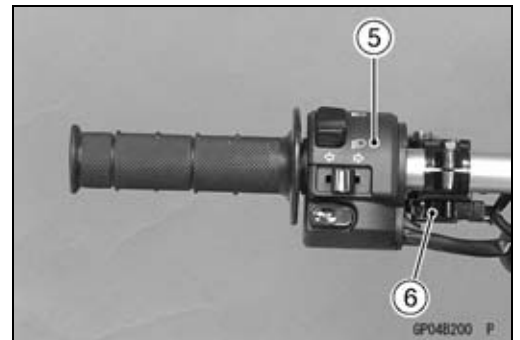

- 7. Horn
- 8. Ignition Coil
- 9. Spark Plug
- 10. Water Temperature Sensor
- 11. Air Switching Valve

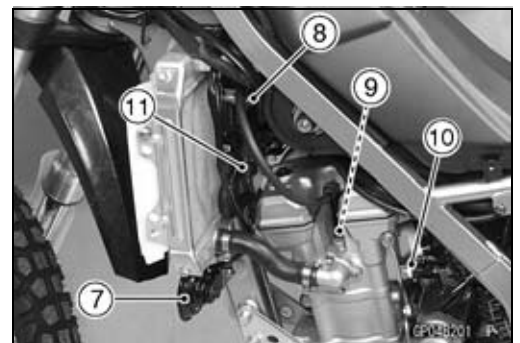

- 12. Starter Motor
- 13. Regulator/Rectifier
- 14. Alternator
- 15. Crankshaft Sensor

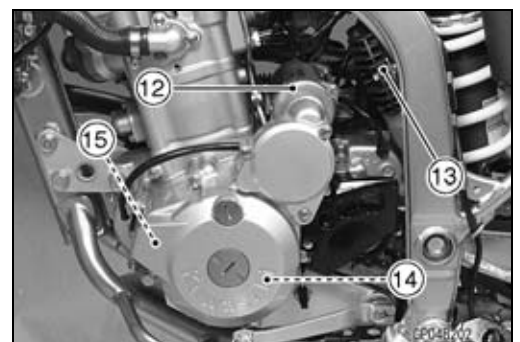

16-4 ELECTRICAL SYSTEM

Parts Location

- 16. Neutral Switch
- 17. Sidestand Switch



- 18. Starter Circuit Relay
- 19. Interlock Diode Unit
- 20. Starter Relay, Main Fuse 20 A
- 21. Fuse Box
- 22. Radiator Fan Relay
- 23. Turn Signal Relay

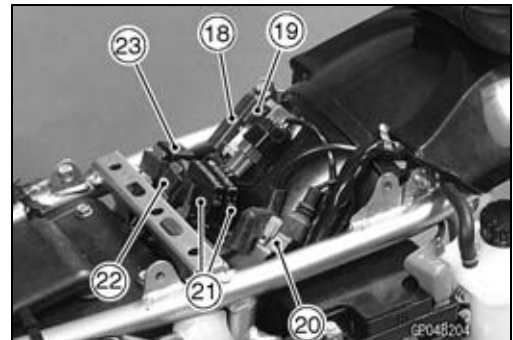

- 24. Battery 12 V 6 Ah



- 25. Radiator Fan Motor



- 26. Rear Brake Light Switch



Parts Location

27. Speed Sensor



16-6 ELECTRICAL SYSTEM

Exploded View

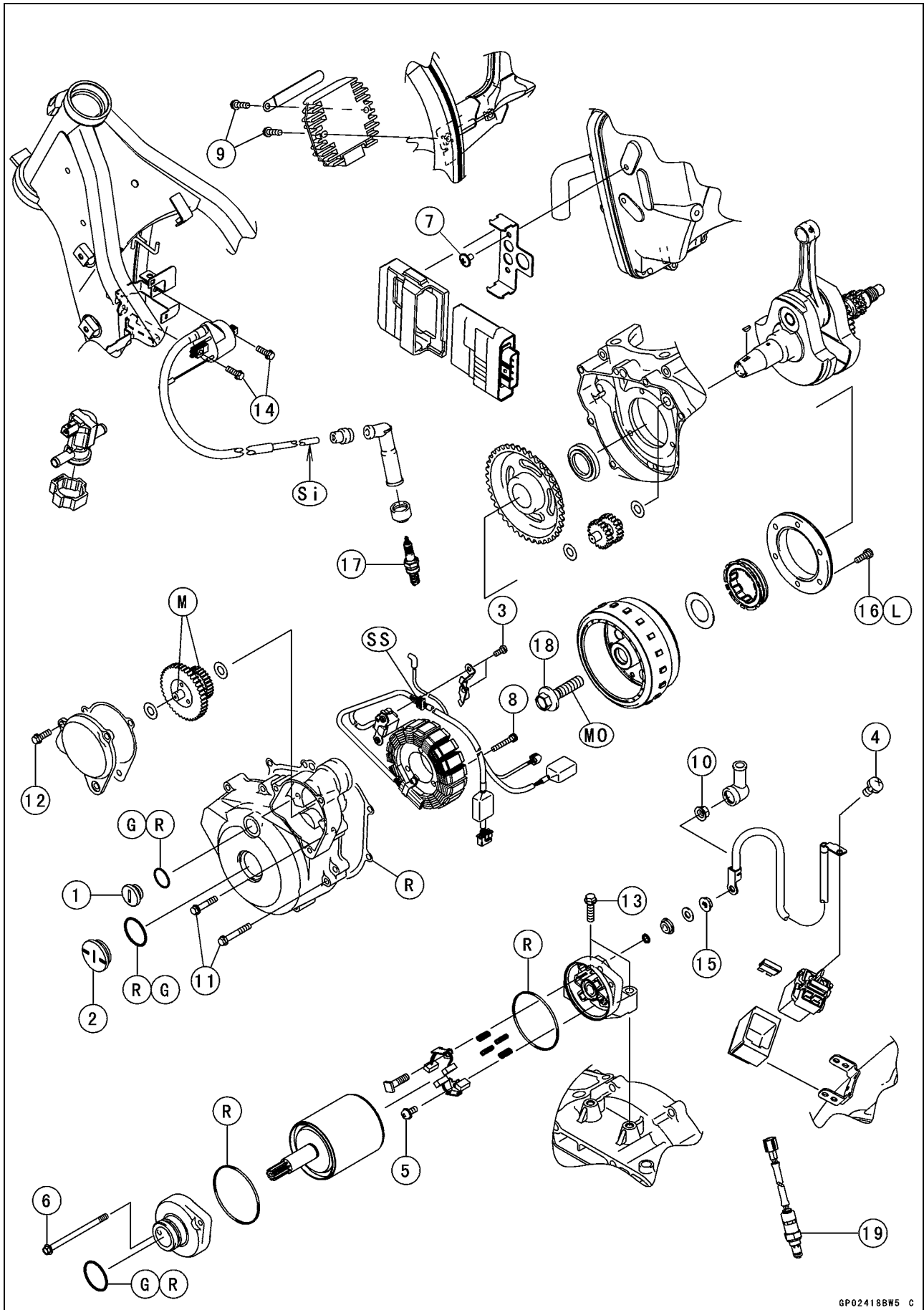

Exploded View

No.	Fastener	Torque			Remarks
		N·m	kgf·m	ft·lb	
1	Timing Inspection Cap	2.3	0.23	20 in·lb	
2	Alternator Rotor Bolt Cap	2.3	0.23	20 in·lb	
3	Crankshaft Sensor Screws	2.4	0.24	21 in·lb	
4	Starter Relay Terminal Screws	2.4	0.24	21 in·lb	
5	Negative Brush Assy Mounting Screw	3.8	0.39	34 in·lb	
6	Starter Motor Assy Bolts	5.0	0.51	44 in·lb	
7	ECU Bracket Screws	5.0	0.51	44 in·lb	
8	Stator Coil Mounting Bolts	5.9	0.60	52 in·lb	
9	Regulator/Rectifier Mounting Bolts	9.8	1.0	87 in·lb	
10	Starter Motor Cable Nut	9.8	1.0	87 in·lb	
11	Alternator Cover Bolts	9.8	1.0	87 in·lb	
12	Torque Limiter Cover Bolts	9.8	1.0	87 in·lb	
13	Starter Motor Mounting Bolts	9.8	1.0	87 in·lb	
14	Ignition Coil Mounting Bolts	9.8	1.0	87 in·lb	
15	Starter Motor Terminal Locknut	11	1.1	97 in·lb	
16	Starter Motor Clutch Bolts	12	1.2	106 in·lb	L
17	Spark Plug	13	1.3	115 in·lb	
18	Alternator Rotor Bolt	120	12.2	88.5	MO
19	Oxygen Sensor	25	2.5	18	

G: Apply grease.

L: Apply a non-permanent locking agent.

M: Apply molybdenum disulfide grease.

MO: Apply molybdenum disulfide oil (mixture of engine oil and molybdenum disulfide grease in a weight ratio is 10 : 1).

R: Replacement Parts

Si: Apply silicone grease.

SS: Apply silicone sealant.

16-8 ELECTRICAL SYSTEM

Exploded View

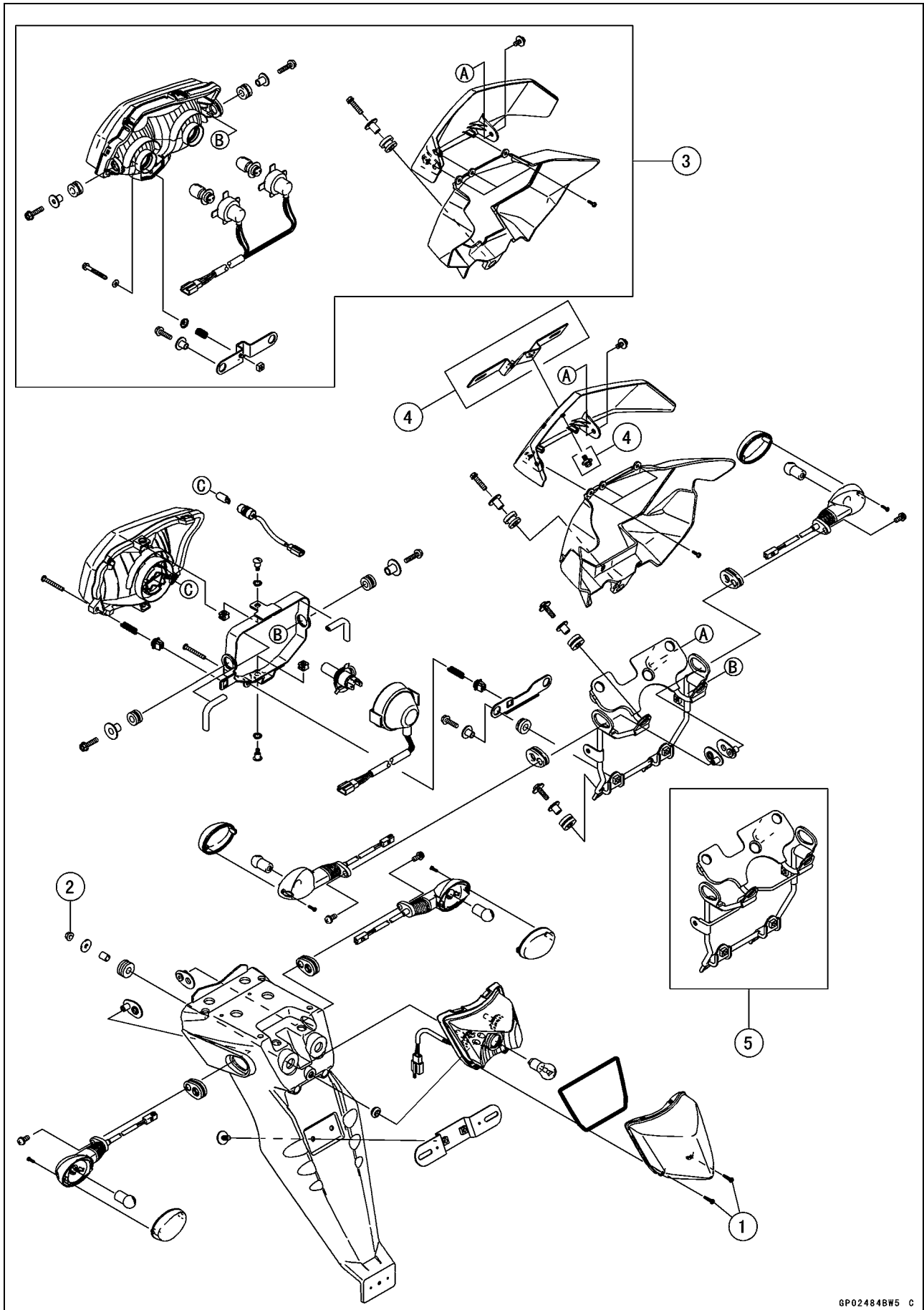

Exploded View

No.	Fastener	Torque			Remarks
		N·m	kgf·m	ft·lb	
1	Tail/Brake Light Lens Screws	1.0	0.10	8.8 in·lb	
2	Tail/Brake Light Mounting Nuts	5.9	0.60	52 in·lb	

3. TH Model

4. IN Model

5. KLX250S9F Late Model ~ SBF (TH)/V9F Late Model ~ VAF (TH)

16-10 ELECTRICAL SYSTEM

Exploded View

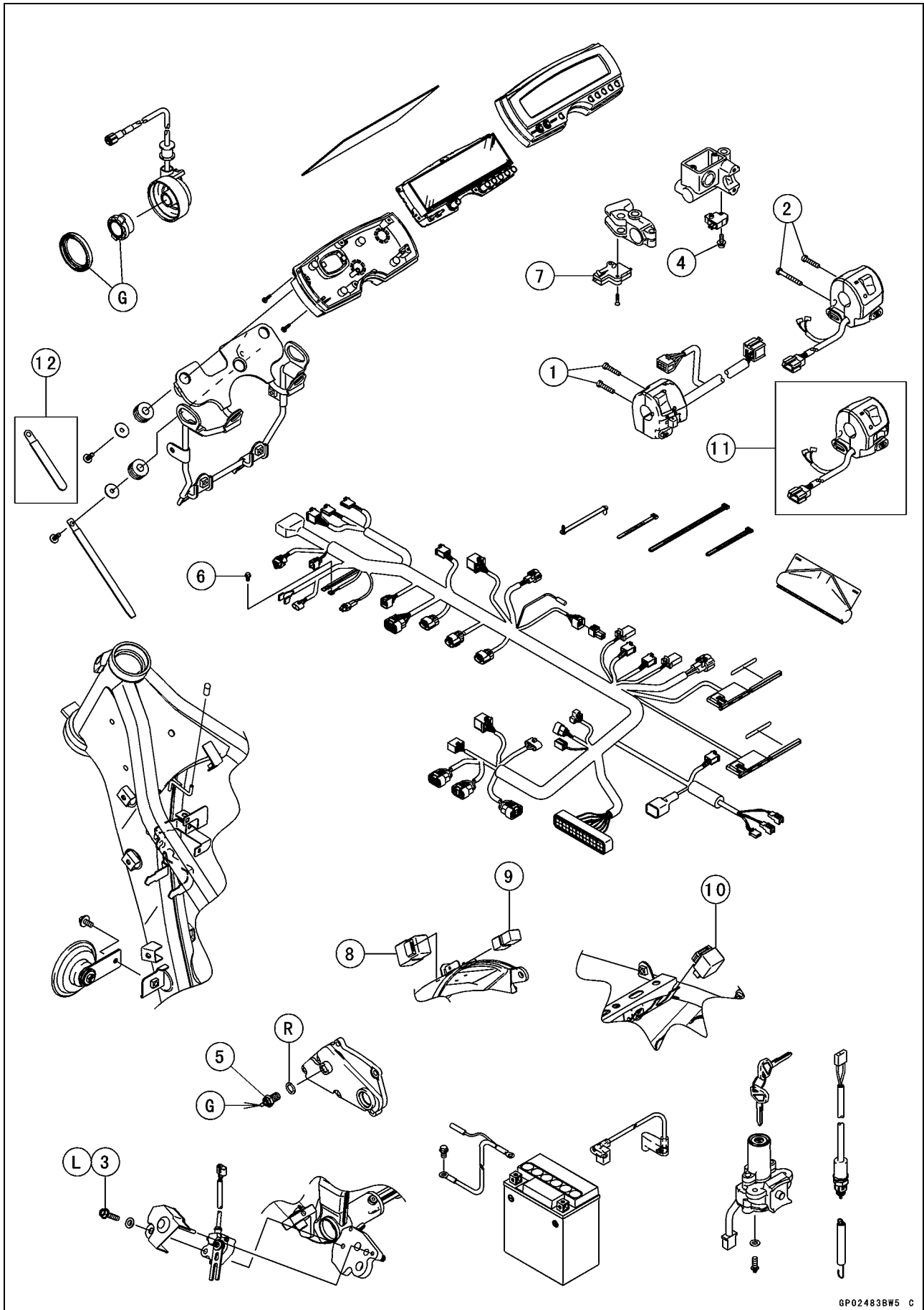

Exploded View

No.	Fastener	Torque			Remarks
		N·m	kgf·m	ft·lb	
1	Left Switch Housing Screws	3.5	0.36	31 in·lb	
2	Right Switch Housing Screws	3.5	0.36	31 in·lb	
3	Sidestand Switch Mounting Bolt	8.8	0.90	78 in·lb	L
4	Front Brake Light Switch Mounting Screw	1.2	0.12	11 in·lb	
5	Neutral Switch	14.7	1.5	130 in·lb	G
6	Engine Ground Terminal Bolt	9.8	1.0	87 in·lb	

- 7. Starter Lockout Switch
- 8. Starter Circuit Relay
- 9. Interlock Diode Unit
- 10. Turn Signal Relay
- 11. IN Model
- 12. KLX250S9F Early Model/V9F Early Model
- G: Apply grease.
- L: Apply a non-permanent locking agent.
- R: Replacement Parts

16-12 ELECTRICAL SYSTEM

Specifications

Fastener	Standard
Battery Type Model Name Capacity Voltage	Sealed battery FTX7L-BS 12 V 6 Ah 12.6 V or more
Charging System Type Charging Voltage (Regulator/Rectifier Output Voltage) Alternator output voltage (no load) Stator Coil Resistance	Three-phase AC 14.2 ~ 15.2 V 45 V or more @4 000 r/min (rpm) 0.3 ~ 1.0 Ω
Ignition System Ignition Coil: 3 Needle Arcing Distance Primary Winding Resistance Secondary Winding Resistance Primary Peak Voltage Spark Plug: Type Spark Plug Gap Spark Plug Cap Resistance Crankshaft Sensor: Crankshaft Sensor Resistance Crankshaft Sensor Peak Voltage	6 mm (0.24 in.) or more 0.17 ~ 0.23 Ω @20°C (68°F) 5.0 ~ 7.6 k Ω @20°C (68°F) 120 V or more NGK CR8E or ND U24ESR-N 0.7 ~ 0.8 mm (0.028 ~ 0.031 in.) 3.75 ~ 6.25 k Ω Approx. 240 Ω @20°C (68°F) 3.7 V or more
Electrical Starter System Starter Motor: Brush Length	12 mm (0.47 in.) (Service Limit: 6.5 mm (0.26 in.))
Air Switching Valve Resistance	24 ~ 28 Ω @ 20°C (68°F)
Switch and Sensor Rear Break Light Switch Timing Water Temperature Sensor Resistance	On after about 10 mm (0.39 in.) pedal travel see text

Special Tools and Sealant

Rotor Puller, M16/M18/M20/M22 × 1.5 :
57001-1216

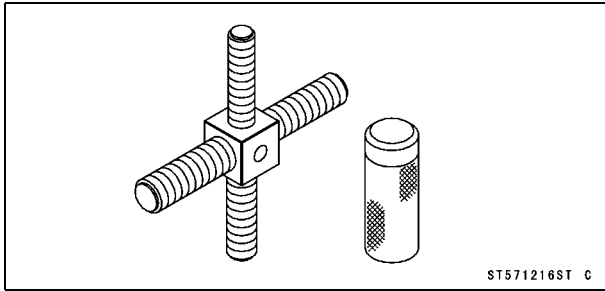

Peak Voltage Adapter:
57001-1415

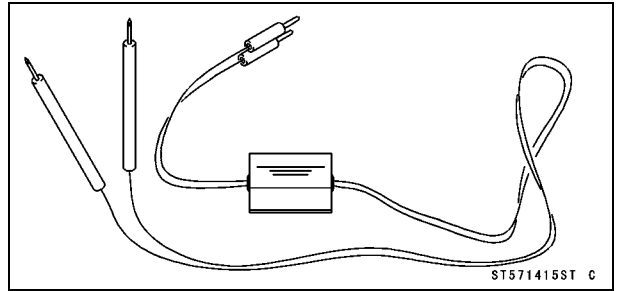

Jack:
57001-1238

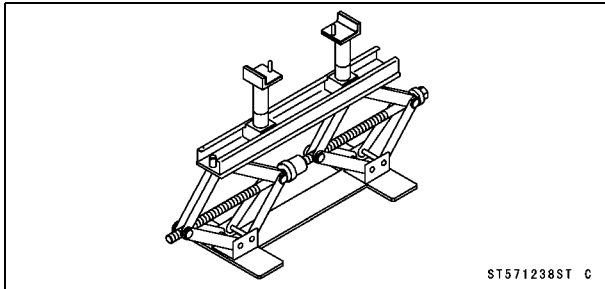

Filler Cap Driver:
57001-1454

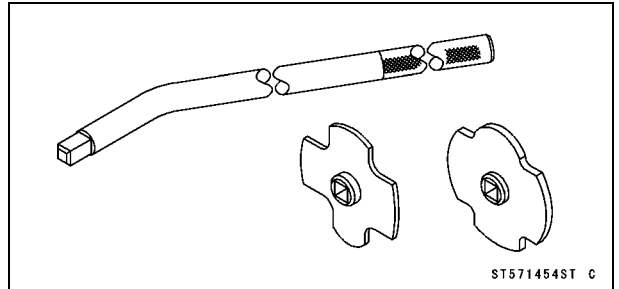

Timing Light:
57001-1241

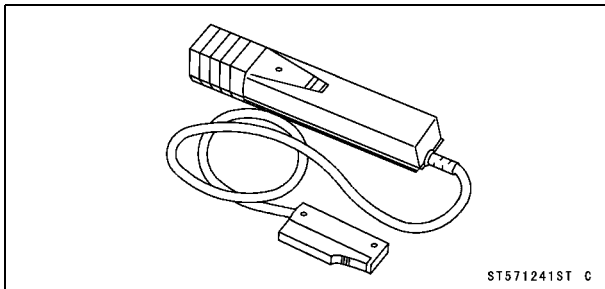

Needle Adapter Set:
57001-1457

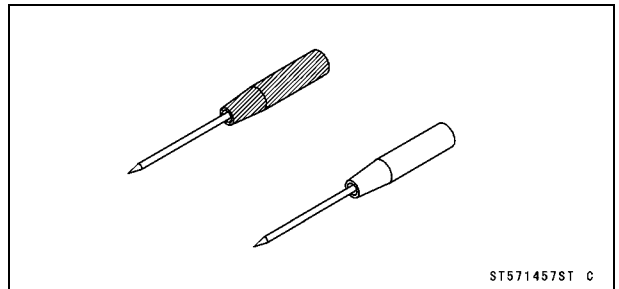

Spark Plug Wrench, Hex 16:
57001-1262

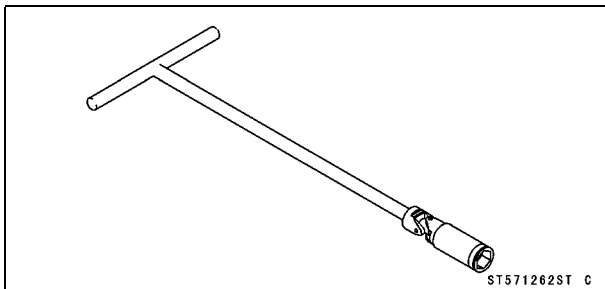

Grip:
57001-1591

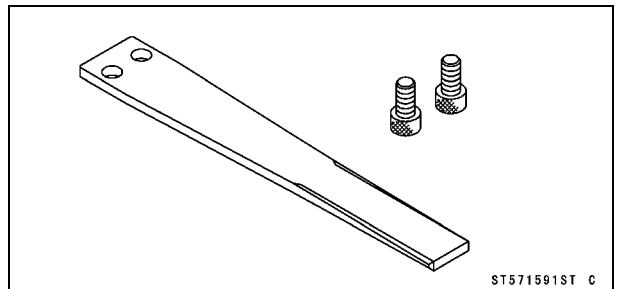

Hand Taster:
57001-1394

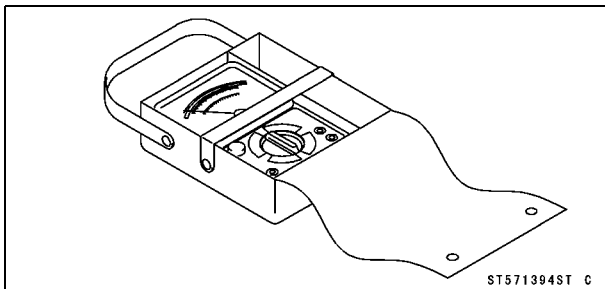

Rotor Holder:
57001-1723

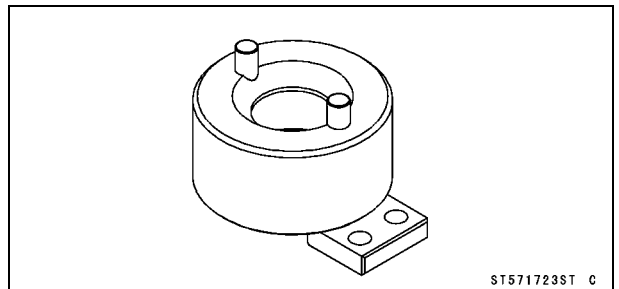

16-14 ELECTRICAL SYSTEM

Special Tools and Sealant

Liquid Gasket, TB1211F:

92104-0004

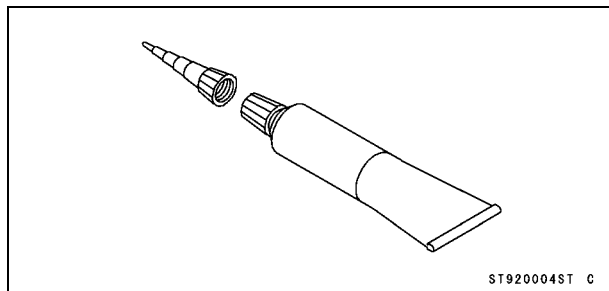

Special Tools and Sealant

This page intentionally left blank.

16-16 ELECTRICAL SYSTEM

Wiring Diagram (IN Model)

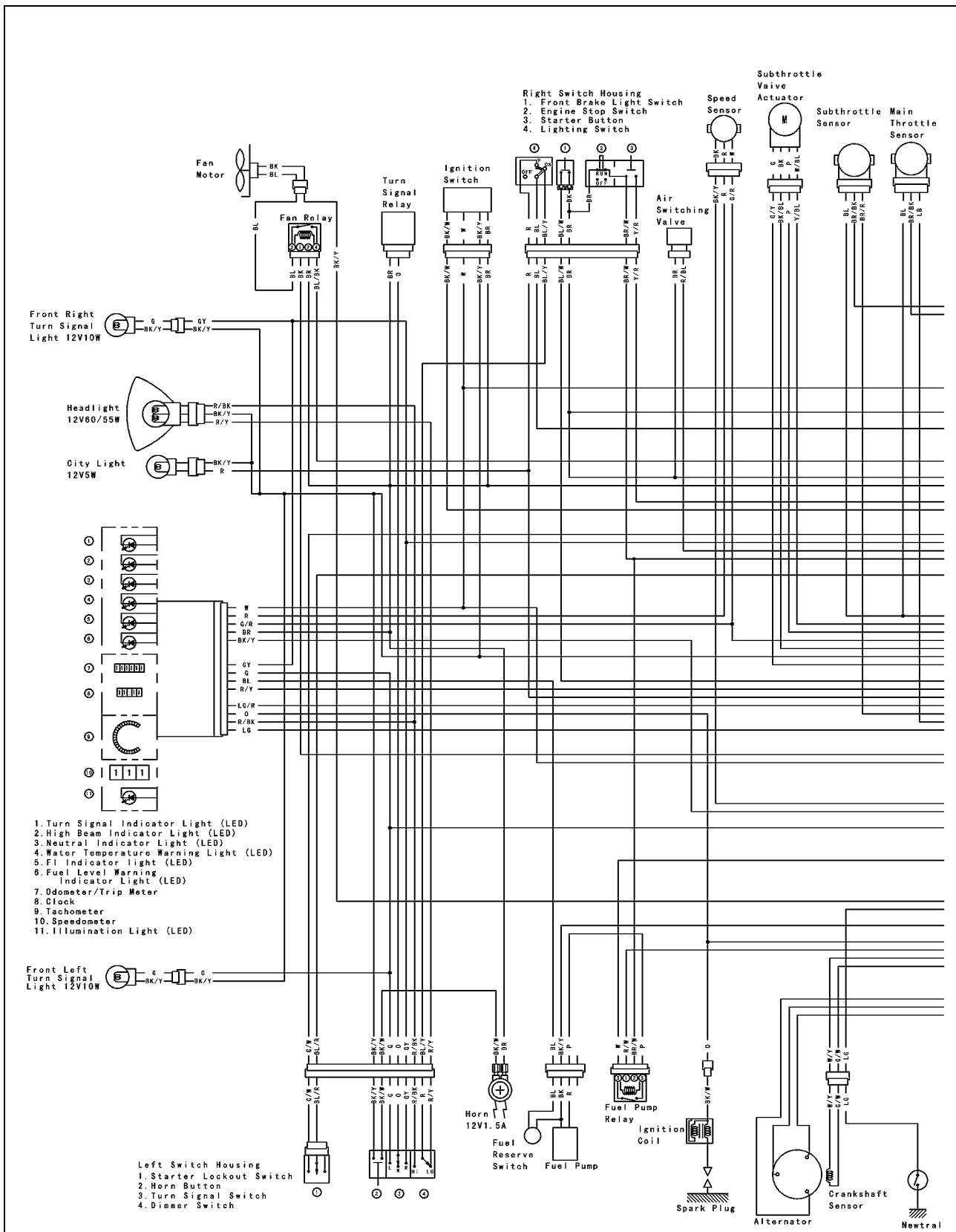

LEFT SWITCH HOUSING CONNECTIONS												
Starter Lockout Switch		Horn Button		Turn Signal Switch			Dimmer Switch					
Color	G/W	BL/R	Color	BK/Y	BK/W	Color	G	O	GY	R/BK	R	R/Y
ON			Push			L				HI		
OFF			Released			OFF (Push)				LO		

LIGHTING SWITCH			
Position	L	R	L/Y
OFF			
Position			
ON			

Wiring Diagram (IN Model)

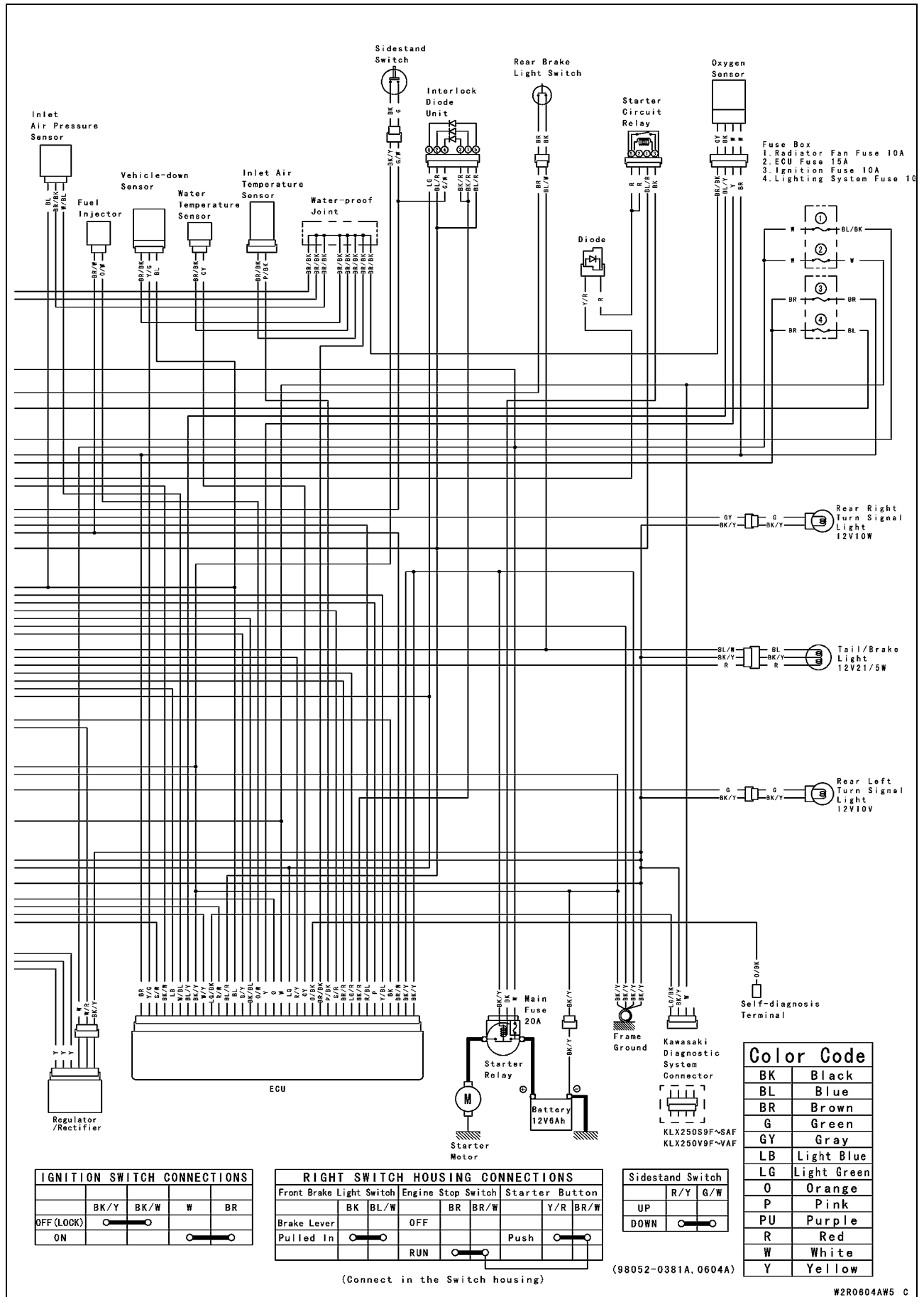

16-18 ELECTRICAL SYSTEM

Wiring Diagram (TH Model)

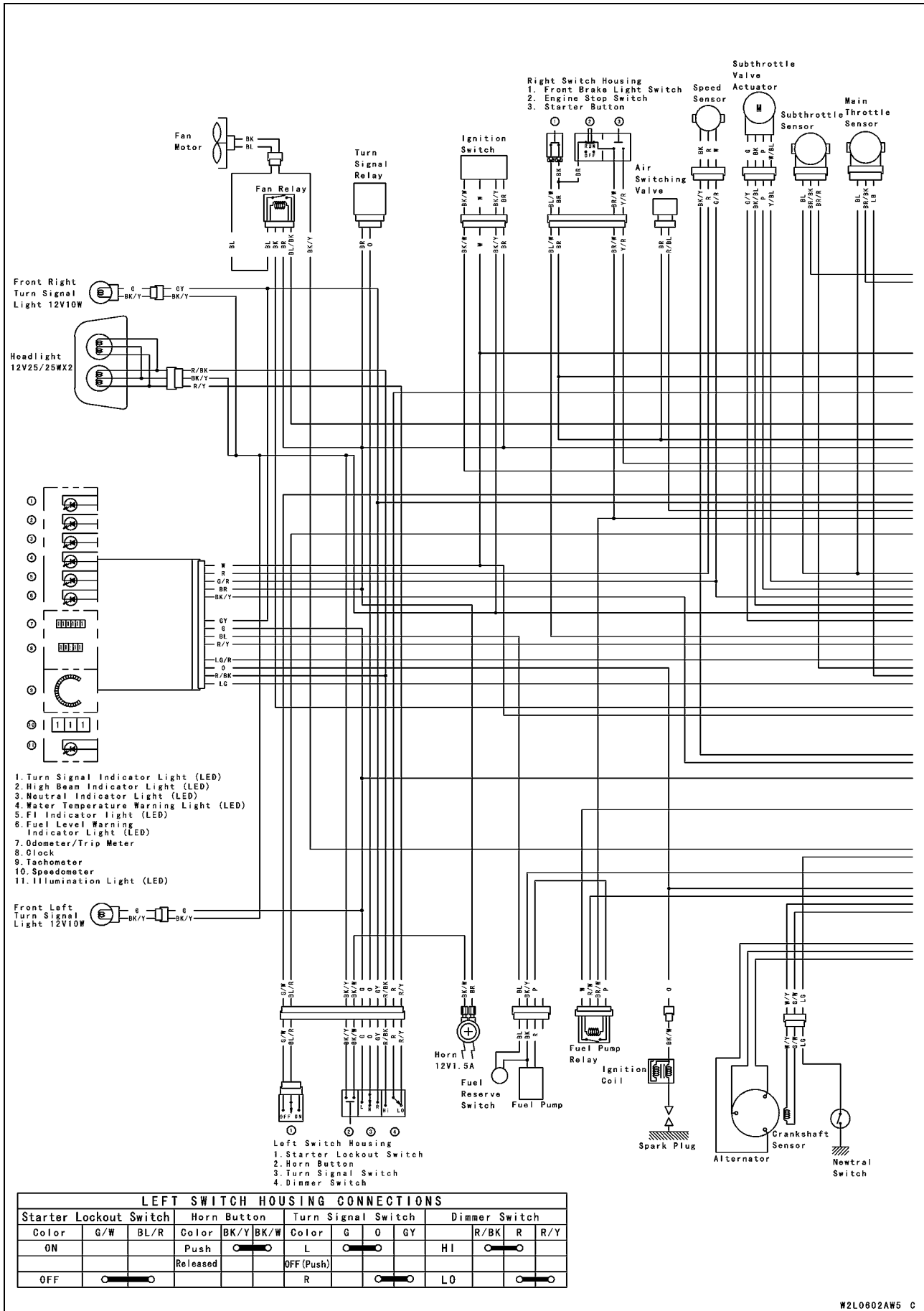

Wiring Diagram (TH Model)

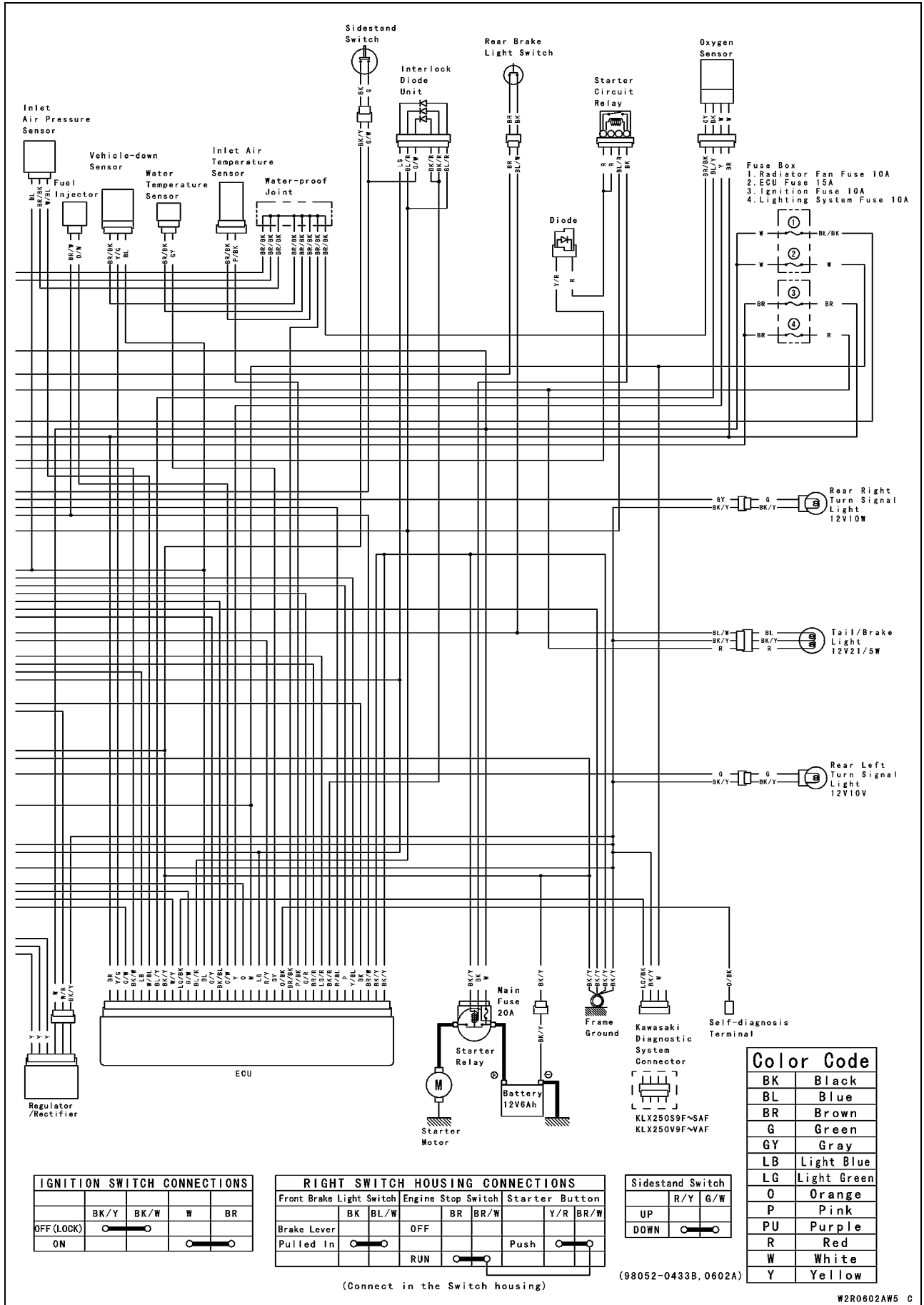

16-20 ELECTRICAL SYSTEM

Wiring Diagram (BR, EUR and SEA Models)

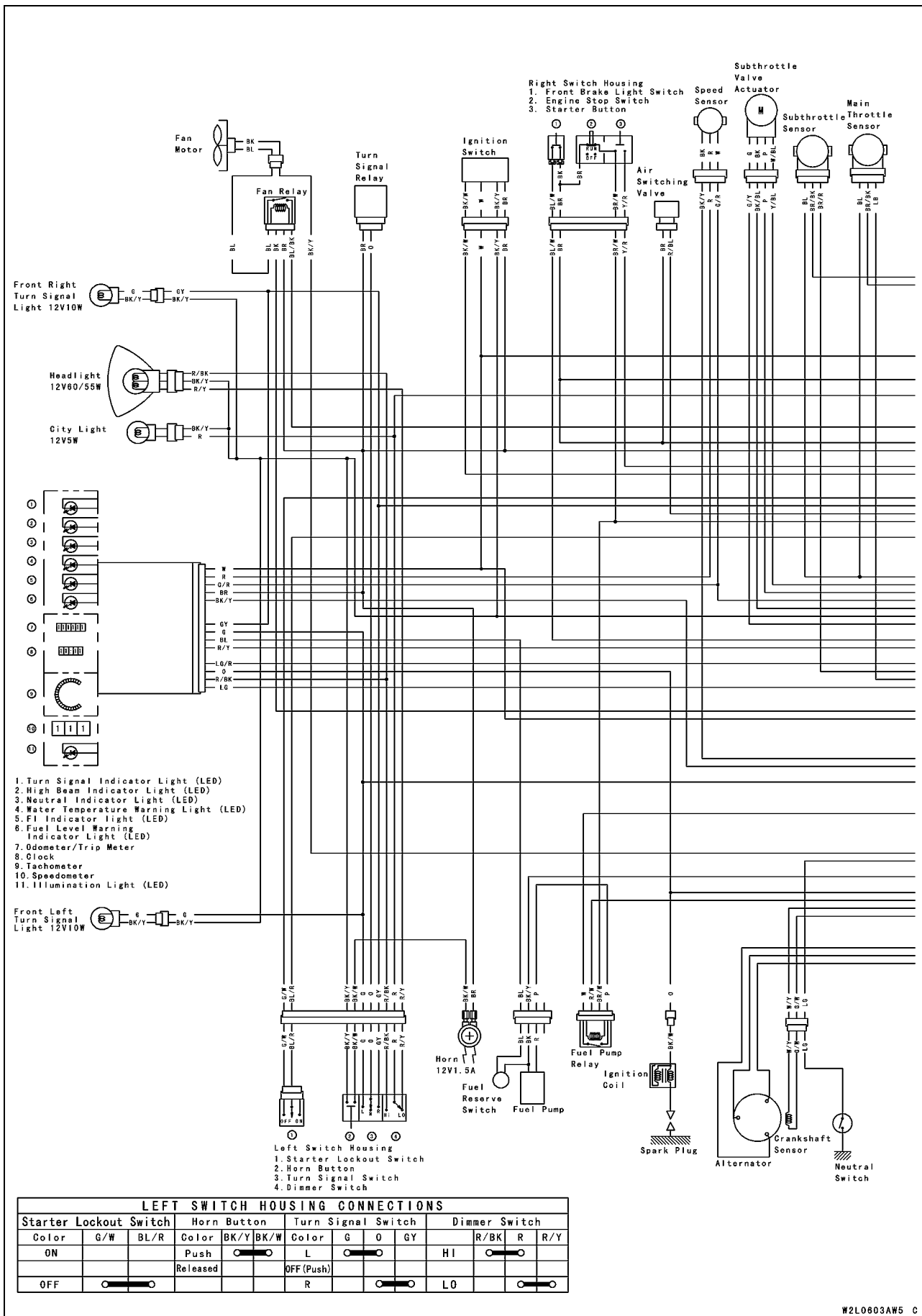

Wiring Diagram (BR, EUR and SEA Models)

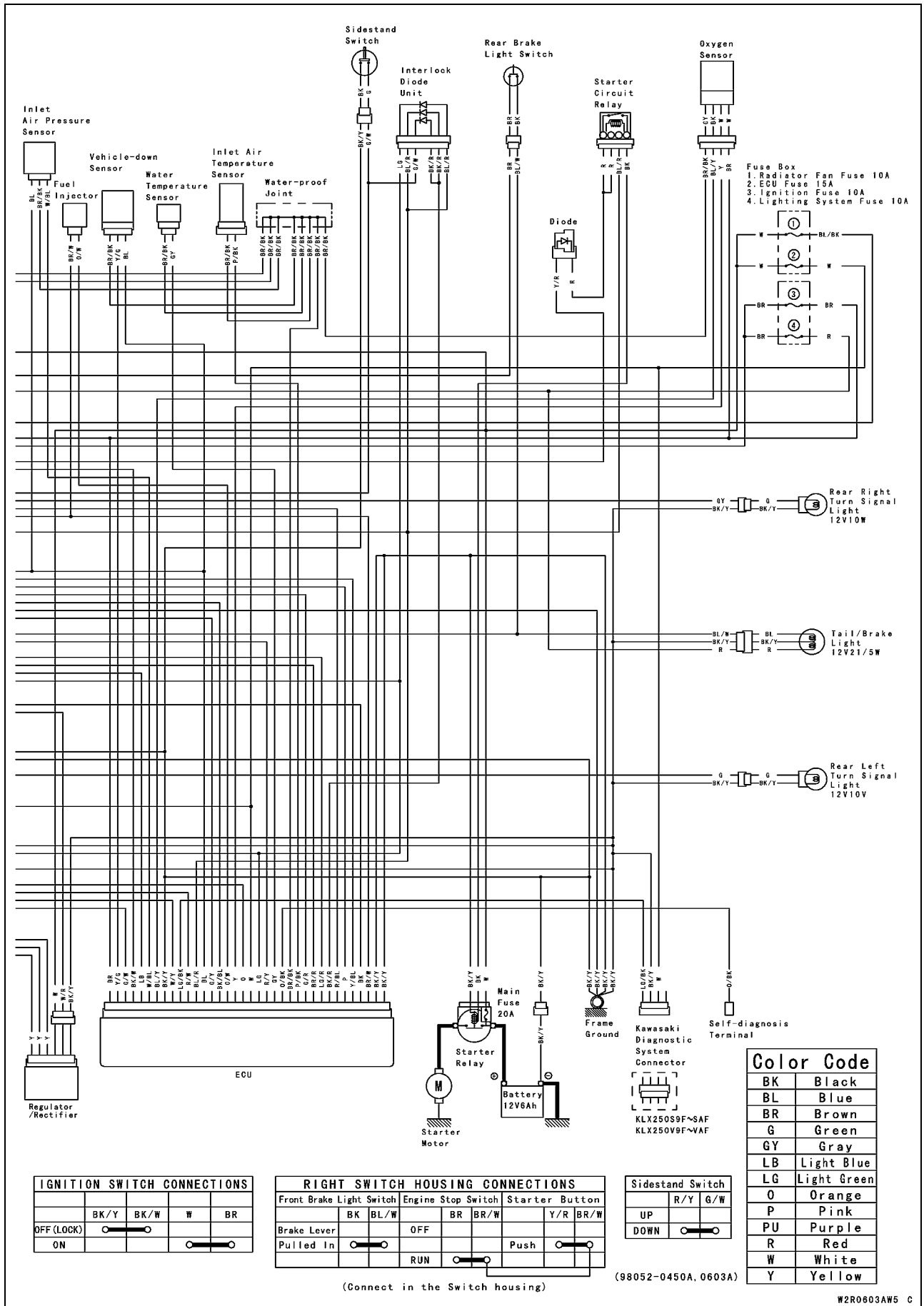

16-22 ELECTRICAL SYSTEM

Precautions

There are numbers of important precautions that are musts when servicing electrical systems. Learn and observe all the rules below:

- Do not reverse the battery cable connections. This will burn out the diodes in the electrical parts.
- Always check battery condition before condemning other parts of an electrical system. A fully charged battery is a must for conducting accurate electrical system tests.
- The electrical parts should never be struck sharply, as with a hammer, or allowed to fall on a hard surface. Such a shock to the parts can damage them.
- To prevent damage to electrical parts, do not disconnect the battery cables or any other electrical connections when the ignition switch is ON, or while the engine is running.
- Because of the large amount of current, never keep the starter button pushed when the starter motor will not turn over, or the current may burn out the starter motor windings.
- Take care not to short the cables that are directly connected to the battery positive (+) terminal to the chassis ground.
- Troubles may involve one or in some cases all items. Never replace a defective part without determining what CAUSED the failure. If the failure was caused by some other item or items, they must be repaired or replaced, or the new replacement will soon fail again.
- Make sure all connectors in the circuit are clean and tight, and examine leads for signs of burning, fraying, etc. Poor leads and bad connections will affect electrical system operation.
- Measure coil and winding resistance when the part is cold (at room temperature).
- Color Code

BK: Black	GY: Gray	R: Red
BL: Blue	LG: Light green	W: White
BR: Brown	O: Orange	Y: Yellow
G: Green		

- Electrical Connectors
Connectors [A]

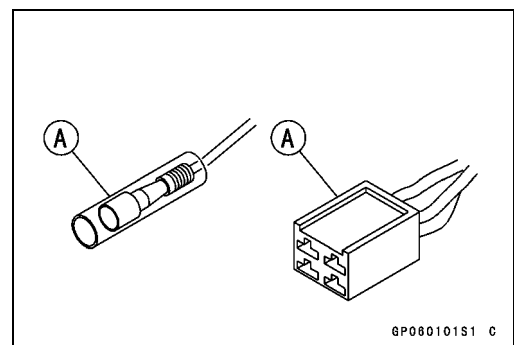

Precautions

Connectors [B]

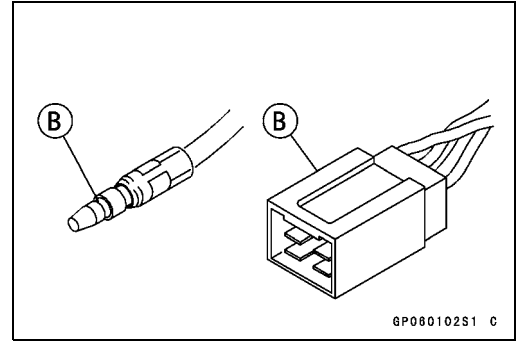

16-24 ELECTRICAL SYSTEM

Electrical Wiring

Wiring Inspection

- Visually inspect the wiring for signs of burning, fraying, etc.
- ★ If any wiring is poor, replace the damaged wiring.
- Pull each connector [A] apart and inspect it for corrosion, dirt, and damage.
- ★ If the connector is corroded or dirty, clean it carefully. If it is damaged, replace it.
- Check the wiring for continuity.
- Use the wiring diagram to find the ends of the lead which is suspected of being a problem.
- Connect the hand tester between the ends of the leads.

Special Tool - Hand Tester: 57001-1394

- Set the tester to the $\times 1 \Omega$ range, and read the tester.
- ★ If the tester does not read 0Ω , the lead is defective. Replace the lead or the wiring harness [B] if necessary.

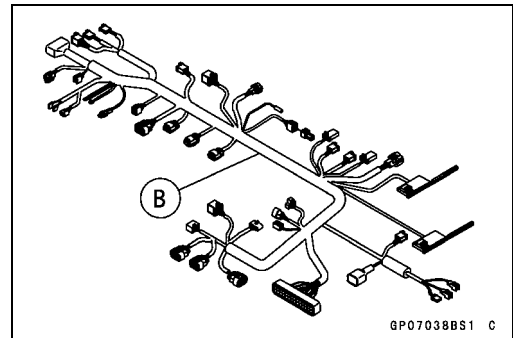
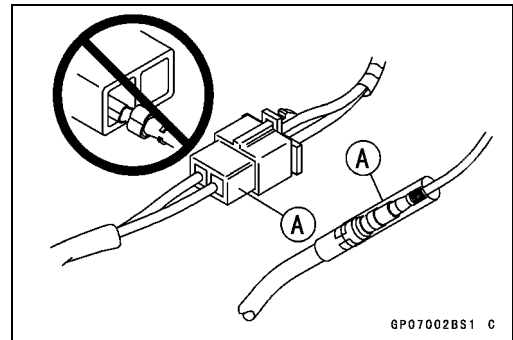

Battery

Battery Removal

NOTICE

Do not disconnect the battery cables or any other electrical connections when the ignition switch is ON, as this could damage the igniter. Never reverse the connections of the battery, as this could damage the igniter.

- Turn the ignition switch OFF.
- Remove the left side cover (see Side Cover Removal in the Frame chapter).
- Slide the red cap [A] out.
- Disconnect the negative (-) cable [B] and then positive (+) cable [C].

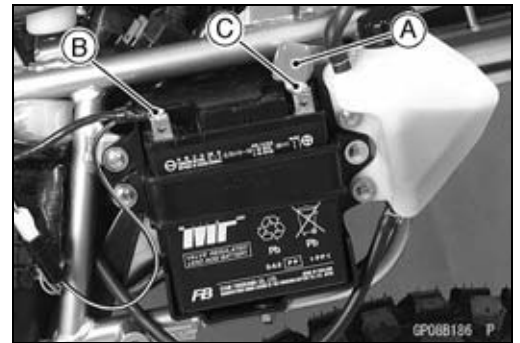

- Remove:
 - Bolts [A]
 - Battery Holder [B]
- Pull the battery [C] out of the case.
- Clean the battery using a solution of baking soda and water. Make sure that the cable connection terminals are not soiled.

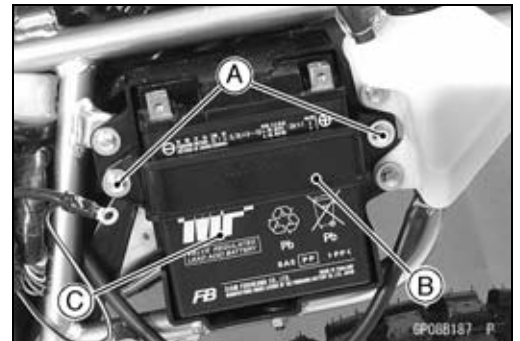

Battery Installation

- Visually inspect the surface of the battery container.
- ★ Check if there are any signs of cracking or electrolyte leakage from the sides of the battery.
- Face the (-) terminal forward and put the battery [A] into the battery case.
- Set the battery holder [B] into the battery case.
- Tighten the battery holder bolts [C] securely.

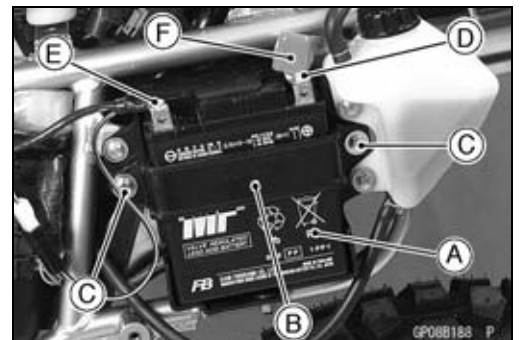

NOTICE

If each battery cable is not correctly disconnected or connected, sparks can arise at electrical connections, causing damage to electrical parts.

- Connect the positive (+) cable [D] (red cap) to the (+) terminal first, and then the negative (-) cable [E] to the (-) terminal.
- Apply a little grease to the terminal for rust protection.
- Cover the terminal with the red cap [F].
- Install the left side cover (see Side Cover Installation in the Frame chapter).

NOTICE

A failure to detach or connect the battery cables properly will cause the generation of sparks at connection terminals and resultant damages to electrical components.

16-26 ELECTRICAL SYSTEM

Battery

Battery Activation

Electrolyte Filling

- Make sure that the model name [A] of the electrolyte container matches the model name [B] of the battery. These names must be the same.

Battery Model Name: FTX7L-BS

NOTICE

Be sure to use the electrolyte container with the same model name as the battery since the electrolyte volume and specific gravity vary with the battery type. This is to prevent overfilling of the electrolyte, shorting the battery life, and deterioration of the battery performance.

NOTICE

Do not remove the aluminum sealing sheet [A] from the filler ports [B] until just prior to use. Be sure to use the dedicated electrolyte container for correct electrolyte volume.

- Place the battery on a level surface.
- Check to see that the sealing sheet has no peeling, tears, or holes in it.
- Remove the sealing sheet.

NOTE

○The battery is vacuum sealed. If the sealing sheet has leaked air into the battery, it may require a longer initial charge.

- Remove the electrolyte container from the vinyl bag.
- Detach the strip of caps [A] from the container and set aside, these will be used later to seal the battery.

NOTE

○Do not pierce or otherwise open the sealed cells [B] of the electrolyte container. Do not attempt to separate individual cells.

- Place the electrolyte container upside down with the six sealed cells into the filler ports of the battery. Hold the container level, push down to break the seals of all six cells. You will see air bubbles rising into each cell as the ports fill.

NOTE

○Do not tilt the electrolyte container

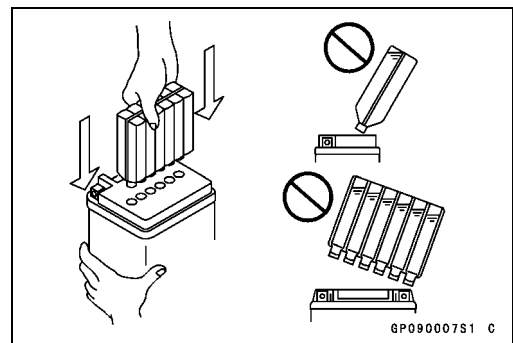
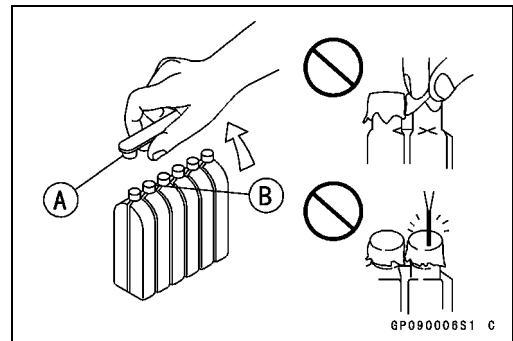
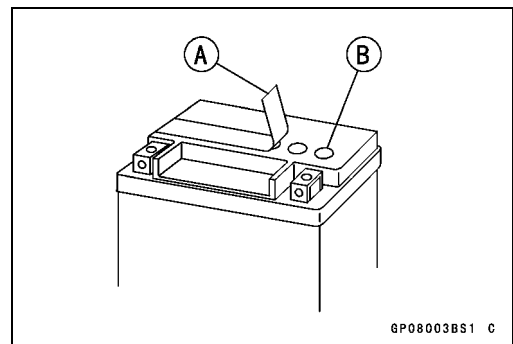
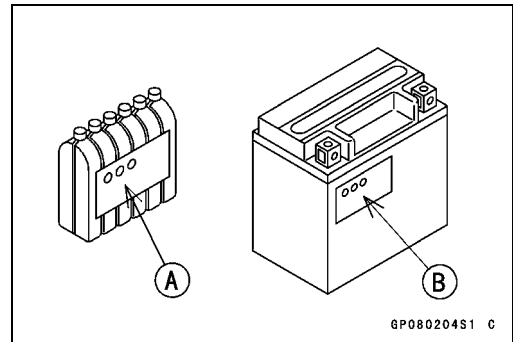

Battery

- Check the electrolyte flow.
- ★ If no air bubbles [A] are coming up from the filler ports, or if the container cells have not emptied completely, tap the container [B] a few times.
- Keep the container in place for **20** minutes or more. Don't remove the container from the battery until it's empty, the battery requires all the electrolyte from the container for proper operation.

NOTICE

Removal of the container before it is completely empty can shorten the service life of the battery. Do not remove the electrolyte container until it is completely empty and 20 minutes have elapsed.

- Gently remove the container from the battery.
- Let the battery sit for **30** minutes prior to charging to allow the electrolyte to permeate into the plates for optimum performance.

NOTE

○ *Charging the battery immediately after filling can shorten service life. Let the battery sit for at least 30 minutes after filling.*

Initial Charge

- Place the strip [A] of caps loosely over the filler ports.
- Newly activated sealed batteries require an initial charge.

Standard Charge 0.7 A × 5 ~ 10 hours

- ★ If using a recommended battery charger, follow the charger's instructions for newly activated sealed battery.

Kawasaki-recommended chargers:

Battery Mate 150-9

OptiMate PRO 4-S/PRO S/PRO2

Yuasa MB-2040/2060

Christie C10122S

- ★ If the above chargers are not available, use equivalent one.

NOTE

○ *Charging rates will vary depending on how long the battery has been stored, temperature, and the type of charger used. Let battery sit 30 minutes after initial charge, then check voltage using a voltmeter. If it is not at least 12.6 volts, repeat charging cycle.*

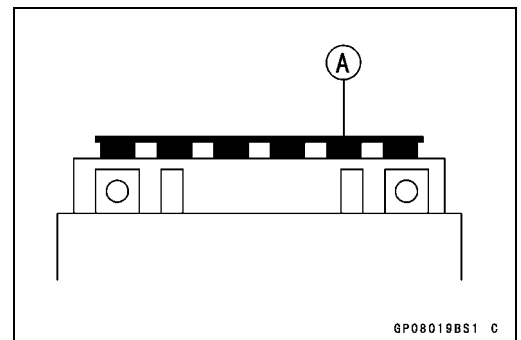
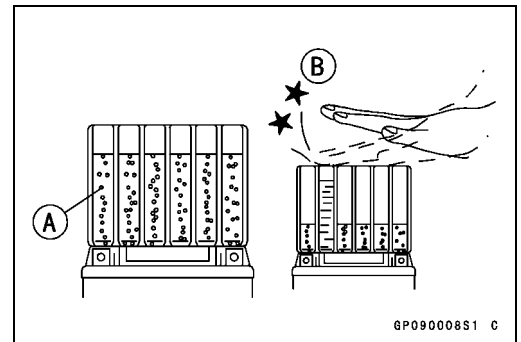

16-28 ELECTRICAL SYSTEM

Battery

- After charging is completed, press down firmly with both hands to seat the strip of caps [A] into the battery (don't pound or hammer). When properly installed, the strip of the caps will be level with the top of the battery.

NOTICE

Once the strip of the caps [A] is installed onto the battery, never remove the caps, nor add water or electrolyte to the battery.

NOTE

- To ensure maximum battery life and customer satisfaction, it is recommended the battery be load tested at three times its amp-hour rating for 15 seconds. Re-check voltage and if less than 12.6 volts repeat the charging cycle and load test. If still below 12.6 volts the battery is defective.

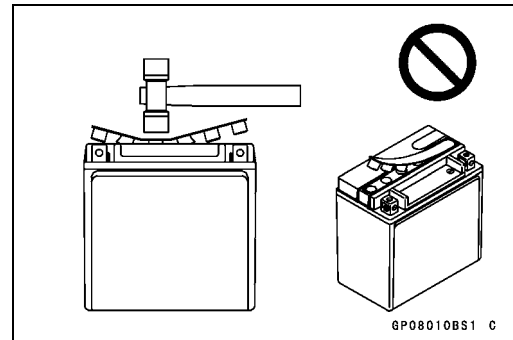
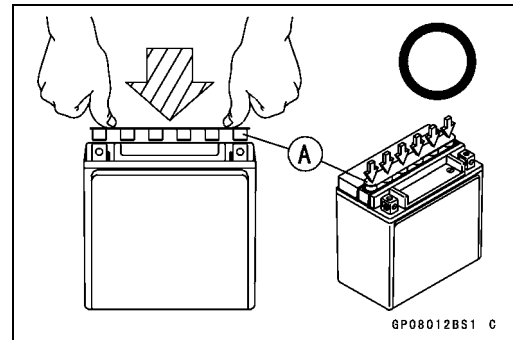

Precautions

- 1) No need of topping-up
No topping-up is necessary in this battery until it ends its life under normal use. Forcibly prying off the seal cap to add water is very dangerous. Never do that.
- 2) Refreshing charge
If an engine will not start, a horn sounds weak, or lamps are dim, it indicates the battery has been discharged. Give refresh charge for 5 to 10 hours with charge current shown in the specification (see Specifications).
When a fast charge is inevitably required, do it following precisely the maximum charge current and time conditions indicated on the battery.

NOTICE

This battery is designed to sustain no unusual deterioration if refresh-charged according to the method specified above. However, the battery's performance may be reduced noticeably if charged under conditions other than given above.

Never remove the seal caps during refresh charge.

If by chance an excessive amount of gas is generated due to overcharging, the relief valve releases the gas to keep the battery normal.

- 3) When you do not use the motorcycle for months
Give a refresh charge before you store the motorcycle and store it with the negative lead removed. Give a refresh charge once a month during storage.
- 4) Battery life
If the battery will not start the engine even after several refresh charges, the battery has exceeded its useful life. Replace it. (Provided, however, the vehicle's starting system has no problem.)

⚠ DANGER

Batteries produce an explosive gas mixture of hydrogen and oxygen that can cause serious injury and burns if ignited. Keep the battery away from sparks and open flames during charging. When using a battery charger, connect the battery to the charger before turning on the charger. This procedure prevents sparks at the battery terminals which could ignite any battery gases. The electrolyte contains sulfuric acid. Be careful not to have it touch your skin or eyes. If touched, wash it off with liberal amount of water and seek medial attention for more severe burns.

Battery

Interchange

A sealed battery can fully display its performance only when combined with a proper vehicle electric system. Therefore, replace a sealed battery only on a vehicle which was originally equipped with a sealed battery.

Be careful, if a sealed battery is installed on a vehicle which had an ordinary battery as original equipment, the sealed battery's life will be shortened.

Charging Condition Inspection

Battery charging condition can be checked by measuring battery terminal voltage with a digital voltmeter [A].

- Remove the battery (see Battery Removal).

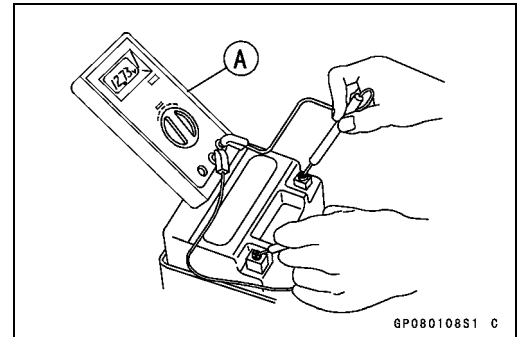

NOTICE

Be sure to disconnect the negative (-) lead first.

- Measure the battery terminal voltage.

NOTE

○ Measure with a digital voltmeter which can be read to one decimal place voltage.

- ★ If the reading is 12.6 V or more, no refresh charge is required, however, if the reading is below the specified, refresh charge is required.

Battery Terminal Voltage

Standard: 12.6 V or more

Terminal Voltage (V) [A]

Battery Charge Rate (%) [B]

Refresh charge is required [C]

Good [D]

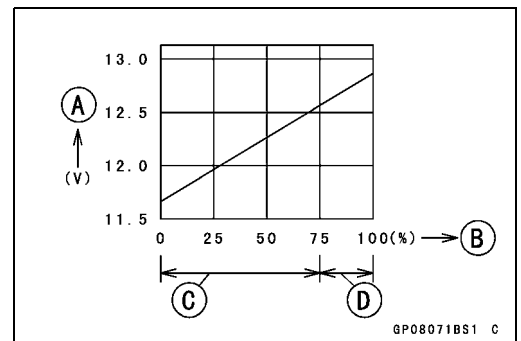

Refreshing Charge

- Remove the battery [A] (see Battery Removal).
- Refresh-charge by following method according to the battery terminal voltage.

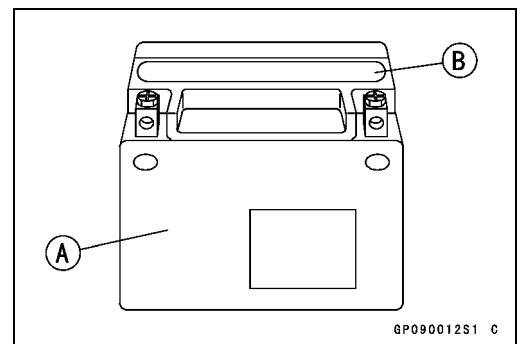

WARNING

This battery is sealed type. Never remove seal sheet [B] even at charging. Never add water. Charge with current and time as stated below.

Terminal Voltage: 11.5 ~ less than 12.6 V

Standard Charge

0.7 A × 5 ~ 10 h (see following chart)

Quick Charge

3.0 A × 1.0 h

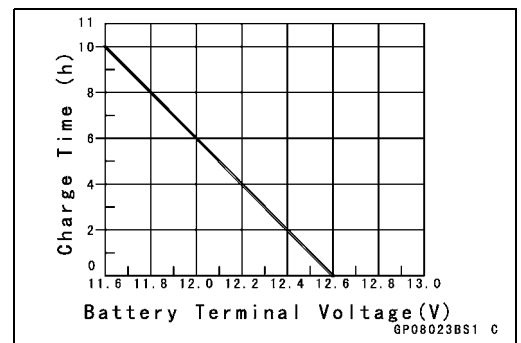

NOTICE

If possible, do not quick charge. If the quick charge is done unavoidably, do the standard charge later on.

Terminal Voltage: less than 11.5 V

Charging Method: 0.7 A × 20 h

16-30 ELECTRICAL SYSTEM

Battery

NOTE

○ Increase the charging voltage to a maximum voltage of 25 V if the battery will not accept current initially. Charge for no more than 5 minutes at the increased voltage then check if the battery is drawing current. If the battery will accept current decrease the voltage and charge by the standard charging method described on the battery case. If the battery will not accept current after 5 minutes, replace the battery.

- Battery [A]
- Battery Charger [B]
- Standard Value [C]
- Current starts to flow [D]

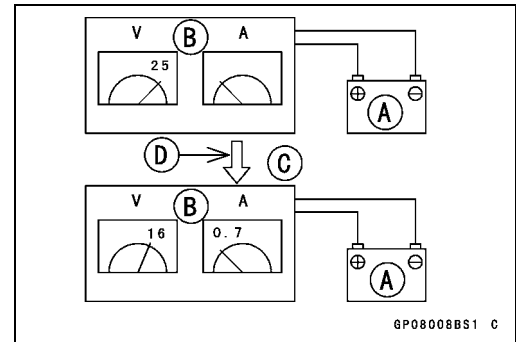

- Determine battery condition after refreshing charge.
- Determine the condition of the battery 30 minutes after completion of the charge by measuring the terminal voltage according to the table below.

Criteria	Judgement
12.6 V or higher	Good
12.0 ~ lower than 12.6 V	Charge insufficient → Recharge
lower than 12.0 V	Unserviceable → Replace

Charging System

Alternator Cover Removal

- Remove:
 - Seat (see Seat Removal in the Frame chapter)
 - Bolts [A]
 - Vehicle-down Sensor Bracket [B]

- Remove:
 - Bands [A]
- Disconnect the crankshaft sensor connector [B] and alternator connector [C].

- Remove:
 - Engine Sprocket Cover (see Engine Sprocket Removal in the Final Drive chapter)
 - Torque Limiter (see Torque Limiter Removal in the Crankshaft/Transmission chapter)
 - Bolt [A]
 - Neutral Switch Lead Retaining Plate [B]
 - Neutral Switch Connector [C]

- Remove:
 - Regulator/Rectifier Connector [A]
 - Oil Pipe Banjo Bolts [B]
- Draw out the harness [C] forward.

- Unscrew the bolts [A] and remove the alternator cover [B].

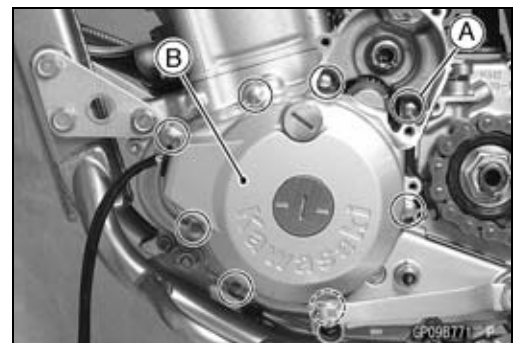
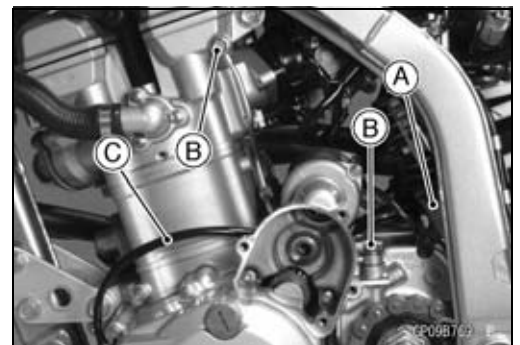
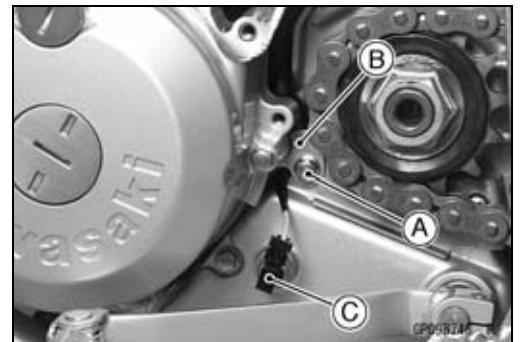
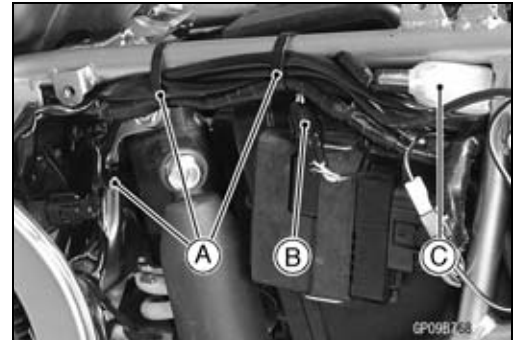
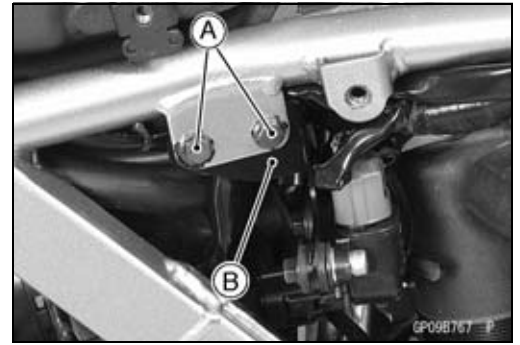

16-32 ELECTRICAL SYSTEM

Charging System

Alternator Cover Installation

- Install the dowel pins [A] into the crankcase.
- Replace the gasket [B] with a new one.

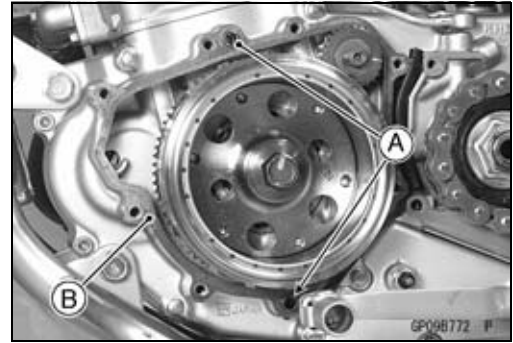

- Apply silicone sealant to the crankshaft sensor and stator coil leads grommet [A].

Sealant - Liquid Gasket, TB1211F: 92104-0004

- Tighten:

Torque - Alternator Cover Bolts: 9.8 N·m (1.0 kgf·m, 87 in·lb)

- Apply grease to the neutral switch terminal.

- Tighten:

Torque - Oil Pipe Banjo Bolt (M8): 9.8 N·m (1.0 kgf·m, 87 in·lb)

- Connect the crankshaft sensor, stator coil, regulator/rectifier and neutral switch lead connector.

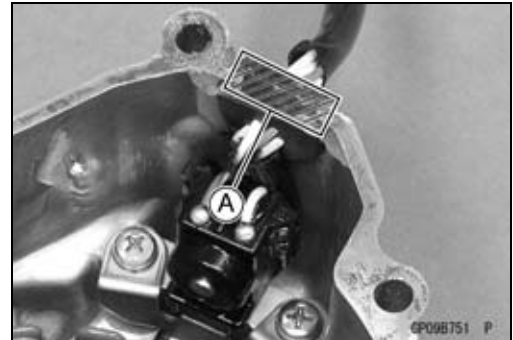

Alternator Rotor Removal

- Remove the alternator cover (see Alternator Cover Removal).
- Hold the alternator rotor [A] steady with the rotor holder [B], and remove the rotor bolt [C].

Special Tools - Grip [D]: 57001-1519

Rotor Holder: 57001-1723

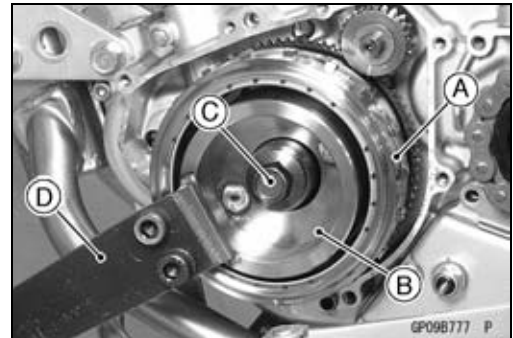

- Using the rotor puller [A], remove the alternator rotor.

Special Tool - Rotor Puller, M16/M18/M20/M22 × 1.5: 57001-1216

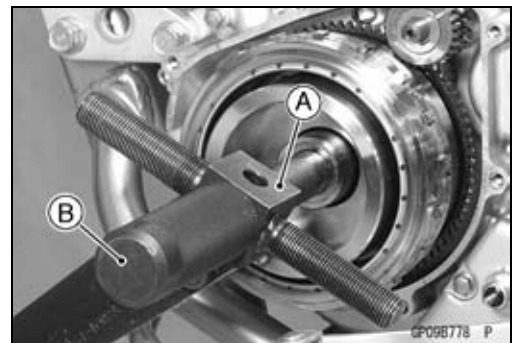

NOTICE

If the rotor is difficult to remove, turn the puller shaft using a wrench while tapping the head [B] of the puller shaft with a hammer. Do not attempt to strike the grab bar or the alternator rotor itself. Striking the bar or the rotor can cause the bar to bend or the magnets to lose their magnetism.

Charging System

- Remove:
 - Idle Gear [A]
 - Starter Motor Clutch Gear [B]



Alternator Rotor Installation

- Install the collar [A] so that the small outside diameter faces outward.

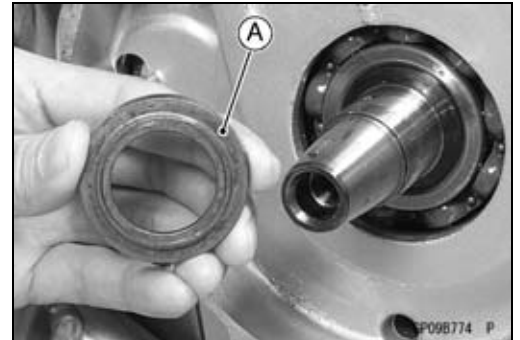

- Install:
 - Starter Motor Clutch Gear [A]
 - Idle Gear [B]
 - Spacer [C]



- Using a cleaning fluid, clean off any oil or dirt on the following portions and dry them with a clean cloth.
 - Crankshaft Tapered Portion [A]
 - Alternator Rotor Tapered Portion [B]
- Install the woodruff key [C] into the slot of the crankshaft securely.
- Fit the groove [D] on the woodruff key.

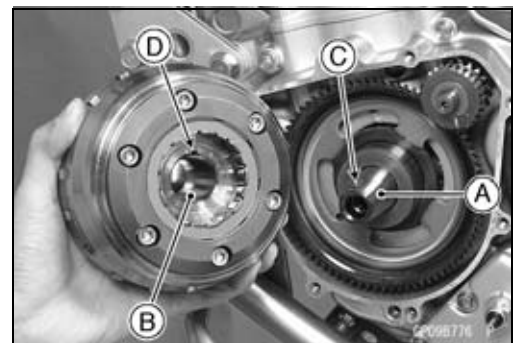

- While turning the starter motor clutch gear [A] clockwise [B], install the alternator rotor [C].
- Apply molybdenum disulfide oil to the threads of the alternator rotor bolt.
- Tighten the rotor bolt while holding the alternator rotor steady with the rotor holder.

Special Tools - Grip [D]: 57001-1519

Rotor Holder: 57001-1723

Torque - Alternator Rotor Bolt: 120 N·m (12.2 kgf·m, 88.5 ft·lb)

- Install the alternator cover (see Alternator Cover Installation).



16-34 ELECTRICAL SYSTEM

Charging System

Stator Coil Removal

- Remove:
 - Alternator Cover (see Alternator Cover Removal)
 - Stator Coil Bolts [A]
 - Crankshaft Sensor Screws [B]
 - Stator Coil Lead Holder [C]
 - Grommet [D]
- Remove the stator coil [E] and crankshaft sensor [F] as a set.

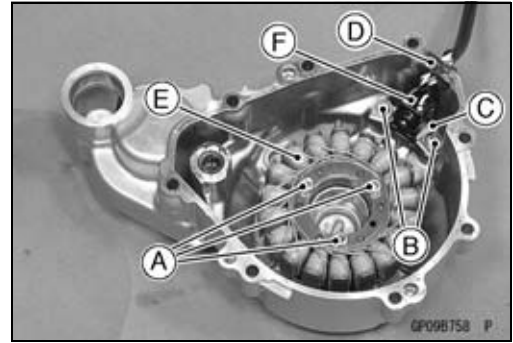

Stator Coil Installation

- Install the stator coil, and tighten the bolts [A].
 - Torque - Stator Coil Bolts: 5.9 N·m (0.60 kgf·m, 52 in·lb)**
- Install the crankshaft sensor [B] and holder [C].
- Run the stator coil and crankshaft sensor leads under the holder and crankshaft sensor.
 - Torque - Crankshaft Sensor Screws: 2.4 N·m (0.24 kgf·m, 21 in·lb)**
- Apply silicone sealant to the circumference of the grommet [D].
- Sealant - Liquid Gasket, TB1211F: 92104-0004**
- Set the grommet securely in the notch [E].
- Install the alternator cover (see Alternator Cover Installation).

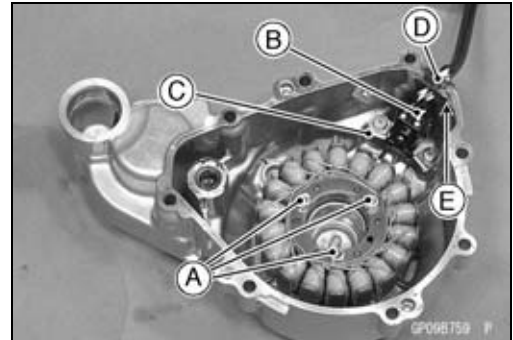

Alternator Inspection

There are three types of alternator failures: short, open (wire burned out), or loss in rotor magnetism. A short or open in one of the stator coil leads will result in either a low output, or no output at all. A loss in rotor magnetism, which may be caused by dropping or hitting the alternator, by leaving it near an electromagnetic field, or just by aging, will result in low output.

- To check the alternator output voltage, do the following procedures.
 - Disconnect the regulator/rectifier connector [A].
 - Connect a hand tester to the connector as shown.

Special Tool - Hand Tester: 57001-1394

- Start the engine.
- Run it at 4 000 rpm.
- Note the voltage readings.

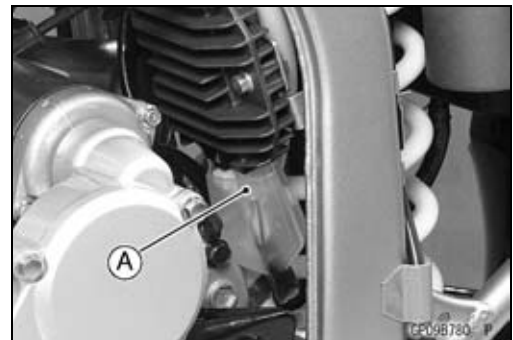

Charging System

Alternator Output Voltage

Tester Range	Connections		Standard @4 000 rpm
	Tester (+) Lead Connection	Tester (-) Lead Connection	
AC 250 V	One Yellow Lead	Another Yellow Lead	45 V or more

○ Repeat testing other yellow leads.

Hand Tester [A]

★ If the output voltage shows the value in the table, the alternator operates properly.

★ If the output voltage shows a much higher than the value in the table, the regulator/rectifier is damaged. A much lower reading than that given in the table indicates that the alternator is defective.

● Check the stator coil resistance as follows.

○ Stop the engine.

○ Connect the hand tester [A] to the connector as shown in the table.

○ Note the resistance readings.

Stator Coil Resistance

Tester Range	Connections		Standard
	Tester (+) Lead Connection	Tester (-) Lead Connection	
$\times 1 \Omega$	One Yellow Lead	Another Yellow Lead	0.3 ~ 1.0 Ω

○ Repeat testing other yellow leads.

★ If there is more resistance than shown in the table, or no hand tester reading (infinity) for any two leads, the stator coil has an open lead and must be replaced. Much less than this resistance means the stator coil is shorted, and must be replaced.

○ Using the highest resistance range of the hand tester, measure the resistance between each of the Yellow leads and chassis ground.

★ Any hand tester reading less than infinity (∞) indicates a short, necessitating stator coil replacement.

★ If the stator coil has normal resistance, but the voltage check showed the alternator to be defective, then the rotor magnets have probably weakened, and the rotor must be replaced.

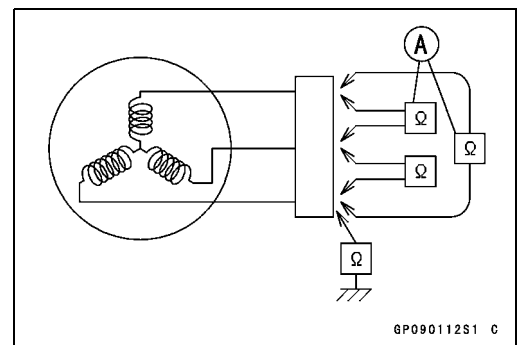
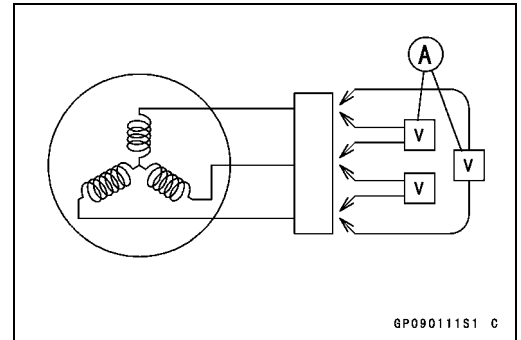

16-36 ELECTRICAL SYSTEM

Charging System

Regulator/Rectifier Removal

- Remove the regulator/rectifier connector [A].
- Remove the bolts [B], and then remove the regulator/rectifier [C].

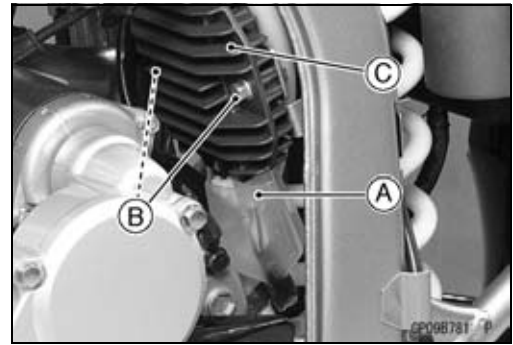

Regulator/Rectifier Installation

- Install:
 - Regulator/Rectifier
- Tighten:
 - Torque - Regulator/Rectifier Mounting Bolts: 9.8 N·m (1.0 kgf·m, 87 in·lb)**
- Connect the regulator/rectifier connector.

Charging Voltage Inspection

- Check the battery condition (see Charging Condition Inspection).
- Warm the engine up.
- Stop the engine, and remove the left side cover (see Side Cover Removal in the Frame chapter).
- Set the hand tester to the DC 25 V range and connect it in the table.

Special Tool - Hand Tester: 57001-1394

Charging Voltage

Tester Range	Connections		Standard @4 000 rpm
	Tester (+) Lead Connection	Tester (-) Lead Connection	
DC 25 V	Battery (+) Terminal	Battery (-) Terminal	14.2 ~ 15.2 V



- Start the engine, and note the voltage readings at various engine speeds with the headlight turned on and then turned off. While the engine speed is low, a measured value is nearly the same with the battery voltage. A greater measured value will be obtained with the increase of the engine speed. Nevertheless, no measured values will exceed the upper limit specified in the table.
- Turn off the ignition switch to stop the engine, and disconnect the hand tester.
- ★ If the reading is within range, the charging system is considered to be working normally.
- ★ If the reading shows a much higher than the upper value in the table, the regulator/rectifier is damaged, or the leads are loose or open.
- ★ If the voltage does not rise as the engine speed increases, then the regulator/rectifier is defective or the alternator output is insufficient for the loads. Check the relevant parts of the alternator and the regulator/rectifier.

Charging System

Regulator/Rectifier Inspection

- Remove the regulator/rectifier (see regulator/rectifier Removal).

Rectifier Circuit Check

- Check conductivity of the following pair of terminals.

Rectifier Circuit Inspection

Tester connection	W-Y1,	W-Y2,	W-Y3
	BK/Y-Y1,	BK/Y-Y2,	BK/Y-Y3,

- ★ The resistance should be low in one direction and more than ten times as much in the other direction. If any two leads are low or high in both directions, the rectifier is defective and the regulator/rectifier must be replaced.

NOTE

- The actual meter reading varies with the meter used and the individual rectifier, but, generally speaking the lower reading should be from zero to one half the scale.

Regulator Circuit Check

To test the regulator out of circuit, use three 12 V batteries and a test light (12 V 3 ~ 6 W bulb in a socket with leads).

NOTICE

The test light works as an indicator and also a current limiter to protect the regulator/rectifier from excessive current. Do not use an ammeter instead of a test light.

- Check to be sure the rectifier circuit is normal before continuing.
- Do the 1st step regulator circuit test.
 - Connect the test light and the 12 V battery to the regulator/rectifier as shown.
 - Check the Y1, Y2 and Y3 terminal respectively.
 - ★ If the test light turns on, the regulator/rectifier is defective. Replace it.
 - ★ If the test light does not turn on, continue the test.
- Do the 2nd step regulator circuit test.
 - Connect the test light and the 12 V battery in the same manner as specified in the "Regulator Circuit Test-1st Step".
 - Apply 12 V to the voltage BR terminal.
 - Check the Y1, Y2 and Y3 terminal respectively.
 - ★ If the test light turns on, the regulator/rectifier is defective. Replace it.
 - ★ If the test light does not turn on, continue the test.

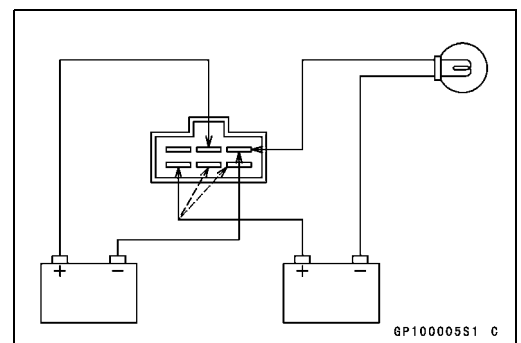
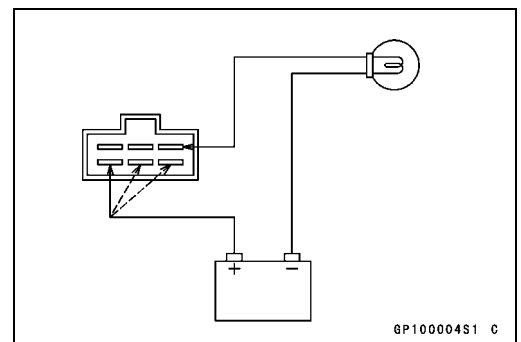
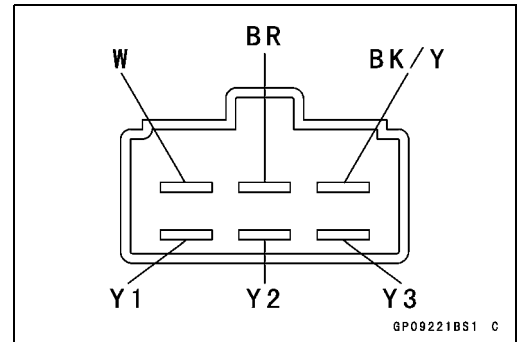

16-38 ELECTRICAL SYSTEM

Charging System

- Do the 3rd step regulator circuit test.
- Connect the test light and the 12 V battery in the same manner as specified in the “Regulator Circuit Test-1st Step”.
- Momentarily apply 24 V to the voltage BR terminal by adding a 12 V battery.
- Check the Y1, Y2 and Y3 terminals respectively.

NOTICE

Do not apply more than 24 V. If more than 24 V is applied, the regulator/rectifier may be damaged. Do not apply 24 V more than a few seconds. If 24 V is applied for more than a few seconds, the regulator/rectifier may be damaged.

- ★ If the test light did not light when the 24 V was applied momentarily to the voltage monitoring terminal, the regulator/rectifier is defective. Replace it.
 - ★ If the regulator/rectifier passes all of the tests described, it may still be defective. If the charging system still does not work properly after checking all of the components and the battery, test the regulator/rectifier by replacing it with a known good unit.
- Connect the hand tester to the regulator/rectifier.

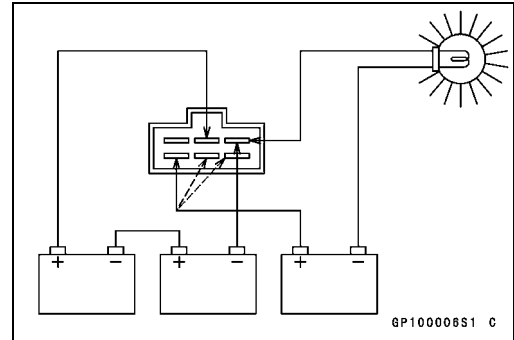

Charging System

Charging System Circuit

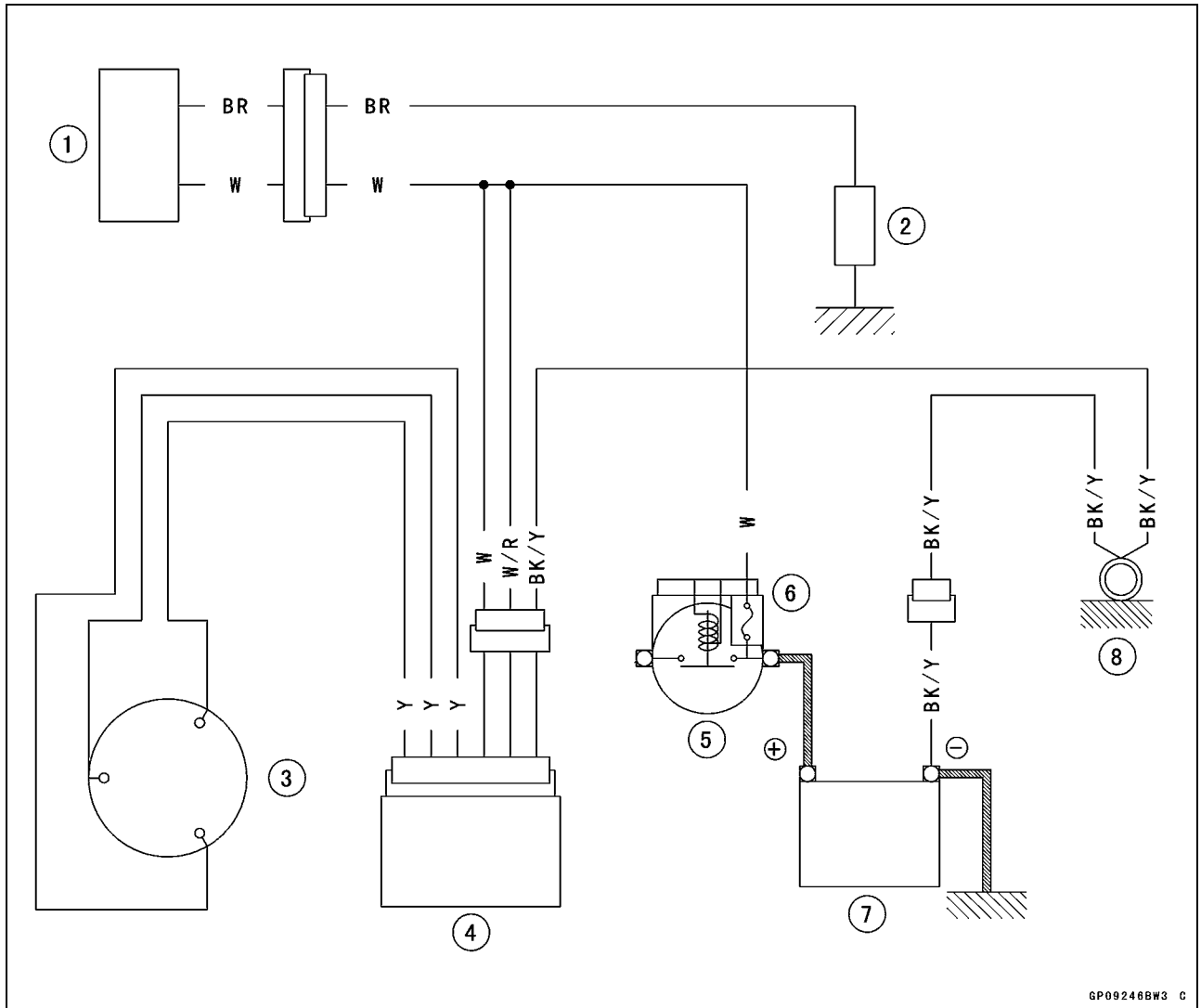

GP09246BW3 C

1. Ignition Switch
2. Load
3. Alternator
4. Regulator/Rectifier
5. Starter Relay
6. Main Fuse 20 A
7. Battery 12 V 6 Ah
8. Frame Ground

16-40 ELECTRICAL SYSTEM

Ignition System

Ignition Timing Inspection

- Remove the timing inspection cap [A].
Special Tool - Filler Cap Driver: 57001-1454

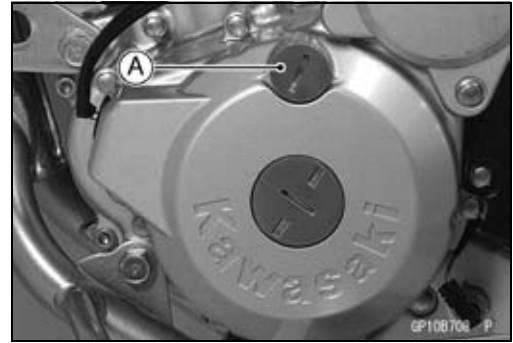

- Attach the timing light [A] to the ignition coil lead in the manner prescribed by the manufacturer.

Special Tool - Timing Light: 57001-1241

- Start the engine and aim the timing light at the ignition timing mark on the alternator rotor.

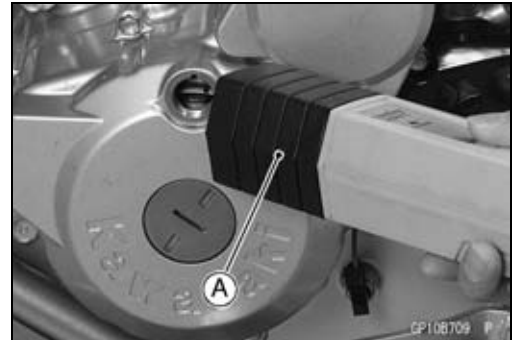

- Run the engine at the speeds specified and note the alignment of the ignition timing mark.

Ignition Timing

Engine speed [r/min (rpm)]	Hole groove [A] aligns with:
Idle Speed to 1 300	F mark [B] on alternator rotor

- ★ If the ignition timing is incorrect, check the crankshaft sensor (see Crankshaft Sensor Inspection).
- ★ If the crankshaft sensor are normal, check the igniter (see Igniter Inspection).
- Install the timing inspection cap.

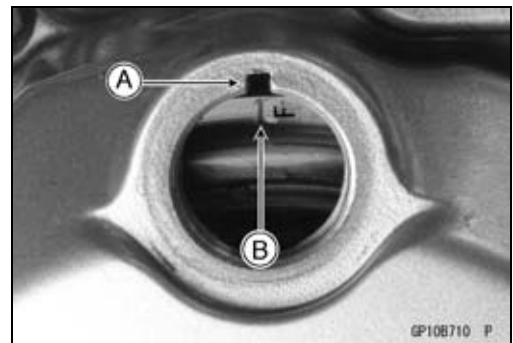

⚠ WARNING

The ignition system produces extremely high voltage. Do not touch the spark plug while the engine is running, or you could receive a severe electrical shock.

NOTICE

Do not disconnect the battery cables or any other electrical connections when the ignition switch is on, or while the engine is running. This is to prevent igniter damage.

Do not install the battery backwards. The negative side is grounded. This is to prevent damage to the diodes and igniter.

Use the standard regulator/rectifier, or the igniter will be damaged.

Crankshaft Sensor Removal

- Refer to the Stator Coil Removal.

Crankshaft Sensor Installation

- Refer to the Stator Coil Installation.

Ignition System

Crankshaft Sensor Inspection

- Remove the left side cover (see Left Side Cover Removal in the Frame chapter).
- Disconnect the crankshaft sensor lead connector.
- Set the hand tester [A] to the $\times 100 \Omega$ range and connect it to the crankshaft sensor lead connector [B].

Special Tool - Hand Tester: 57001-1394

Crankshaft Sensor Resistance

Connections: G/W Lead \longleftrightarrow W/Y Lead

Standard: Approx. 240Ω @20°C (68°F)

- ★ If there is more resistance than the specified value, the coil has an open lead and must be replaced. Much less than this resistance means the coil is shorted, and must be replaced.
- Using the highest resistance range of the tester, measure the resistance between the crankshaft sensor leads and chassis ground.
- ★ Any tester reading less than infinity (∞) indicates a short, necessitating replacement of the crankshaft sensor assembly.

Crankshaft Sensor Peak Voltage Inspection

- Remove the left side cover (see Side Cover Removal in the Frame chapter).
- Pull off the spark plug cap from the spark plug (see Ignition Coil Removal).
- Do not remove the spark plug.

NOTE

○ Using the peak voltage adapter is more reliable way to determine the condition of the crankshaft sensor than crankshaft sensor internal resistance measurements.

- Set the hand tester to the \times DC 10 V range, and connect it peak voltage adapter [A].

Special Tools - Hand Tester: 57001-1394

Peak Voltage Adapter: 57001-1415

Type: KEK-54-9-B

Needle Adapter Set: 57001-1457

- Connect the adapter to the terminals of the crankshaft sensor connector [B].

Connections:

Adapter (R, +) \rightarrow **G/W Lead**

Adapter (BK, -) \rightarrow **W/Y Lead**

- Pushing the starter button, turn the engine 4 ~ 5 seconds with the transmission in neutral to measure the primary peak voltage.

Crankshaft Sensor Peak Voltage

Standard: **3.7 V or more**

- ★ If the reading is less than the standard, check the crankshaft sensor (see Crankshaft Sensor Inspection).

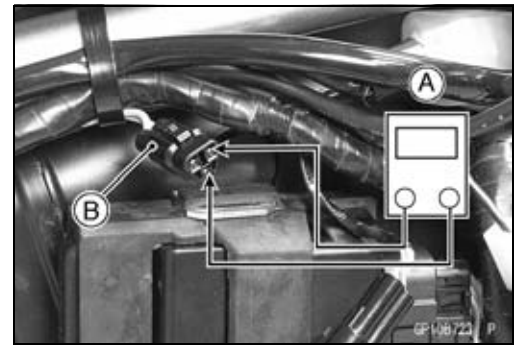

16-42 ELECTRICAL SYSTEM

Ignition System

Ignition Coil Removal

- Remove:
 - Fuel Tank (see Fuel Tank Removal in the Fuel System (DFI) chapter)
- Pull off the spark plug cap [A] from the spark plug.

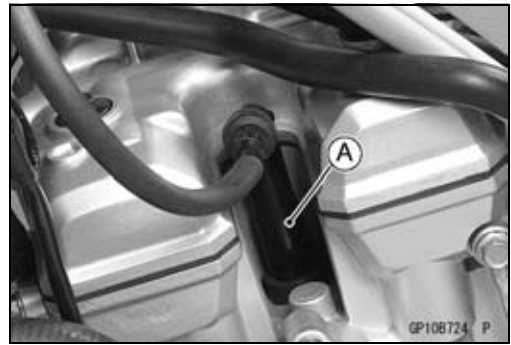

- Remove:
 - Ignition Coil Bolts [A]
 - Ignition Coil [B]

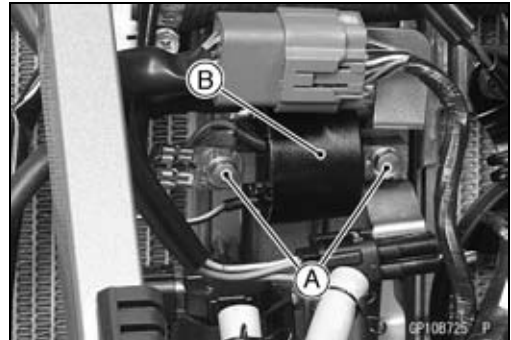

- Disconnect the ignition coil primary connector [A].



Ignition Coil Installation

- Connect the primary lead connector [A].
- Set the ignition coil ground lead terminal [B] first, and install the ground terminal [C].
- Tighten:

Torque - Ignition Coil Mounting Bolts: 9.8 N·m (1.0 kgf·m, 87 in·lb)

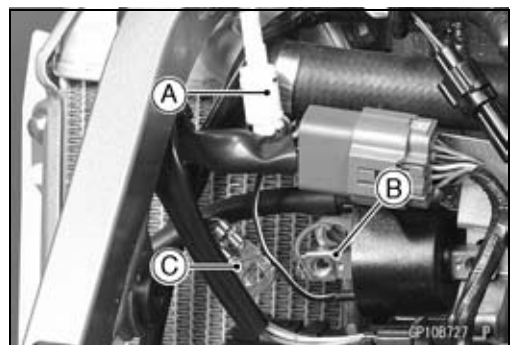

Ignition System

Ignition Coil Inspection

- Remove the ignition coil (see Ignition Coil Removal).
- Measure the arcing distance with a suitable commercially available coil tester [A] to check the condition of the ignition coil [B].
- Connect the ignition coil (with the spark plug cap left attached) to the tester in the manner prescribed by the manufacturer and measure the arcing distance.

Ignition Coil Arcing Distance

6 mm (0.24 in.) or more

⚠ WARNING

To avoid extremely high voltage shocks, do not touch the coil or high tension lead.

- ★ If the distance reading is less than the specified value, the ignition coil or spark plug cap is defective.
- To determine which part is defective, measure the arcing distance again with the spark plug cap removed from the ignition coil.
- ★ If the arcing distance is subnormal as before, the trouble is with the ignition coil itself. If the arcing distance is now normal, the trouble is with the spark plug cap.
- ★ If the arcing tester is not available, the coil can be checked for a broken or badly shorted winding with the hand tester.

NOTE

○ The hand tester can not detect layer shorts and shorts resulting from insulation breakdown under high voltage.

- Measure the primary winding resistance [A] as follows.
- Connect the hand tester between the primary terminals.
- Special Tool - Hand Tester: 57001-1394**
- Set the tester to the $\times 1\Omega$ range, and read the tester.
- Measure the secondary winding resistance [C] as follows:
- Remove the spark plug cap by turning it counterclockwise.
- Connect the hand tester between the spark plug lead and ignition coil negative (-) terminal.
- Set the tester to the $\times 1\text{ k}\Omega$ range, and read the tester.

Ignition Coil [B] Winding Resistance

Primary windings: 0.17 ~ 0.23 Ω @20°C (68°F)

Secondary windings: 5.0 ~ 7.6 k Ω @20°C (68°F)

- ★ If the tester does not read as specified, replace the coil.
- ★ If the tester reads as specified, the ignition coil windings are probably good. However, if the ignition system still does not perform as it should after all other components have been checked, replace the coil with one known to be good.
- Check the spark plug lead for visible damage.
- ★ If the spark plug lead is damaged, replace the coil.
- Before installing the spark plug cap, apply a thin coat of PBC (Poly Butyl Cuprystil) grease to the end of spark plug lead (PBC is a special high-temperature, water-resistance grease).

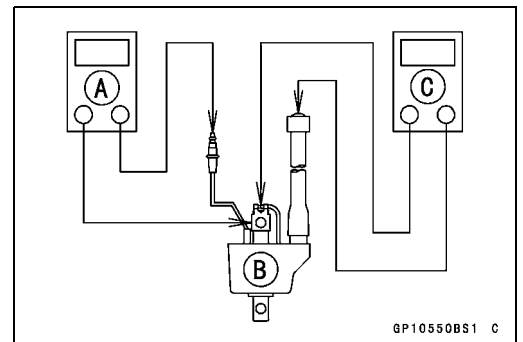
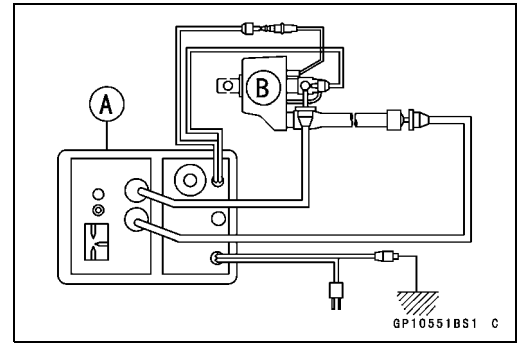

16-44 ELECTRICAL SYSTEM

Ignition System

Ignition Coil Primary Peak Voltage Inspection

NOTE

○Be sure the battery is fully charged.

- Remove:
 - Left Radiator Shroud (see Radiator Shroud Removal in the Frame chapter)
- Pull off the spark plug cap from the spark plug (see Ignition Coil Removal).
- Do not remove the spark plug.
- Measure the primary peak voltage as follows.
- Install the new spark plug [A] into the plug cap, and ground it onto the engine.
- Set the hand tester to the × DC 250 V range. Connect the peak voltage adapter [B] into the hand tester and connect its terminals to the ignition coil [C] lead and ground.

Special Tools - Hand Tester: 57001-1394

Peak Voltage Adapter: 57001-1415

Type: KEK-54-9-B

Needle Adapter Set: 57001-1457

Connections:

- Adapter (R, +) → Ground [D]
- Adapter (BK, -) → BK/W Lead Terminal [E]
- [F] ECU
- [G] Needle Adapter

NOTE

○Measure the voltage with each lead connected correctly. The correct value may not be obtained if disconnected.

⚠ WARNING

To avoid extremely high voltage shocks, do not touch the spark plug or tester connections.

- Turn the engine stop switch to run position.
- Turn the ignition switch ON.
- Pushing the starter button, turn the engine 4 ~ 5 seconds with the transmission in neutral to measure the primary peak voltage.
- Repeat the measurements 5 times or more times.

Ignition Coil Primary Peak Voltage

Standard: 120 V or more

- ★ If the reading is less than the standard, check the ignition coil (see Ignition Coil Inspection).
- ★ If the ignition coil is good, check the other parts (see Ignition System Troubleshooting in this section).

Spark Plug Removal

- Refer to the Spark Plug Replacement in the Periodic Maintenance chapter.

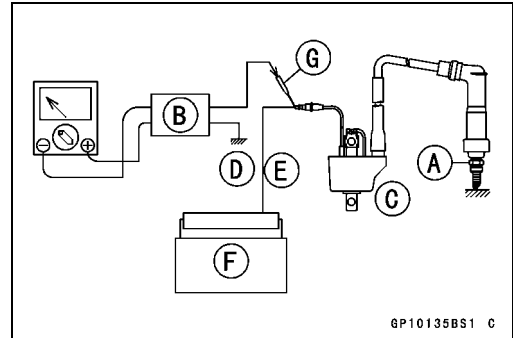
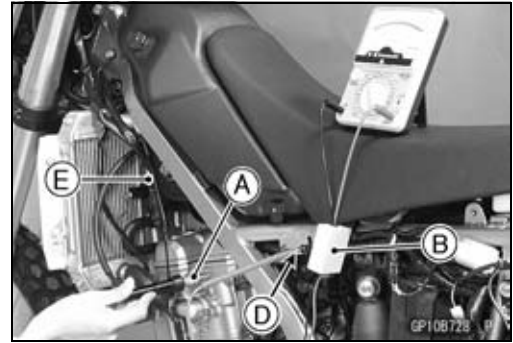

GP10135BS1 C

Ignition System

Spark Plug Installation

- Refer to the Spark Plug Replacement in the Periodic Maintenance chapter.

Spark Plug Cleaning and Inspection

- Remove the spark plug (see Spark Plug Replacement in the Periodic Maintenance chapter).
- Clean the spark plug, preferably in a sandblasting device, and then clean off any abrasive particles. The plug may also be cleaned using a high-flash point solvent and a wire brush or other tool.
- ★ If the spark plug center electrode [A] and/or side electrode [B] are corroded or damaged, or if the insulator [C] is cracked, replace the plug.
- Use the standard spark plug or its equivalent.

Spark Plug: **NGK CR8E or**
 ND U24ESR-N

- Measure the gap [D] with a wire-type thickness gauge.
- ★ If the gap is incorrect, carefully bend the side electrode with a tool to obtain the correct gap.

Spark Plug Gap: **0.7 ~ 0.8 mm (0.028 ~ 0.031 in.)**

Interlock Operation Inspection

- Raise the rear wheel off the ground with jack.

Special Tool - Jack: 57001-1238

1st Check

- Start the engine to the following conditions.

Condition

Transmission Gear → 1st Position

Clutch Lever → Release

Sidestand → Down or Up

- Turn the ignition switch ON and push the starter button.
- Then the starter motor should not turn when the starter system circuit is normality.
- ★ If the engine is start, inspect the starter lockout switch, neutral switch, sidestand switch and interlock diode unit.
- ★ If their parts are normality replace the ECU.

2nd Check

- Start the engine to the following conditions.

Condition

Transmission Gear → 1st Position

Clutch Lever → Pulled in

Sidestand → Up

- Turn the ignition switch ON and push the starter button.
- Then the starter motor should turn when the starter system circuit is normality.
- ★ If the starter motor is not turn, inspect the starter lockout switch, neutral switch, sidestand switch and interlock diode unit.
- ★ If their parts are normality replace the ECU.

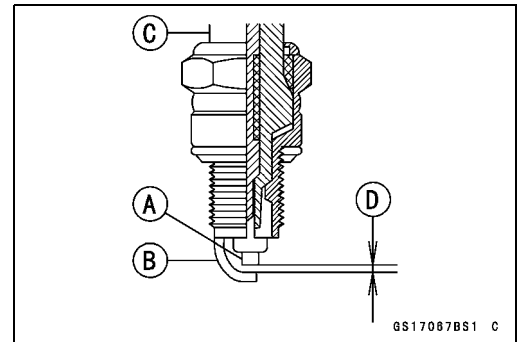

16-46 ELECTRICAL SYSTEM

Ignition System

3rd Check

- Inspect the engine for its secure stop after the following operations are completed.
- Run the engine to the following conditions.

Condition

Transmission Gear → 1st Position

Clutch Lever → Pulled in

Sidestand → Up

- Set the sidestand on the ground, then the engine will stop.
- ★ If whichever may not be stopped, inspect the neutral switch, starter lockout switch, sidestand switch and interlock diode unit.
- ★ If their parts are normality, replace the ECU.

Interlock Diode Unit Inspection

- Remove:
 - Seat (see Seat Removal in the Frame chapter)
 - Interlock Diode Unit [A]



- Set the hand tester to the $\times 10 \Omega$ or $\times 100 \Omega$ range and connect it to the diode unit terminals to check the resistance in both directions.

Special Tool - Hand Tester: 57001-1394

- ★ The resistance should be low in one direction and more than ten times as much in the other direction. If any diode shows low or high in both directions, the diode is defective and the diode unit must be replaced.

NOTE

○ The actual meter reading varies with the meter used and the individual diode, but, generally speaking, the lower reading should be from the zero to one half the scale.

IC Igniter Inspection

- The IC igniter is built in the ECU [A].
- Refer to the following items.
 - Interlock Operation Inspection (see Interlock Operation Inspection)
 - Ignition System Troubleshooting (see Ignition System section)
 - ECU Power Supply Inspection (see ECU Power Supply Inspection in the Fuel System (DFI) chapter)

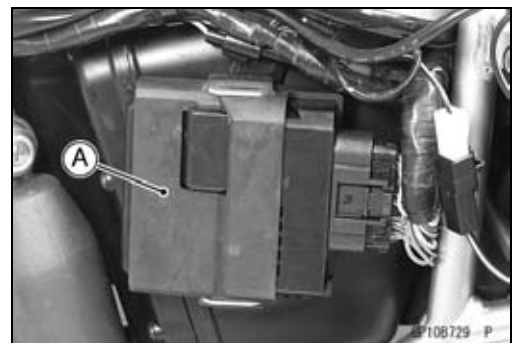
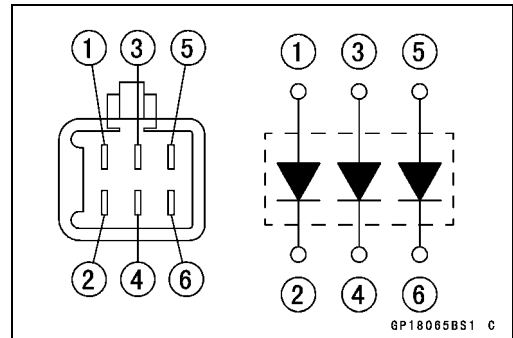

Ignition System

Ignition System Troubleshooting

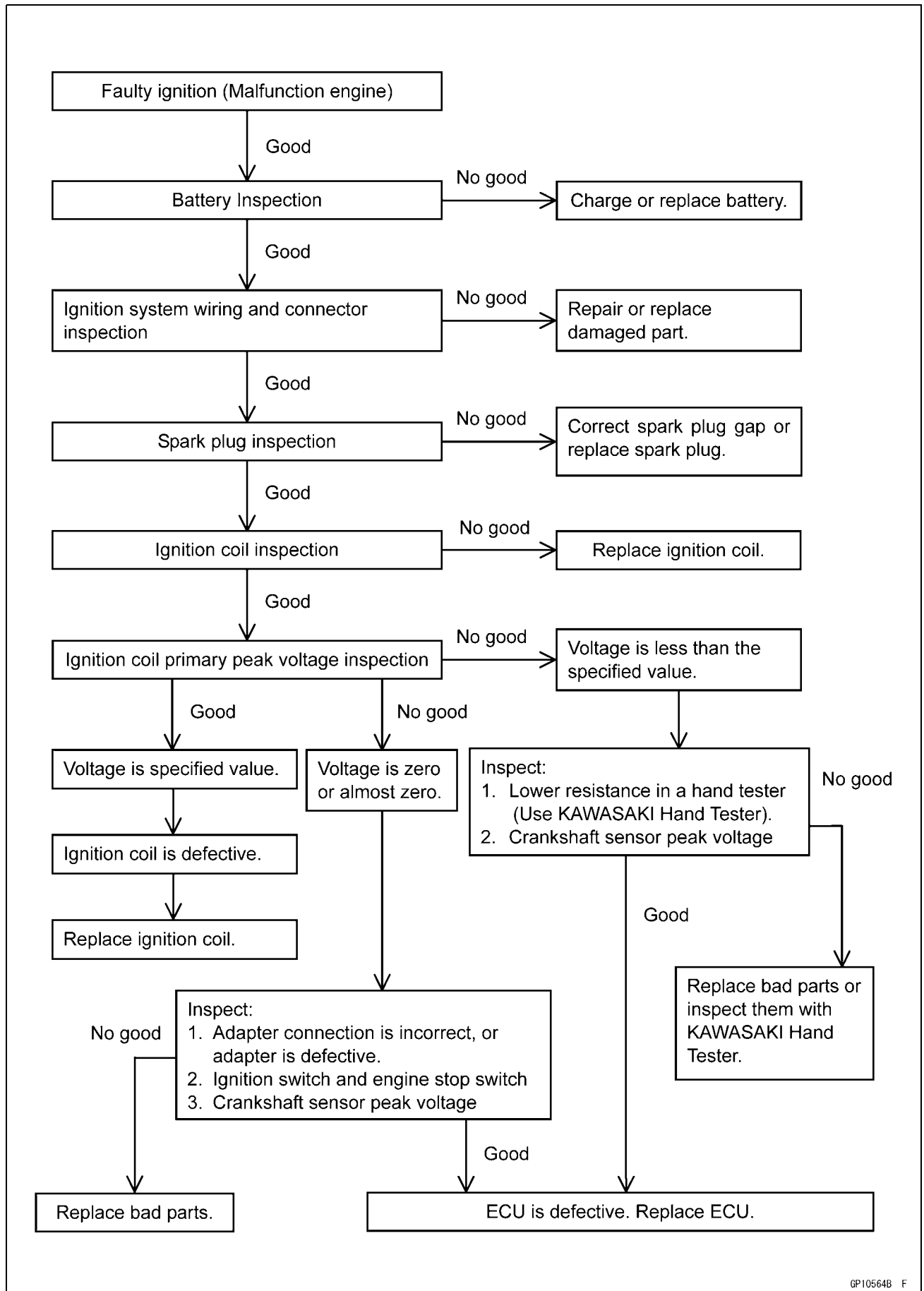

16-48 ELECTRICAL SYSTEM

Ignition System

Ignition System Circuit

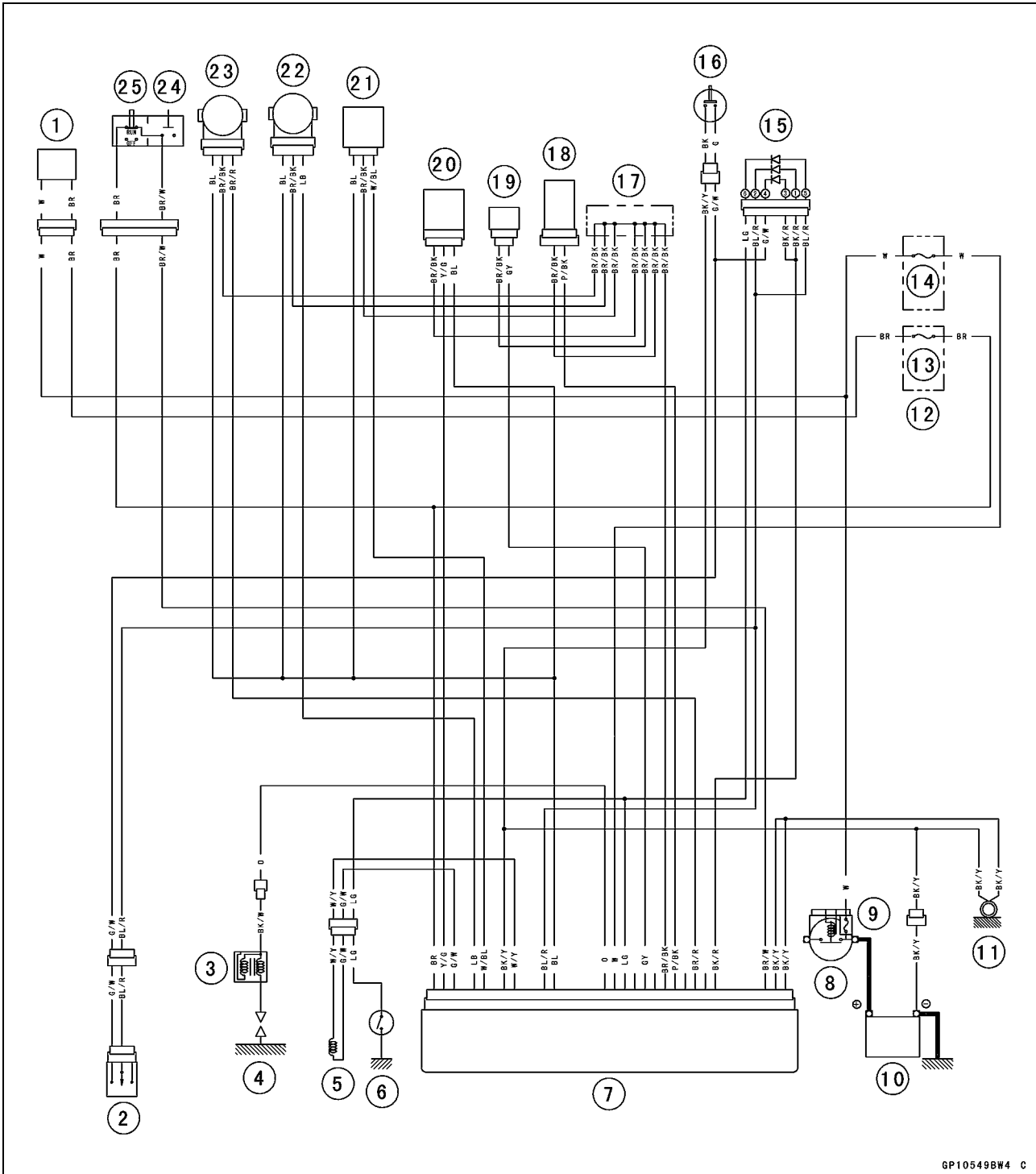

GP10549BW4 C

- 1. Ignition Switch
- 2. Starter Lockout Switch
- 3. Ignition Coil
- 4. Spark Plug
- 5. Crankshaft Sensor
- 6. Neutral Switch
- 7. ECU
- 8. Starter Relay
- 9. Main Fuse 20 A
- 10. Battery 12 V 6 Ah
- 11. Frame Ground
- 12. Fuse Box
- 13. Ignition Fuse 10 A
- 14. ECU Fuse 15 A
- 15. Interlock Diode Unit
- 16. Sidestand Switch
- 17. Water-proof Joint
- 18. Inlet Air Temperature Sensor
- 19. Water Temperature Sensor
- 20. Vehicle-down Sensor
- 21. Inlet Air Pressure Sensor
- 22. Main Throttle Sensor
- 23. Subthrottle Sensor
- 24. Starter Button
- 25. Engine Stop Switch

Starter Motor

Starter Motor Removal

NOTICE

Do not tap the starter motor shaft or body. Tapping the shaft or body could damage the motor.

- Remove:
 - Left Radiator Shroud (see Radiator Shroud Removal in the Frame chapter)
 - Torque Limiter (see Torque Limiter Removal in the Crankshaft/Transmission chapter)
- Remove:
 - Bolts [A]
 - Exhaust Pipe Cover [B]

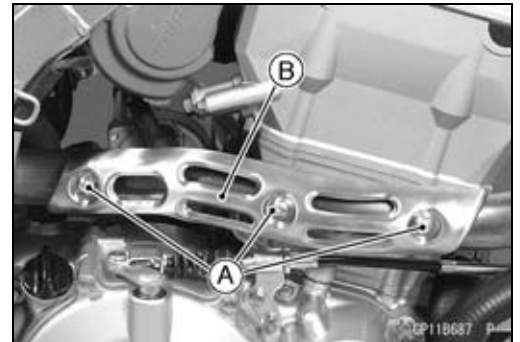

- Slide back the rubber cap [A].
- Remove:
 - Starter Motor Cable Nut [B] and Starter Motor Cable
 - Starter Motor Mounting Bolts [C]
- Pull out the starter motor to the right side.

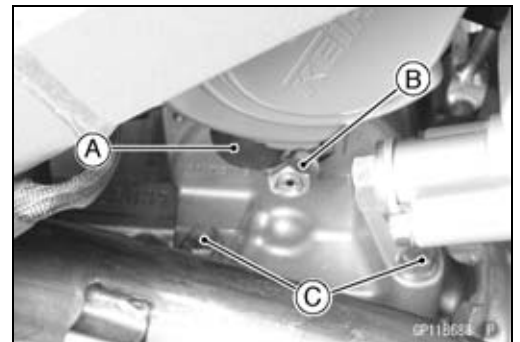

- Turn over the starter motor [A] as shown to remove it from the engine left side.

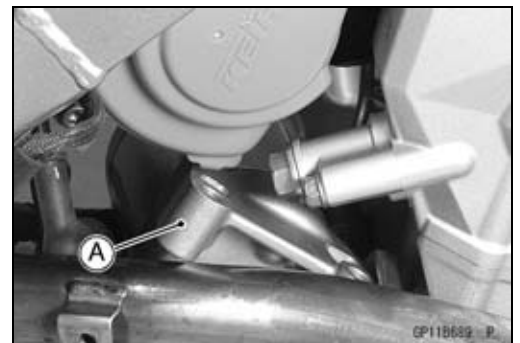

Starter Motor Installation

NOTICE

Do not tap the starter motor shaft or body. Tapping the shaft or body could damage the motor.

- When installing the starter motor, clean the starter motor legs [A] and crankcase [B] where the starter motor is grounded.

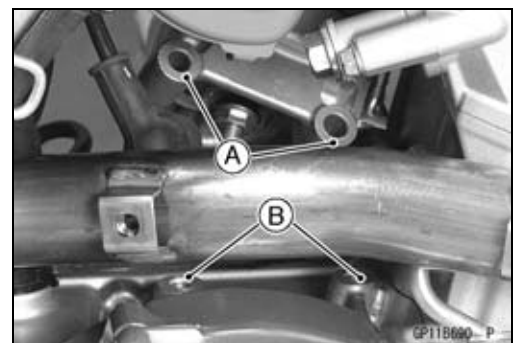

16-50 ELECTRICAL SYSTEM

Starter Motor

- Replace the O-ring [A] with a new one.
- Apply grease to the O-ring.
- Tighten:
Torque - Starter Motor Mounting Bolts: 9.8 N·m (1.0 kgf·m, 87 in·lb)

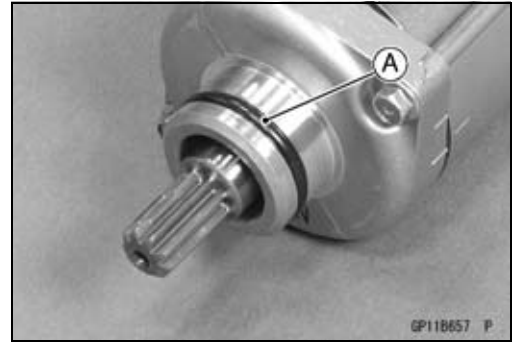

- Position the starter motor cable [A] as shown.
90° [B]
Rear [C]
- Tighten:
Torque - Starter Motor Cable Nut: 9.8 N·m (1.0 kgf·m, 87 in·lb)
- Slide back the rubber cap to the original position.

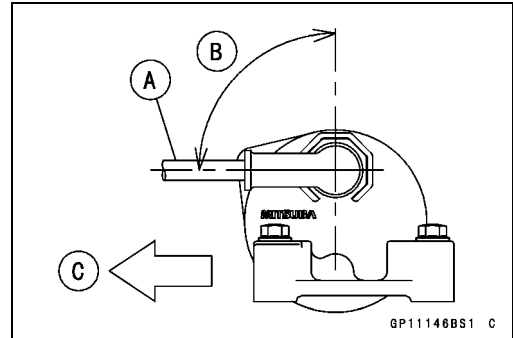

Starter Motor Disassembly

- Remove the starter motor (see Starter Motor Removal).
- Take off the starter motor through bolts [A] and remove the both end covers [B].

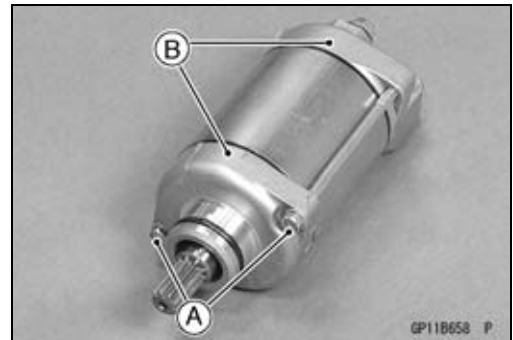

- Pull out the armature [A] out of the yoke [B].

NOTE

○Do not remove the circlip [C] from the shaft.

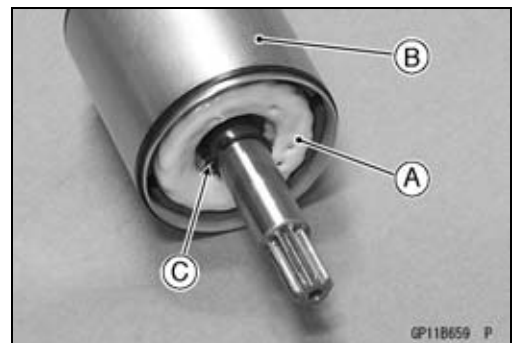

- Remove:
Starter Motor Terminal Locknut [A]
Washer [B]
Collar [C]

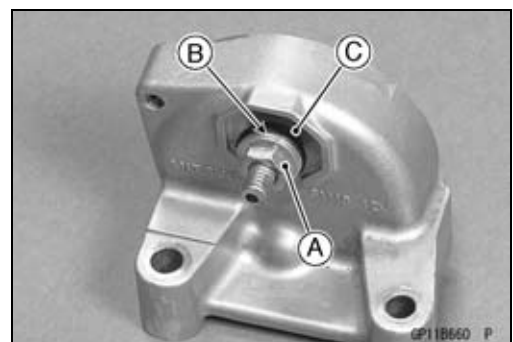

Starter Motor

- Remove:
O-ring [A]

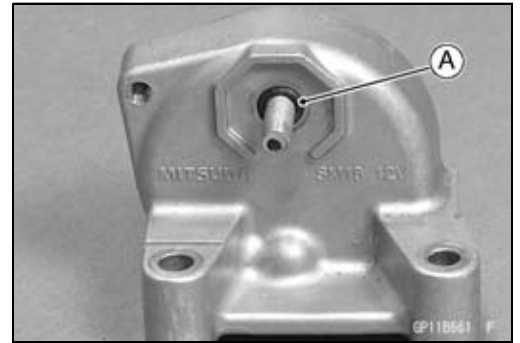

- Pull out the brushes from the brush holder [A].
- Remove:
Brush Springs [B]
Starter Motor Terminal [C]
Positive Brush Assy [D]
Negative Brush Assy Mounting Screw [E]
Negative Brush Assy [F]
Brush Holder

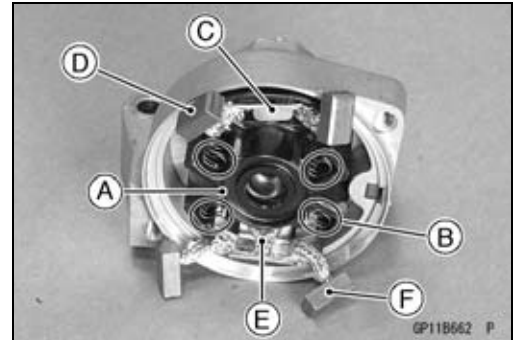

Starter Motor Assembly

- Align the hole [A] of the brush holder [B] to the boss [C] of the right-hand end cover [D].

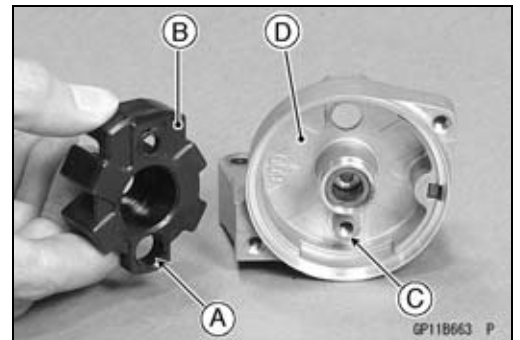

- Align the projections [A] of the negative brush assy [B] to the stoppers [C] of the brush holder [D].
- Tighten the negative brush assy mounting screw.

**Torque - Negative Brush Assy Mounting Screw: 3.8 N·m
(0.39 kgf·m, 34 in·lb)**

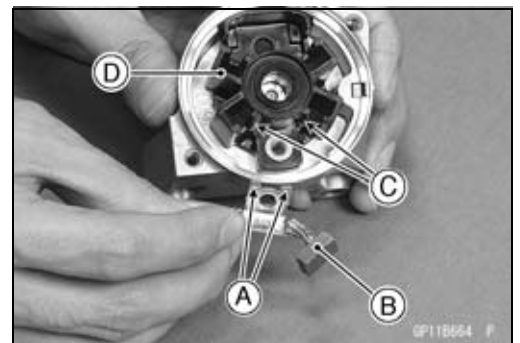

- Align the stoppers [A] of the positive brush assy [B] to the grooves [C] of the brush holder [D].
- Install the starter motor terminal.

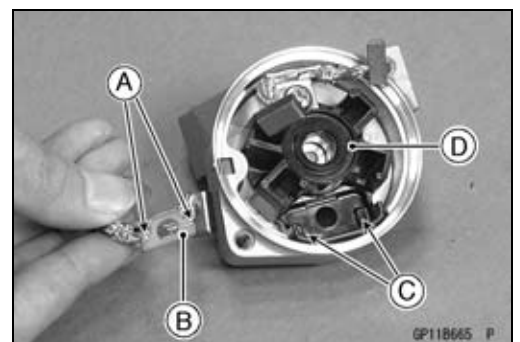

16-52 ELECTRICAL SYSTEM

Starter Motor

- Replace the O-ring [A] with a new one.
- Install the following parts to the starter motor terminal [B].
 - O-ring
 - Collar [C]
 - Washer [D]
 - Starter Motor Terminal Locknut [E]
- Install the collar so that stepped side faces outward.
- Tighten:
 - **Torque - Starter Motor Terminal Locknut: 11 N·m (1.1 kgf·m, 97 in·lb)**

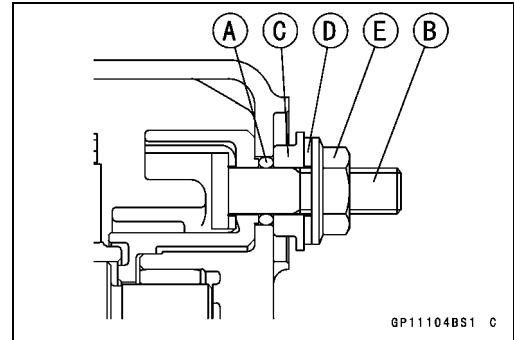

- Install the brush springs [A] and insert the brushes [B].

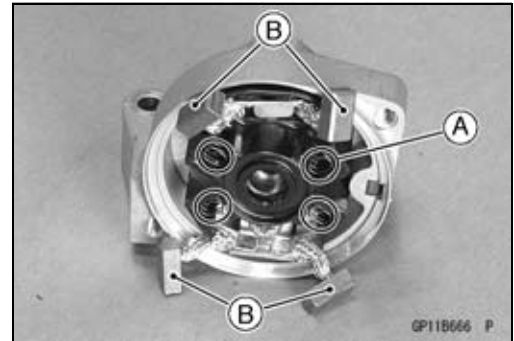

- Apply thin coat of grease to the oil seal [A].



- Replace the O-rings [A] with new ones.
- Insert the armature [D] so that commutator side [C] faces hollow side [B] of the yoke [E].

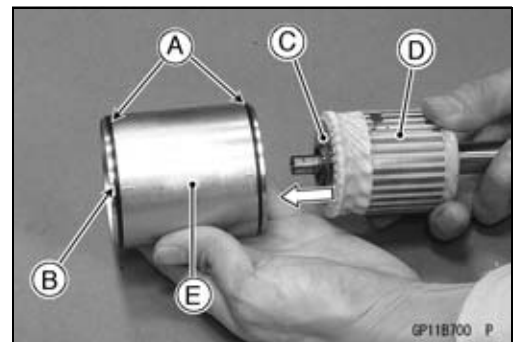

- Align the stopper [A] of the right-hand end cover to the groove [B] of the yoke.



Starter Motor

- Align the marks [A] to assembly the yoke and the end covers [B].

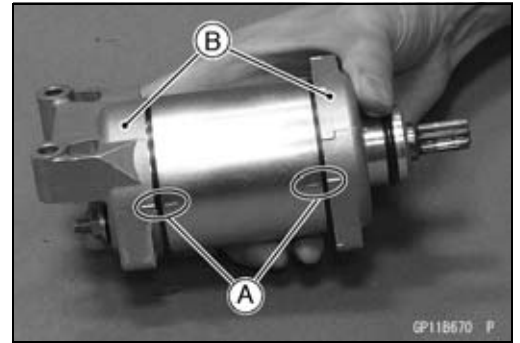

- Tighten:
Torque - Starter Motor Assy Bolts [A]: 5.0 N·m (0.51 kgf·m, 44 in·lb)



Brush Inspection

- Measure the length of each brush [A].
- ★ If any is worn down to the service limit, replace the brush assy.

Starter Motor Brush Length

Standard: 12 mm (0.47 in.)

Service Limit: 6.5 mm (0.26 in.)

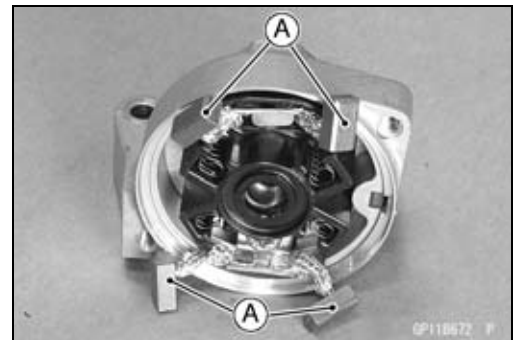

Commutator Cleaning and Inspection

- Clean the metallic debris off the between commutator segments [A].

NOTE

○ Do not use emery or sand paper on the commutator.

- Check the commutator for damage or abnormal wear.
- ★ Replace the starter motor with a new one if there is any damage or wear.
- Visually inspect the commutator segments for discoloration.
- ★ Replace the starter motor with a new one if discoloration is noticed.

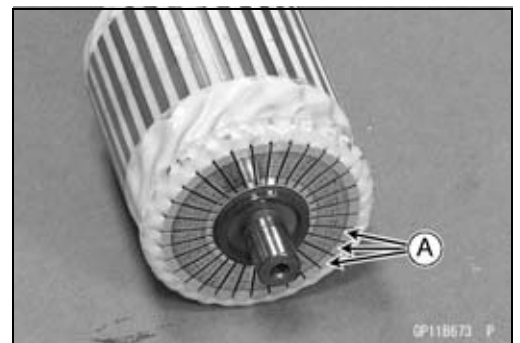

16-54 ELECTRICAL SYSTEM

Starter Motor

Armature Inspection

- Using the $\times 1 \Omega$ hand tester range, measure the resistance between any two commutator segments [A].

Special Tool - Hand Tester: 57001-1394

- ★ If there is a high resistance or no reading (∞) between any two segments, a winding is open and the starter motor must be replaced.
- Using the highest hand tester range, measure the resistance between the segments and the shaft [B].
- ★ If there is any reading at all, the armature has a short and the starter motor must be replaced.

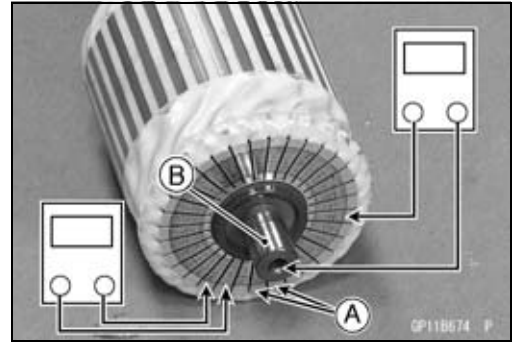

NOTE

○ Even if the foregoing checks show the armature to be good, it may be defective in some manner not readily detectable with the hand tester. If all other starter motor and starter motor circuit components check good, but the starter motor still does not turn over or only turns over weakly, replace the starter motor with a new one.

Brush Lead Inspection

- Using the $\times 1 \Omega$ hand tester range, measure the resistance as shown.

Terminal Bolt and Positive Brushes [A]

Right-hand End Cover and Negative Brushes [B]

Special Tool - Hand Tester: 57001-1394

- ★ If there is not close to zero ohms, the brush lead has an open. Replace the brush plate assy.

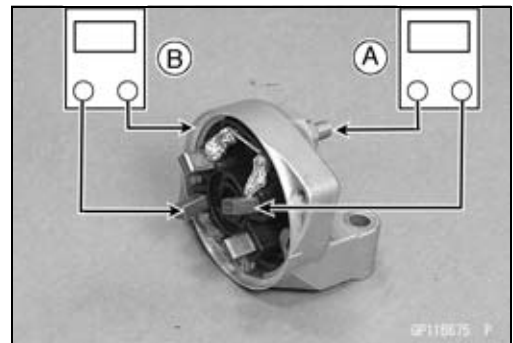

End Cover Inspection

- Using the highest hand tester range, measure the resistance as shown.

Terminal Bolt and End Cover [A]

Terminal Bolt and Negative Brushes [B]

Special Tool - Hand Tester: 57001-1394

- ★ If there is any reading, the brush assy and/or terminal bolt assy have a short. Replace the starter motor.

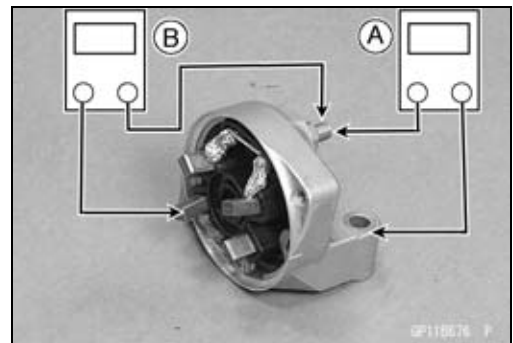

Starter Relay Removal

- Remove the battery negative (-) cable from the battery negative (-) [A] terminal (see Battery Removal).
- Disconnect:
 - Starter Motor Cable [B]
 - Battery Positive (+) Cable [C]
 - Connector [D]

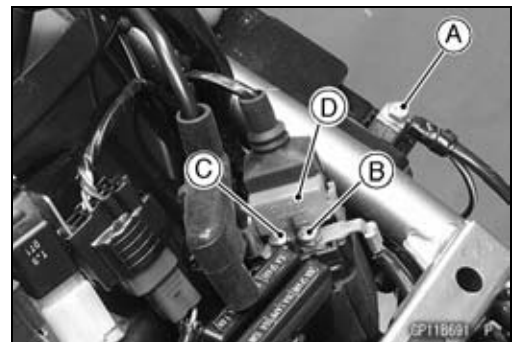

Starter Motor

- Push the rear fender front downward, remove the starter relay [A] from the rear fender front.



Starter Relay Inspection

- Remove:
Starter Relay (see Starter Relay Removal)
- Connect the hand tester [A] and 12 V battery [B] to the starter relay [C] as shown.

Special Tool - Hand Tester: 57001-1394

- ★ If the relay does not work as specified, the relay is defective. Replace the relay.

Testing Relay

Tester Range: × 1 Ω range

Criteria: When battery is connected → 0 Ω
When battery is disconnected → ∞ Ω

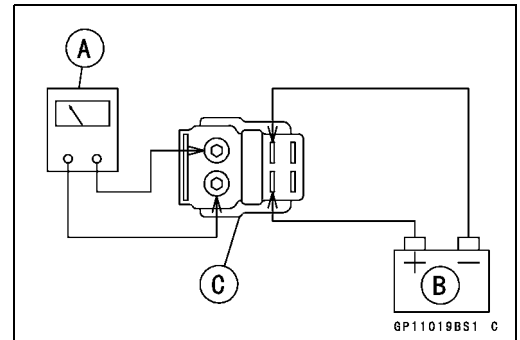

Starter Circuit Relay Inspection

- Remove:
Seat (see Seat Removal in the Frame chapter)
- Pull out starter circuit relay [A] from the frame bracket.
- Disconnect the connector to remove the relay.

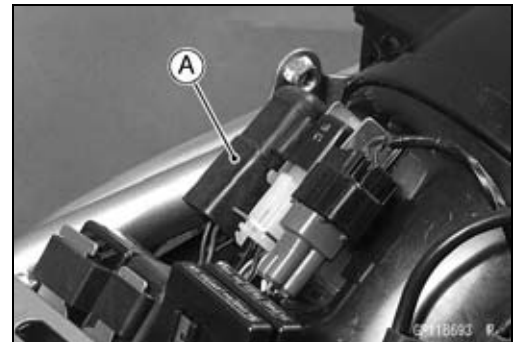

- Connect the hand tester [A] and a 12 V battery [B] to the starter circuit relay [C] as shown.

Special Tool - Hand Tester: 57001-1394

- ★ If the relay does not work as specified, the relay is defective. Replace the relay.

Testing Relay

Hand Tester Range: × 1 Ω

Criteria: When battery is connected → 0 Ω
When battery is disconnected → ∞ Ω

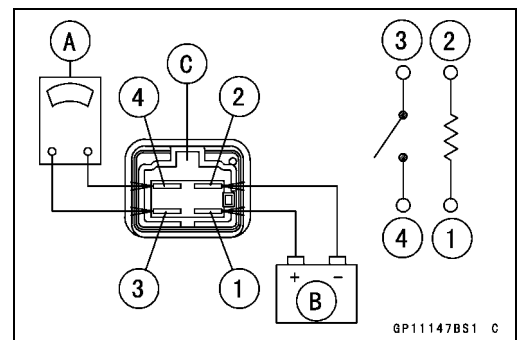

16-56 ELECTRICAL SYSTEM

Starter Motor

Electrical Starter Circuit

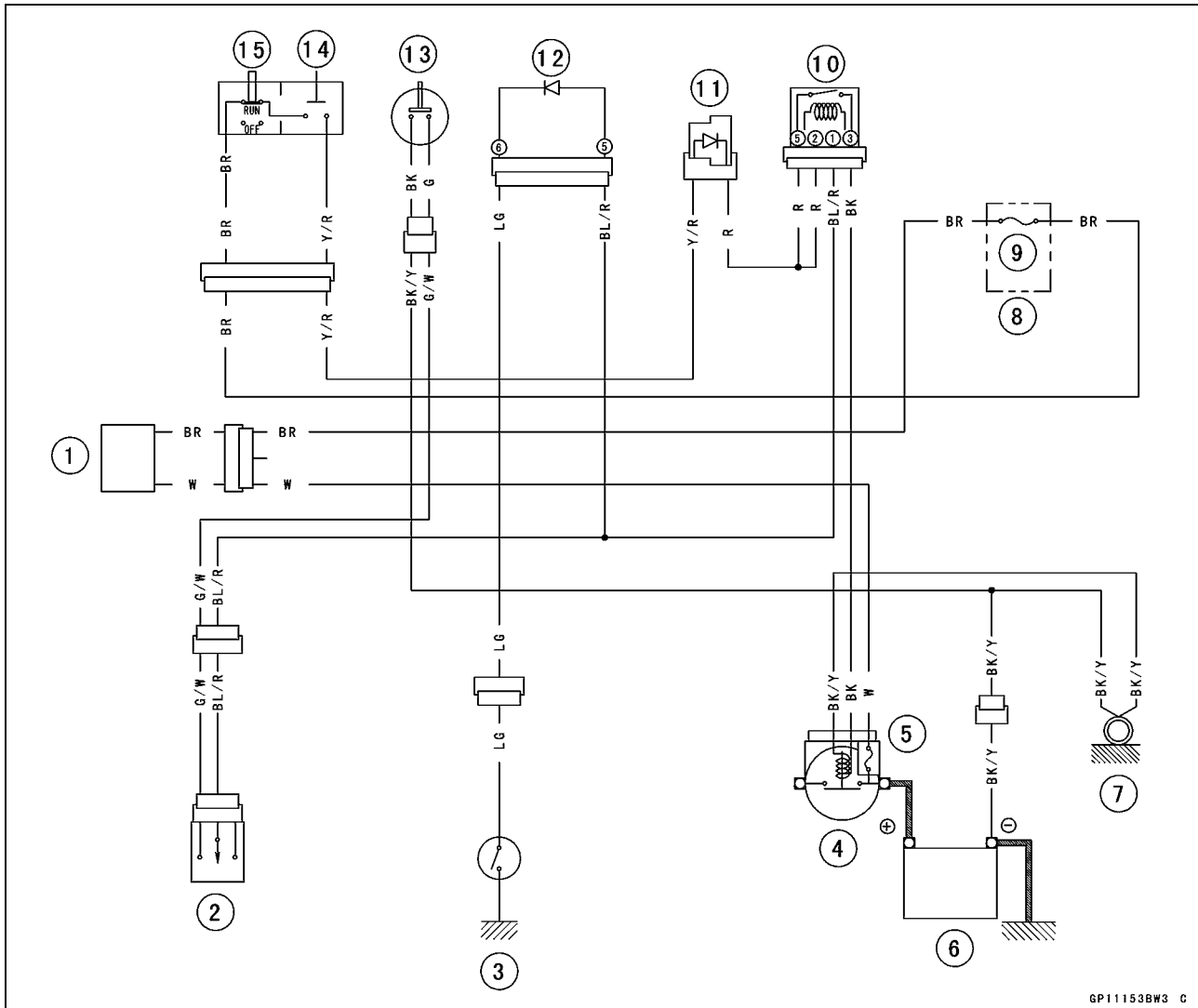

GP11153BW3 C

1. Ignition Switch
2. Starter Lockout Switch
3. Neutral Switch
4. Starter Relay
5. Main Fuse 20 A
6. Battery 12 V 6 Ah
7. Frame Ground
8. Fuse Box
9. Ignition Fuse 10 A
10. Starter Circuit Relay
11. Diode
12. Interlock Diode Unit
13. Sidestand Switch
14. Starter Button
15. Engine Stop Switch

Lighting System

Headlight Body Removal

- Remove:
 - Front Fender (see Front Fender Removal in the Frame chapter)
 - Bolts [A]
 - Headlight/Meter Cover [B]

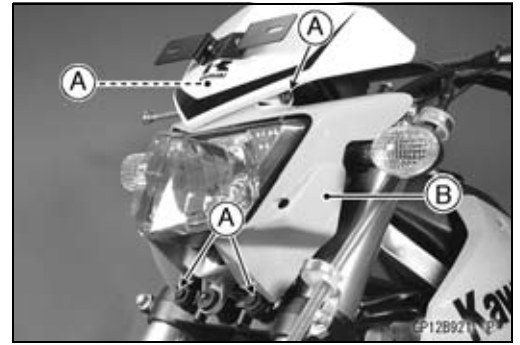

- Remove the headlight body mounting bolts [A].
- Pull the headlight body [B] forward.

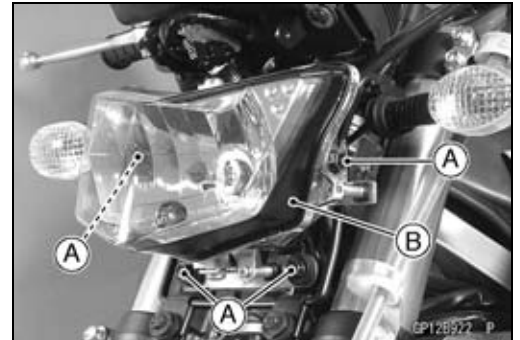

IN and EUR Models

- Disconnect the headlight connector [A] and city light connector [B] to remove the headlight body.

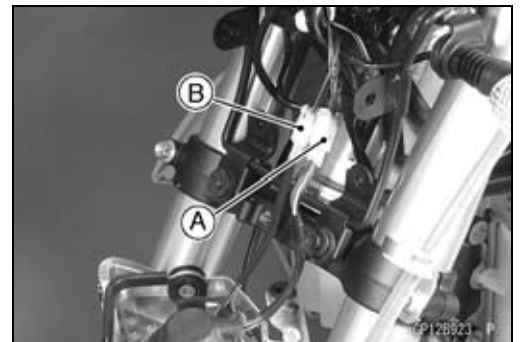

TH Model

- Disconnect the headlight connector [A] to remove the headlight body.

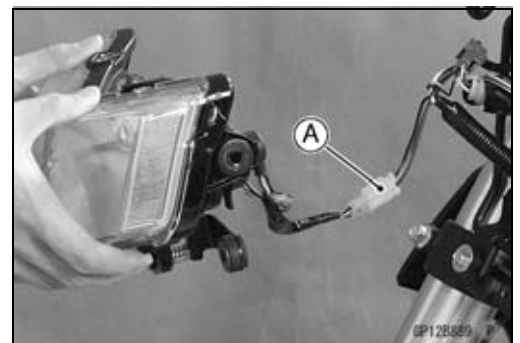

Headlight Aiming Inspection

- Refer to the Headlight Aiming Inspection in the Periodic Maintenance chapter.

16-58 ELECTRICAL SYSTEM

Lighting System

Headlight Bulb Replacement

SEA, BR, IN and EUR Models

- Remove the headlight body (see Headlight Body Removal).
- Remove the headlight bulb dust cover [A] from the headlight body.

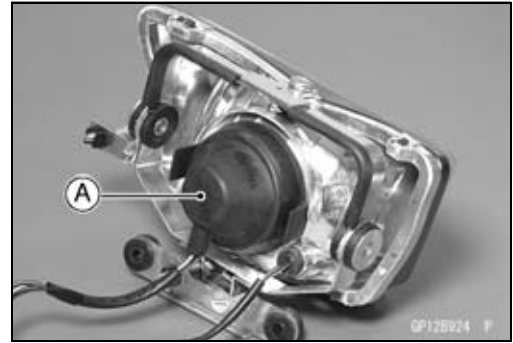

- Disconnect the connector [A].
- Push the hook [B] to unlock the headlight bulb.
- Remove the bulb [C].

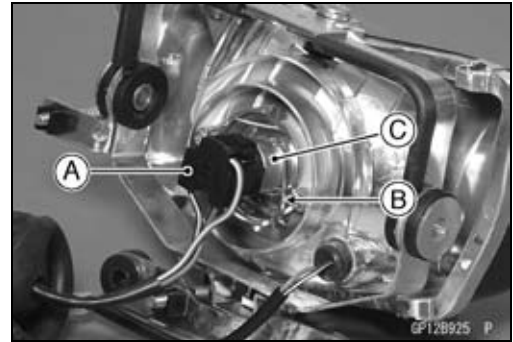

NOTICE

When handling the quartz-halogen bulb, never touch the glass portion with bare hands. Always use a clean cloth. Oil contamination from hands or dirty rags can reduce bulb life or cause the bulb to explode.

NOTE

○ Clean off any contamination that inadvertently gets on the bulb with alcohol or soap and water solution.

- Replace the headlight bulb.
- Fit the projections [A] of the bulb in the hollows of the headlight body.
- Install the hook [B].

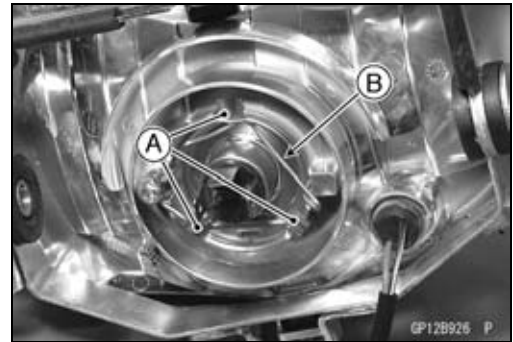

- Fit the dust cover [A] with the both knobs [B] sideward onto the headlight body [C] firmly as shown.
Good [D]
Bad [E]
- After installation, adjust the headlight aim (see Headlight Aiming Inspection in the Periodic Maintenance chapter).

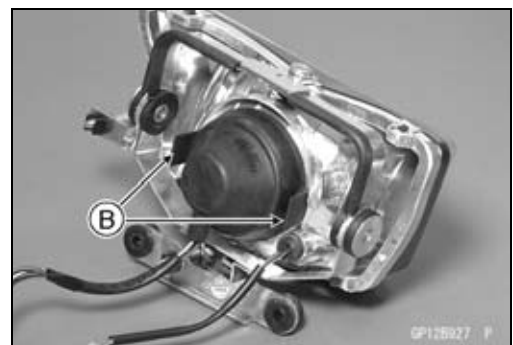
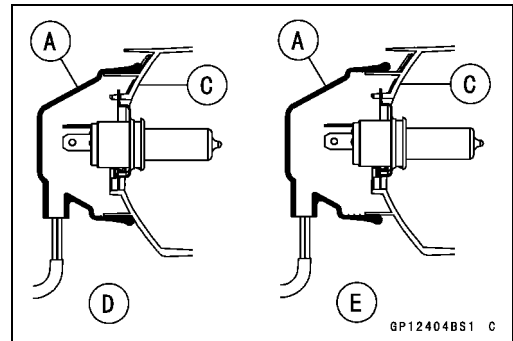

Lighting System

TH Model

- Remove the headlight body (see Headlight Body Removal).
- Remove the headlight bulb dust covers [A] from the headlight body.

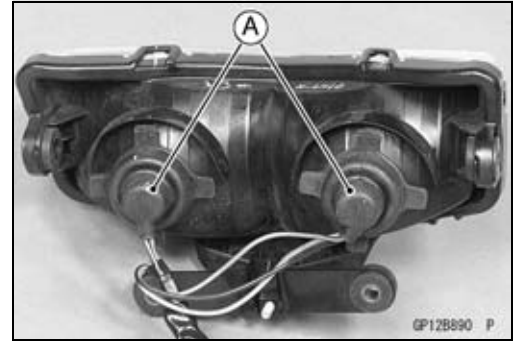

- Push and turn the lead plates [A] counterclockwise, and remove it.



- Remove the bulbs [A].

NOTICE

When handling the quartz-halogen bulb, never touch the glass portion with bare hands. Always use a clean cloth. Oil contamination from hands or dirty rags can reduce bulb life or cause the bulb to explode.



NOTE

○Clean off any contamination that inadvertently gets on the bulb with alcohol or soap and water solution.

- Replace the headlight bulbs with new ones.
- Fit the bulb tab [A] in to the headlight body groove [B].

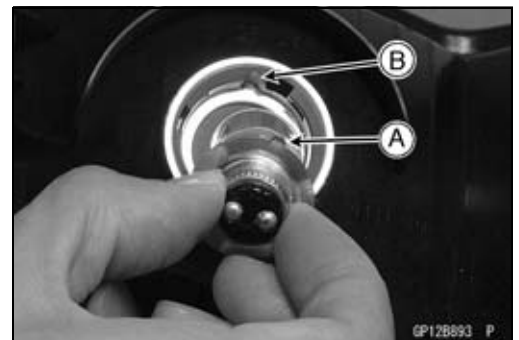

- Install the tabs [A] of the lead plate in to the rib slots [B] of the headlight body, and push and turn it clockwise.

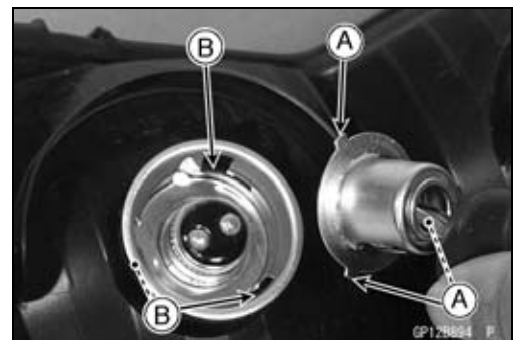

16-60 ELECTRICAL SYSTEM

Lighting System

- Fit the dust cover with the TOP mark [A] upward.

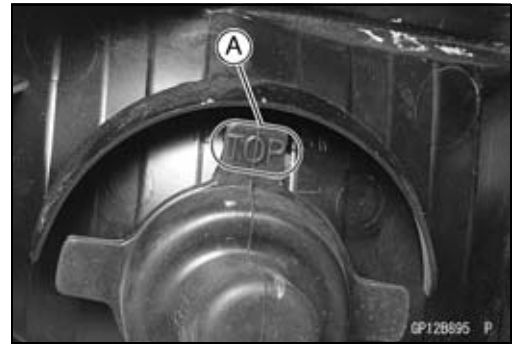

- Check the dust cover onto the headlight body as shown.
Correct [A]
Incorrect [B]

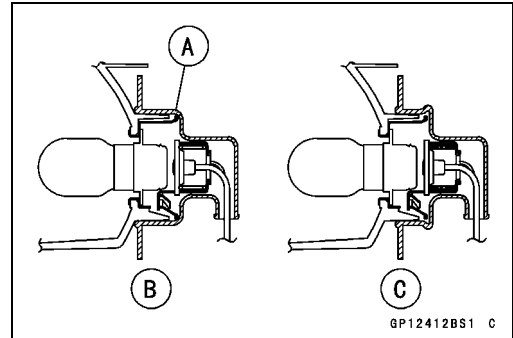

City Light Bulb Replacement (SEA, BR, IN and EUR Models)

- Remove the headlight body (see Headlight Body Removal).
- Pull out the socket [A] together with the bulb.

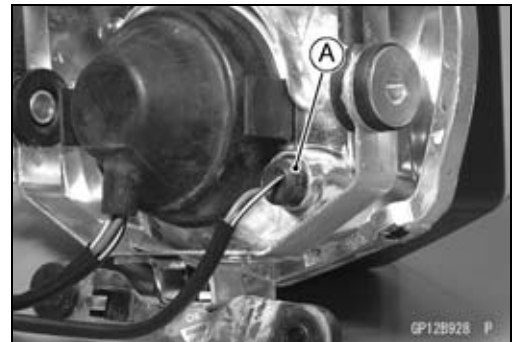

- Remove the wedge-base type bulb [A], pull the bulb straight out of the socket [B].

NOTICE

Do not turn the bulb. Pull the bulb out to prevent damage to the bulb. Do not use bulb rated for greater wattage than the specified value.

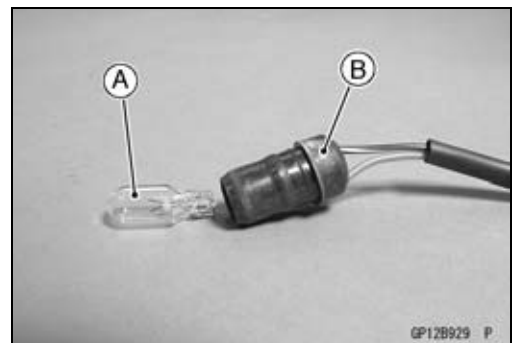

Tail/Brake Light Removal

- Remove:
Rear Fender Rear (see Rear Fender Rear Removal in the Frame chapter)
- Disconnect the tail/brake light lead connector [A].

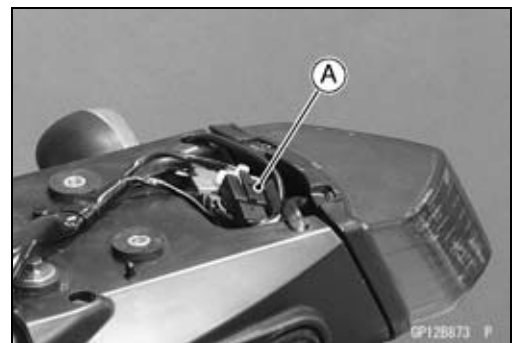

Lighting System

- Remove:
 - Nuts [A]
 - Tail/Brake Light Unit



Tail/Brake Light Bulb Replacement

- Remove:
 - Rear Fender Rear (see Rear Fender Rear Removal in the Frame chapter)
 - Screws [A]



- Clear the stoppers [A] from the tail/brake light body with a screwdriver [B] to remove the lens [C].

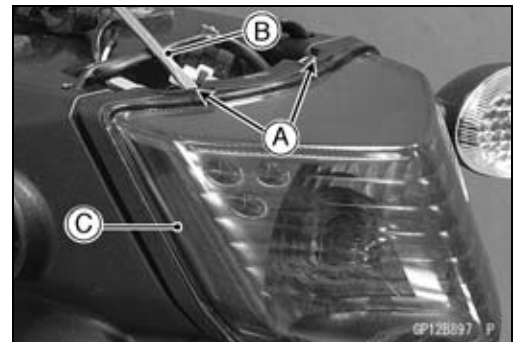

- Push and turn the bulb [A] counterclockwise [B] and remove it.
- Replace the bulb with a new one.



- Insert the new bulb [A] by aligning its upper and lower pins [B] with the upper and lower grooves [C] in the socket.
- Push and turn the bulb clockwise.

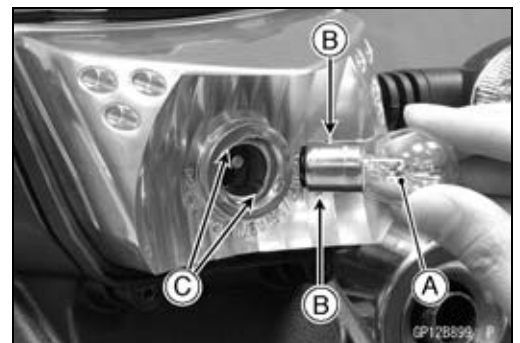

16-62 ELECTRICAL SYSTEM

Lighting System

- Install the taillight lens so that the stopper [A] fit the slits [B].
- Tighten:
Torque - Tail/Brake Light Lens Screws: 1.0 N·m (0.10 kgf·m, 8.8 in·lb)

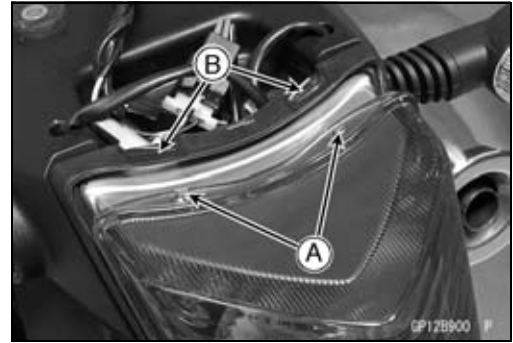

Headlight/Tail Light Circuit (IN Model)

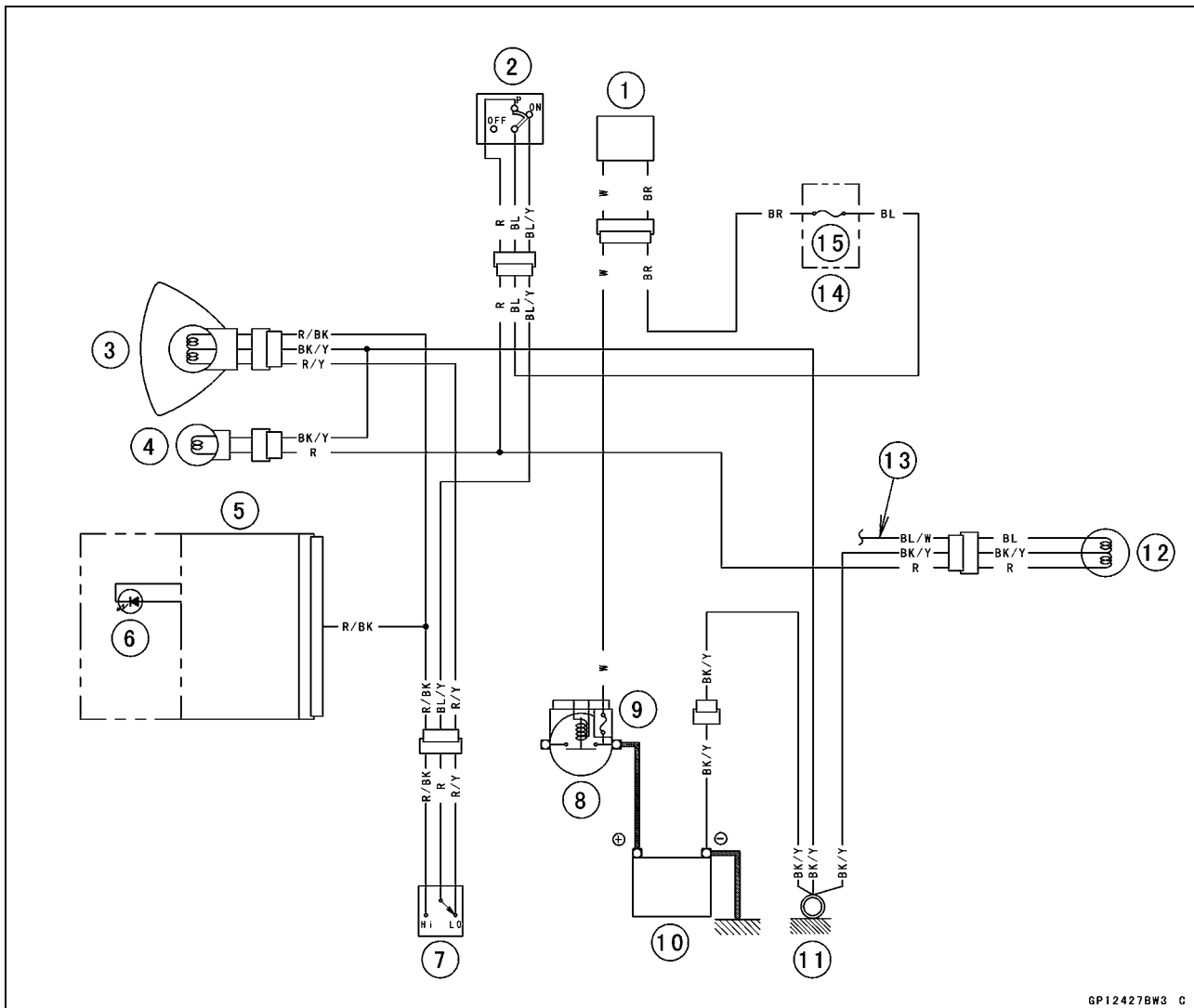

GP12427BW3 C

- | | |
|------------------------------------|--------------------------------------|
| 1. Ignition Switch | 9. Main Fuse 20 A |
| 2. Lighting Switch | 10. Battery 12 V 6 Ah |
| 3. Headlight 12 V 60/55 W | 11. Frame Ground |
| 4. City Light 12 V 5 W | 12. Tail/Brake Light 12 V 21/5 W |
| 5. Meter Unit | 13. To Front/Rear Brake Light Switch |
| 6. High Beam Indicator Light (LED) | 14. Fuse Box |
| 7. Dimmer Switch | 15. Lighting System Fuse 10 A |
| 8. Starter Relay | |

Lighting System

Headlight/Tail Light Circuit (BR, EUR, SEA Models)

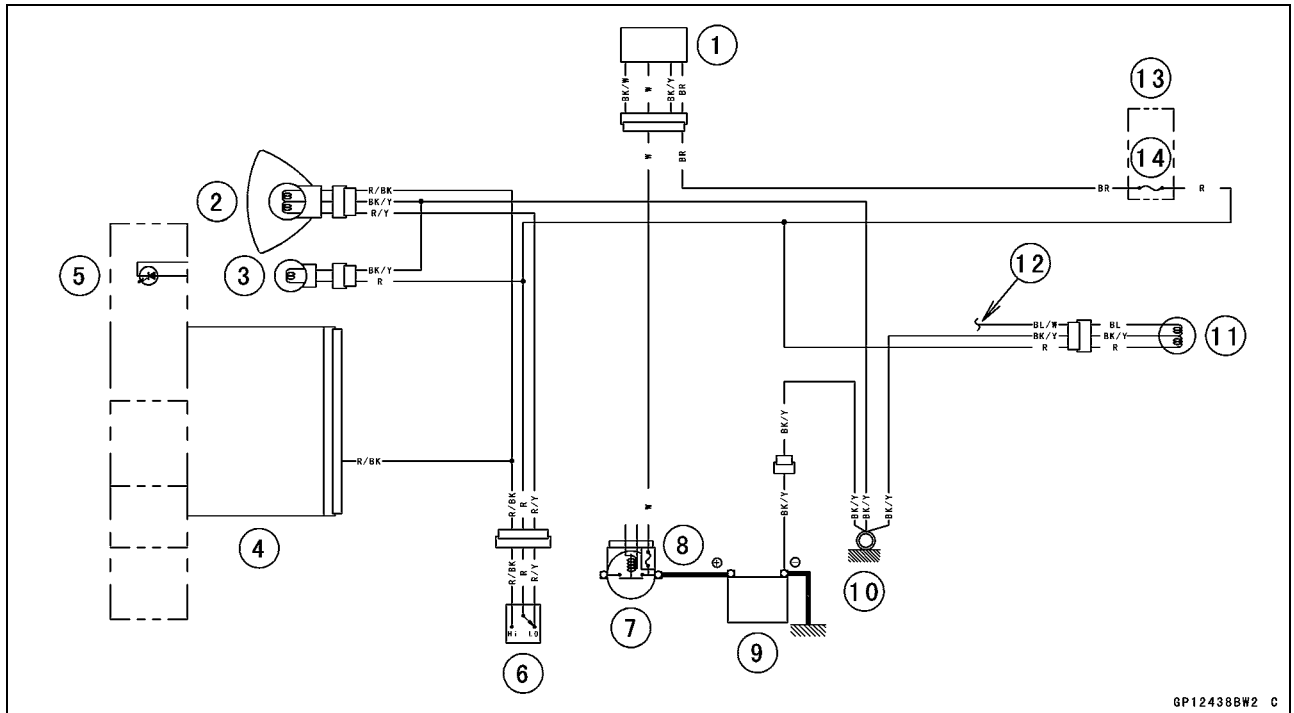

GP12438BW2 C

- | | |
|------------------------------------|--------------------------------------|
| 1. Ignition Switch | 8. Main Fuse 20 A |
| 2. Headlight 12 V 60/55 W | 9. Battery 12 V 6 Ah |
| 3. City Light 12 V 5 W | 10. Frame Ground |
| 4. Meter Unit | 11. Tail/Brake Light 12 V 21/5 W |
| 5. High Beam Indicator Light (LED) | 12. To Front/Rear Brake Light Switch |
| 6. Dimmer Switch | 13. Fuse Box |
| 7. Starter Relay | 14. Lighting System Fuse 10 A |

16-64 ELECTRICAL SYSTEM

Lighting System

Headlight/Tail Light Circuit (TH Model)

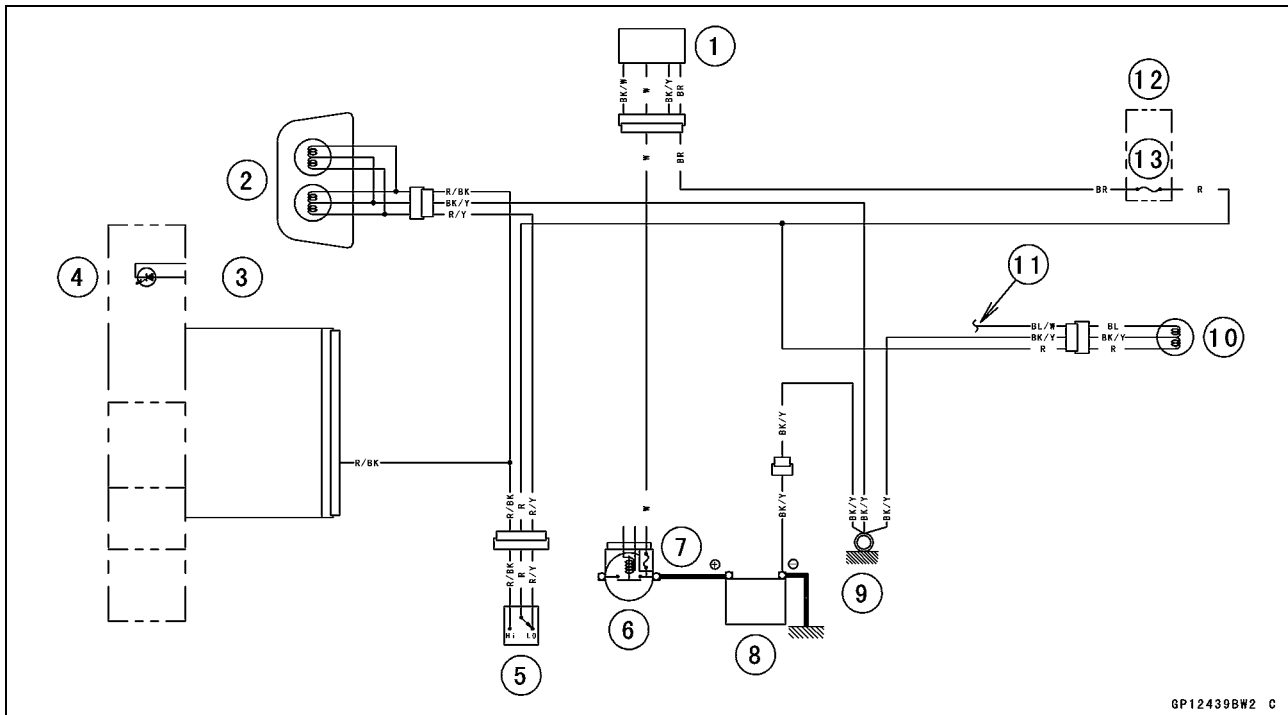

GP12439BW2 C

- | | |
|------------------------------------|--------------------------------------|
| 1. Ignition Switch | 7. Main Fuse 20 A |
| 2. Headlight 12 V 30/30 W × 2 | 8. Battery 12 V 6 Ah |
| 3. Meter Unit | 9. Frame Ground |
| 4. High Beam Indicator Light (LED) | 10. Tail/Brake Light 12 V 21/5 W |
| 5. Dimmer Switch | 11. To Front/Rear Brake Light Switch |
| 6. Starter Relay | 12. Fuse Box |
| | 13. Lighting System Fuse 10 A |

Turn Signal Light Bulb Replacement

- Remove the turn signal light lens screw [A] and take off the turn signal light lens [B].

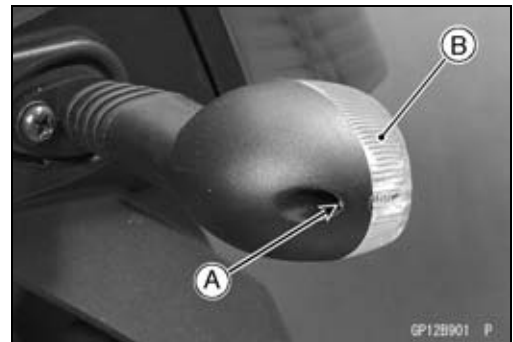

GP12B901 P

- Push and turn the bulb [A] counterclockwise [B], and remove it.
- Replace the bulb with a new one.

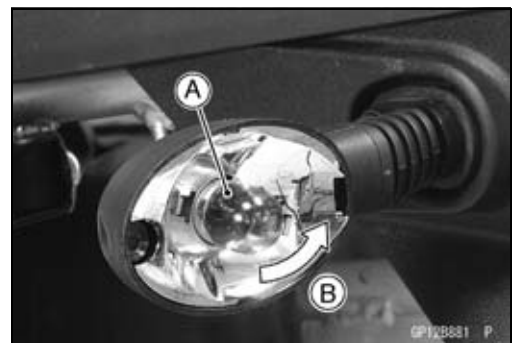

GP12B881 P

Lighting System

- Insert the new bulb [A] by aligning its upper and lower pins [B] with the upper and lower grooves [C] in the socket, and turn the bulb clockwise.
- Install the turn signal light lens.
- Tighten the turn signal light lens screw. Be careful not to overtighten it.

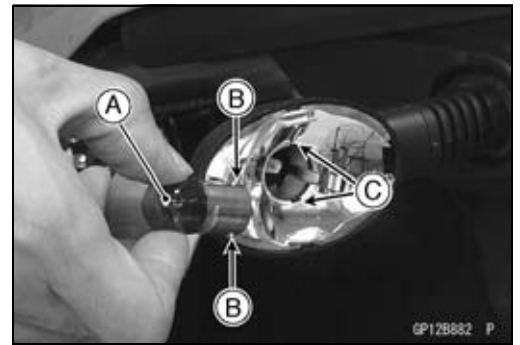

Turn Signal Relay Inspection

NOTICE

Never drop the turn signal relay, especially on a hard surface. Such a shock can damage it.

- Remove:
 - Seat (see Seat Removal in the Frame chapter)
 - Turn Signal Relay [A]
- Connect 12 V battery and turn signal lights as indicated in the figure, and count how many times the lights flash for one minute.
 - Turn Signal Relay Connector [A]
 - Turn Signal Lights [B]
 - 12 V Battery [C]

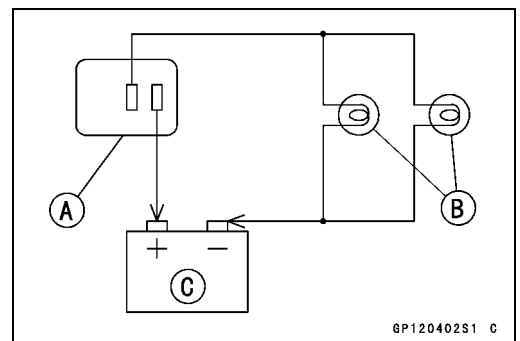
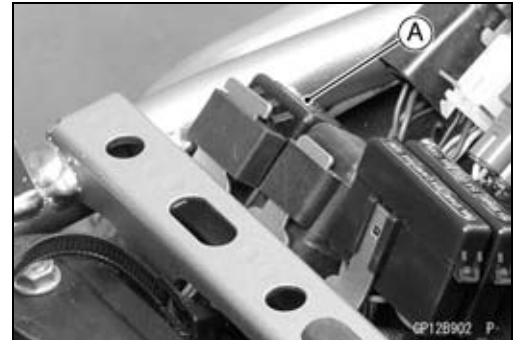

Testing Turn Signal Relay

Load		
The Number of Turn Signal Light	Wattage (W)	Flashing times (c/m)*
1**	10	140 ~ 250
2	20	75 ~ 95

(*): Cycle(s) per minute

(**): Corrected to "one light burned out".

- ★ If the lights do not flash as specified, replace the turn signal relay.

16-66 ELECTRICAL SYSTEM

Lighting System

Turn Signal Light Circuit

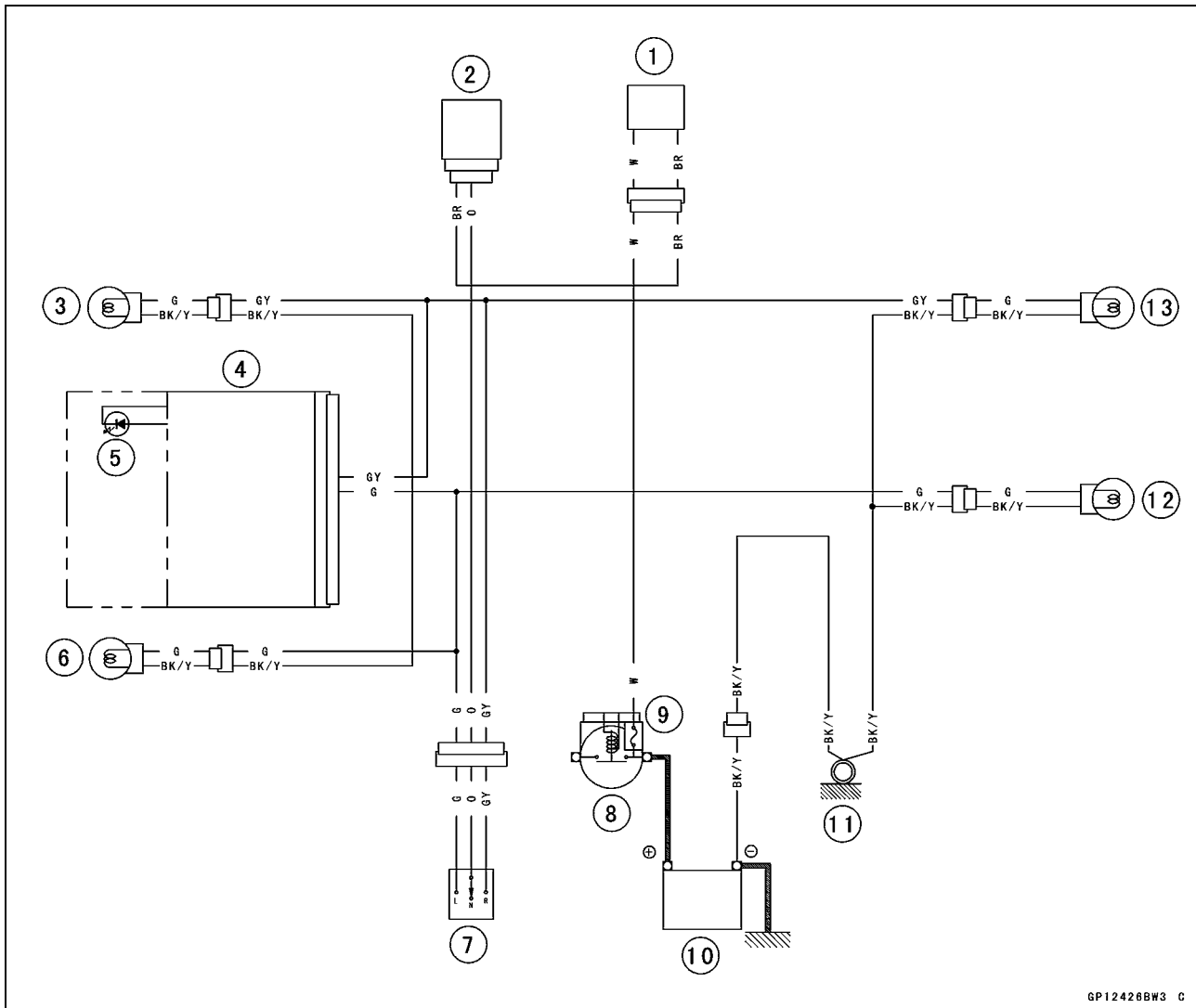

GP12428BW3 C

1. Ignition Switch
2. Turn Signal Relay
3. Front Right Turn Signal Light 12 V 10 W
4. Meter Unit
5. Turn Signal Indicator Light (LED)
6. Front Left Turn Signal Light 12 V 10 W
7. Turn Signal Switch
8. Starter Relay
9. Main Fuse 20 A
10. Battery 12 V 6 Ah
11. Frame Ground
12. Rear Left Turn Signal Light 12 V 10 W
13. Rear Right Turn Signal Light 12 V 10 W

Air Switching Valve

Air Switching Valve Operation Test

- Refer to the Air Suction System Damage Inspection in the Periodic Maintenance chapter.

Air Switching Valve Unit Test

- Remove the air switching valve (see Air Switching Valve Removal in the Engine Top End chapter).
- Set the hand tester [A] to the $\times \Omega$ range and connect it to the air switching valve terminals as shown.

Special Tool - Hand Tester: 57001-1394

Air Switching Valve Resistance

Standard: 24 ~ 28 Ω at 20°C (68°F)

- ★ If the resistance reading is except the specified value, replace it with a new one.
- Connect the 12 V battery [A] to the air switching valve terminals as shown.

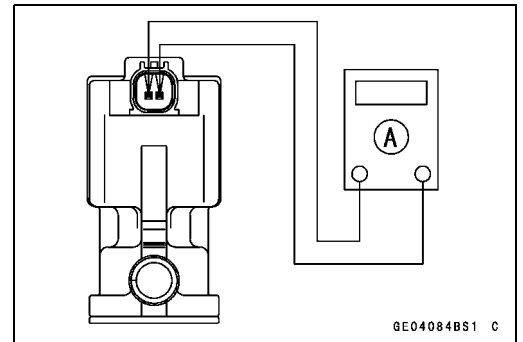

GE04084BS1 C

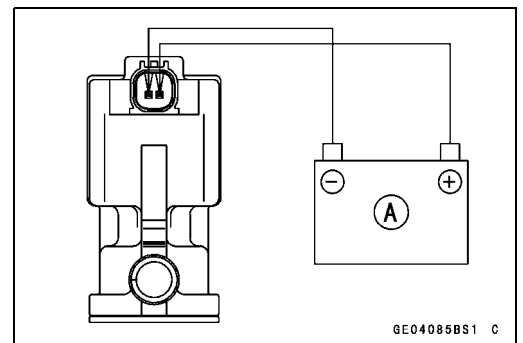

GE04085BS1 C

- Blow the air to the inlet air duct [A], and make sure does not flow the blown air from the outlet air duct [B].

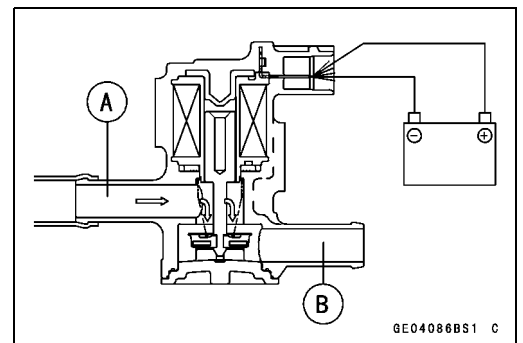

GE04086BS1 C

- Disconnect the 12 V battery.
- Blow the air to the inlet air duct [A] again, and make sure flow the blown air from the outlet air duct [B].
- ★ If the air switching valve does not operate as described, replace it with a new one.

NOTE

○ To check air flow through the air switching valve, just blow through the air cleaner hose [C].

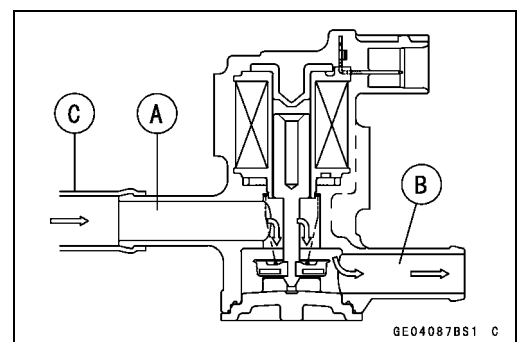

GE04087BS1 C

16-68 ELECTRICAL SYSTEM

Air Switching Valve

Air Switching Valve Circuit

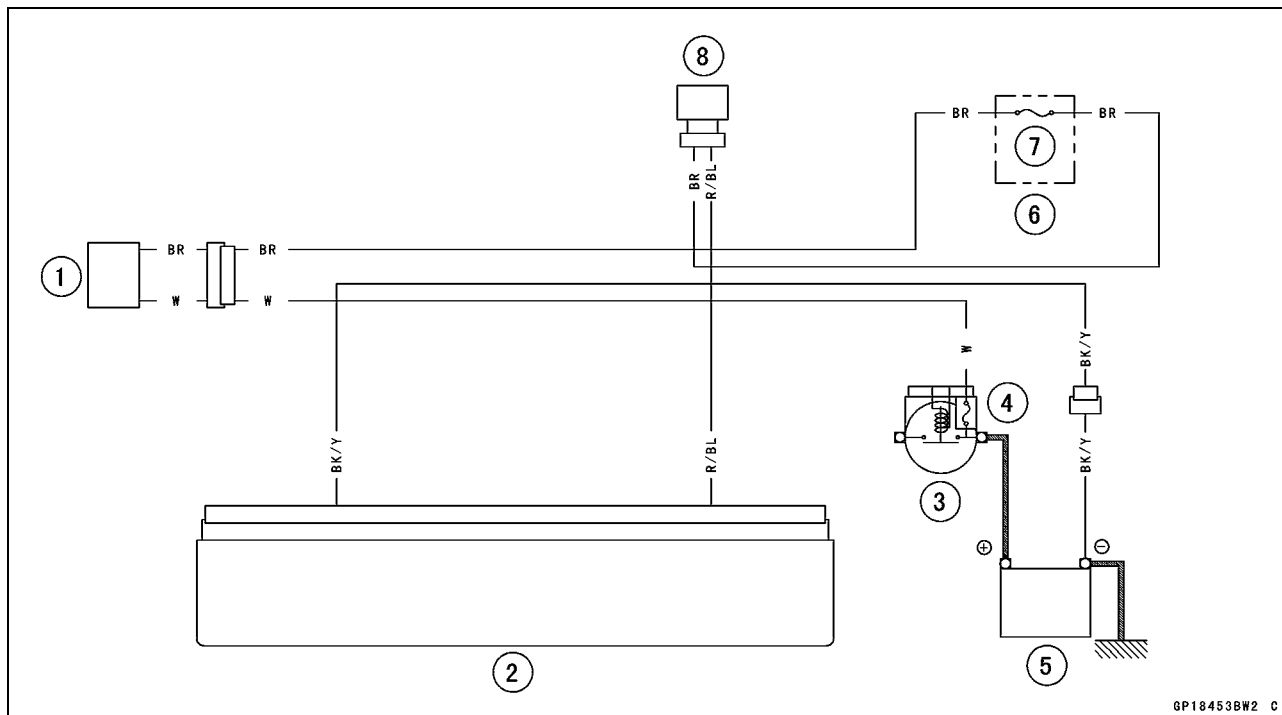

GP18453BW2 C

1. Ignition Switch
2. ECU
3. Starter Relay
4. Main Fuse 20 A
5. Battery 12 V 6 Ah
6. Fuse Box
7. Ignition Fuse 10 A
8. Air Switching Valve

Radiator Fan System

Radiator Fan Relay Inspection

- Remove:
 - Seat (see Seat Removal in the Frame chapter)
 - Fan Relay [A]

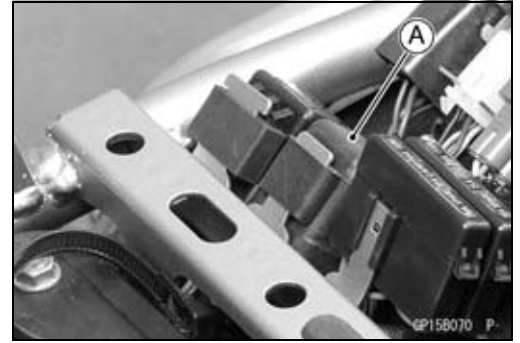

- Connect the hand tester [A] and a 12 V battery [B] to the starter circuit relay [C] as shown.

Special Tool - Hand Tester: 57001-1394

- ★ If the relay does not work as specified, the relay is defective. Replace the relay.

Testing Relay

Hand Tester Range: $\times 1 \Omega$

Criteria: **When battery is connected $\rightarrow 0 \Omega$**
 When battery is disconnected $\rightarrow \infty \Omega$

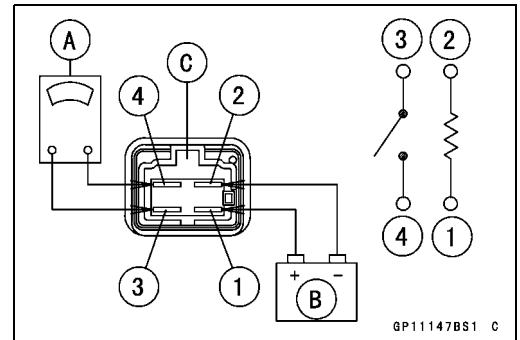

Fan Motor Inspection

- Remove the fuel tank (see Fuel Tank Removal in the Fuel System (DFI) chapter).
- Disconnect the radiator fan lead connector [A].
- Using an auxiliary leads, supply battery [B] power to the fan motor.
- ★ If the fan does not rotate, the fan motor is defective and must be replaced.

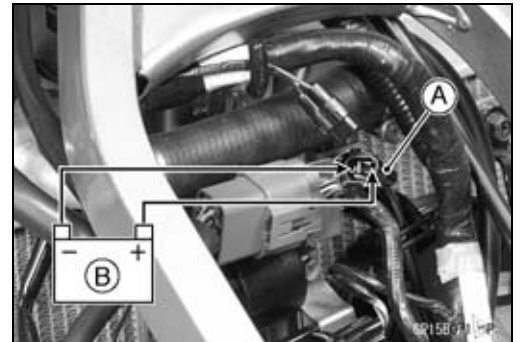

16-70 ELECTRICAL SYSTEM

Radiator Fan System

Radiator Fan Circuit

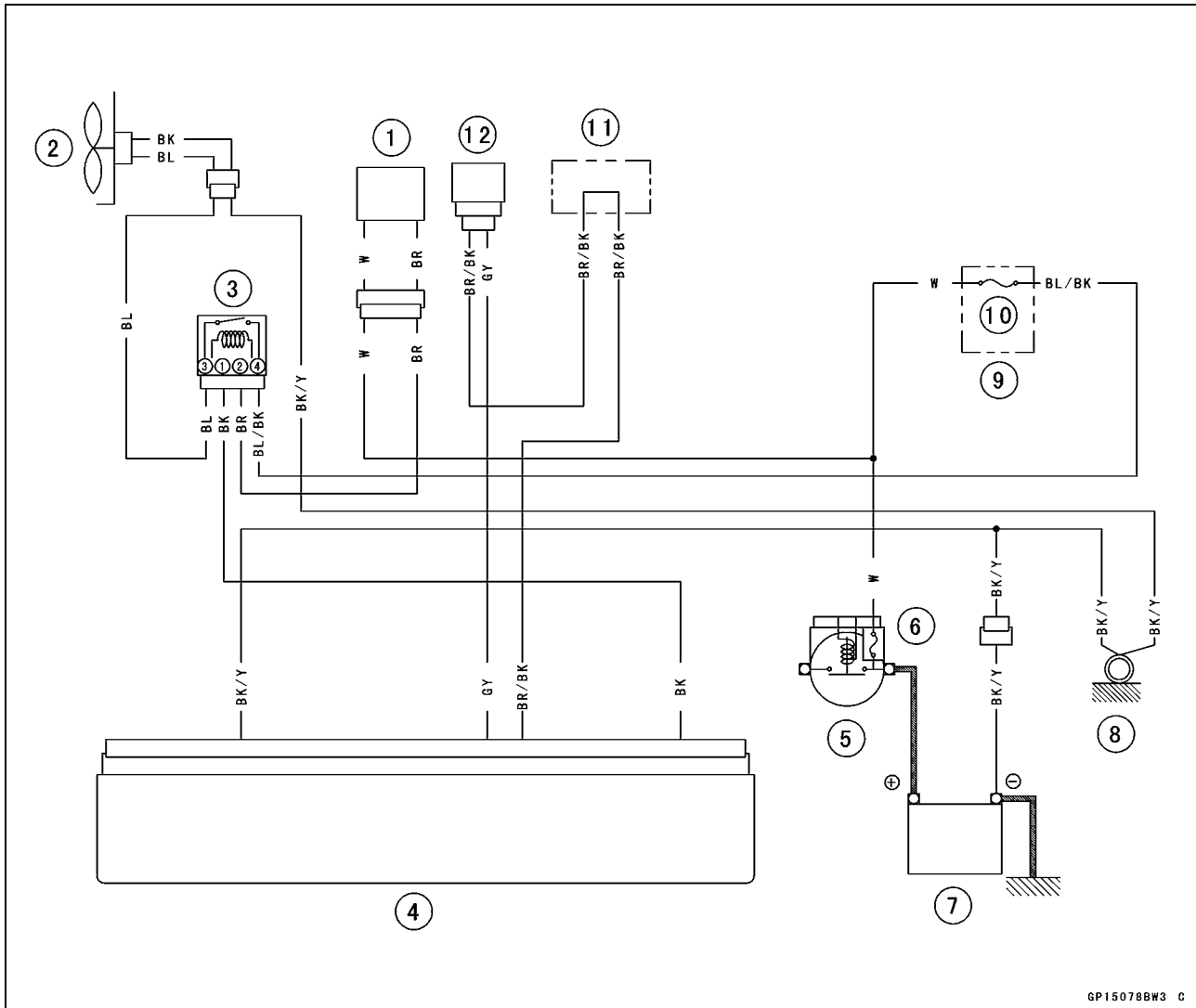

GP15078BW3 C

1. Ignition Switch
2. Radiator Fan
3. Fan Relay
4. ECU
5. Starter Relay
6. Main Fuse 20 A

7. Battery 12 V 6 Ah
8. Frame Ground
9. Fuse Box
10. Radiator Fan Fuse 10 A
11. Water-proof Joint
12. Water Temperature Sensor

Meter, Gauge

Meter Unit Removal

- Remove:
 - Headlight/Meter Cover (see Headlight Body Removal)
 - Screws [A] and Washer
 - Meter Unit [B]
- Disconnect the meter connector [C].

NOTICE

Do not drop the meter unit. Place the meter unit so that face is up. If a meter unit is left upside down or sideways for a long time or dropped, it will malfunction.

Meter Unit Installation

- Connect the meter connector [A].
- Install the meter unit [B], and tighten the mounting screws [C] securely.

Meter Unit Disassembly

- Remove:
 - Meter Unit (see Meter Unit Removal)
 - Screws [A]
 - Lower Meter Cover [B]
- Separate the meter assembly [A] and upper meter cover [B].

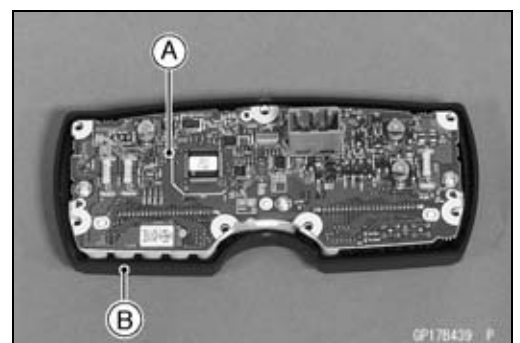
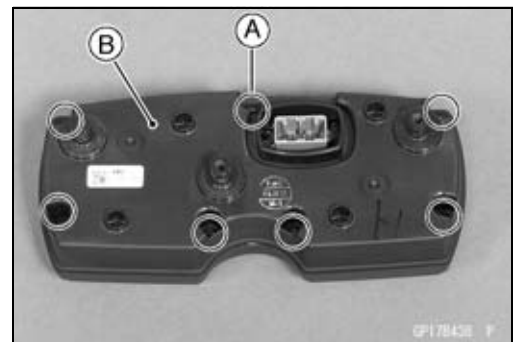
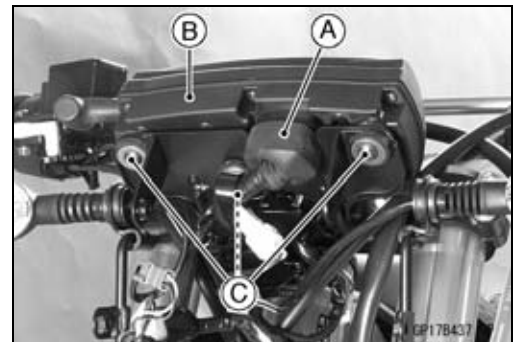
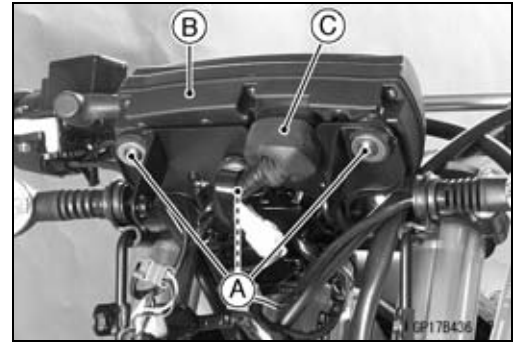

16-72 ELECTRICAL SYSTEM

Meter, Gauge

Meter Unit Inspection

- Remove the meter unit [A] (see Meter Unit Removal).
 - [1] Tachometer Signal
 - [2] Speed Sensor Signal
 - [3] Unused
 - [4] Unused
 - [5] Speed Sensor Power Supply
 - [6] Ground (-)
 - [7] Ignition
 - [8] Battery (+)
 - [9] Neutral Indicator Light (LED) (-)
 - [10] High Beam Indicator Light (LED) (+)
 - [11] Right Turn Signal Indicator Light (LED) (+)
 - [12] Left Turn Signal Indicator Light (LED) (+)
 - [13] Water Temperature Warning Indicator Light (LED) (-)
 - [14] FI Indicator Light (LED) (-)
 - [15] Unused
 - [16] Fuel Level Warning Indicator Light (LED) (-)

NOTICE

Do not drop the meter unit. Place the meter unit so that it faces upward. If the meter assembly is left upside down or sideways for a long time or dropped, it will malfunction. Do not short each terminals.

Liquid Crystal Display (LCD) Segments Check

- Using the insulated auxiliary leads, connect the 12 V battery to the meter unit connector as follows.
 - Connect the battery positive terminal to the terminal [8].
 - Connect the battery negative terminal to the terminal [6].

- Connect the terminal [7] to the terminal [8].

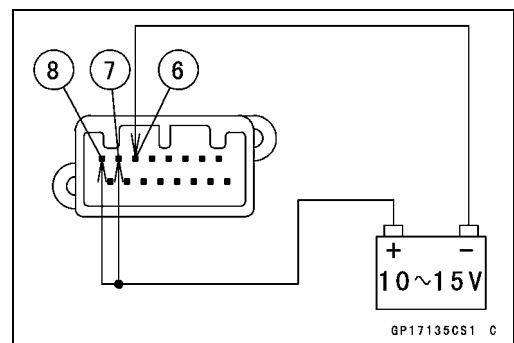
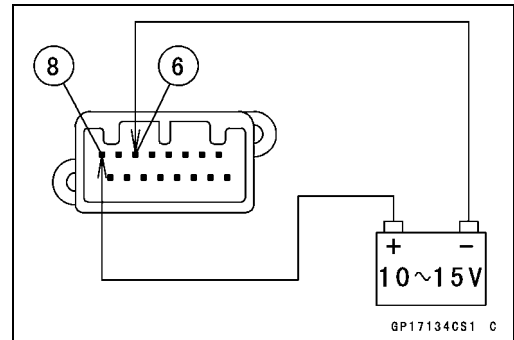
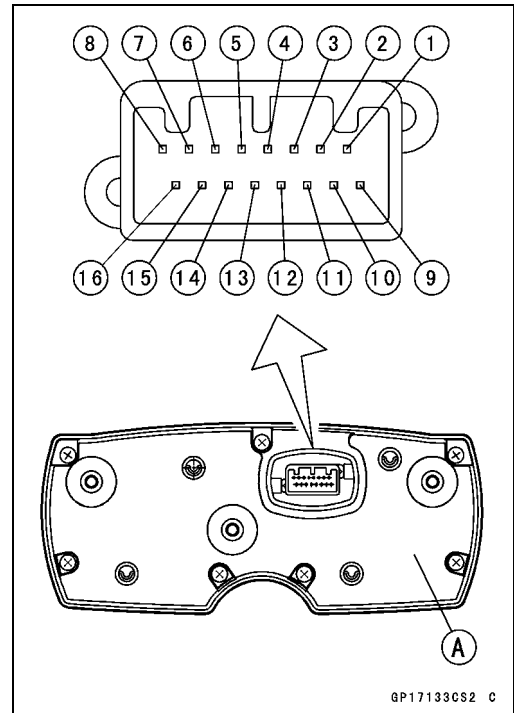

Meter, Gauge

- When the terminals are connected, all the LCD segments [A] and all indicator lights (LED) [B] appear for three seconds.
- When the terminals are connected, tachometer momentarily goes from the minimum to the maximum, then goes back from the maximum to the minimum reading.
- ★ If the LCD segments will not appear, replace the meter assembly.
- Disconnect the terminal [7].
- All the LCD segments disappear.
- ★ If the segments do not disappear, replace the meter assembly.
- Connect the terminal [7] to the terminal [8] again.
- About 5 seconds after, the fuel level warning indicator light (LED) blinks [A] and the FUEL segments [B] appears in the display.
- The FUEL segments is flashing.
- ★ If the fuel level warning indicator light (LED) does not blink and/or the FUEL segments does not appear, replace the meter unit.

NOTE

- This meter unit has a failure detection function (for open or short) of the fuel reserve switch. When the fuel reserve switch is open or short, the meter unit alerts the rider by the fuel level warning indicator light (LED) blinks and the FUEL segments appears in the display.
- If the failure detection function operates with the meter unit installed on the motorcycle, inspect the fuel reserve switch (see Fuel Reserve Switch Inspection) and wiring.

Speed Sensor Power Inspection

- Using the insulated auxiliary leads, connect the 12 V battery to the meter unit connector as follows.
- Connect the battery positive terminal to the terminal [8].
- Connect the battery negative terminal to the terminal [6].
- Set the hand tester [A] to the 25 V DC range and connect terminal [5] and [6].

Special Tool - Hand Tester: 57001-1394

- ★ If the voltage is not battery voltage, replace the meter assembly.

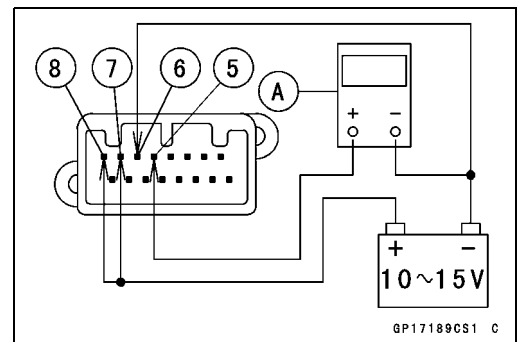
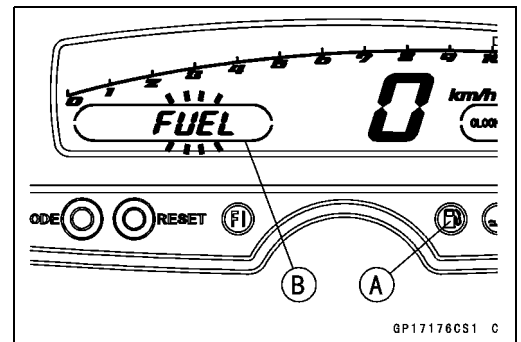
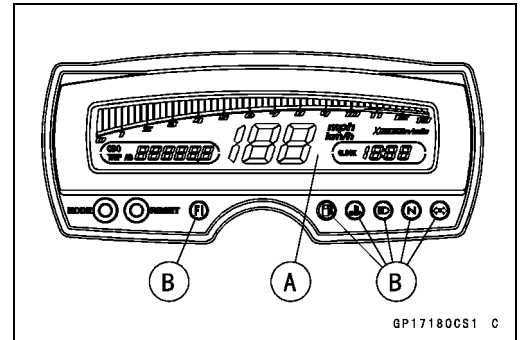

16-74 ELECTRICAL SYSTEM

Meter, Gauge

MODE AND RESET BUTTON Operation Check

- Connect the 12 V battery and terminals in the same manner as specified in the "Liquid Crystal Display (LCD) Segments Check".
- Check that the display [A] change to the ODO, TRIP A and TRIP B displays each time the MODE button [B] is pressed.
- ★ If the display function does not work, replace the meter assembly.
- [C] RESET button
- When fuel level warning indicator light (LED) blinks, the display changes in order of FUEL, ODO, TRIP A and TRIP B.

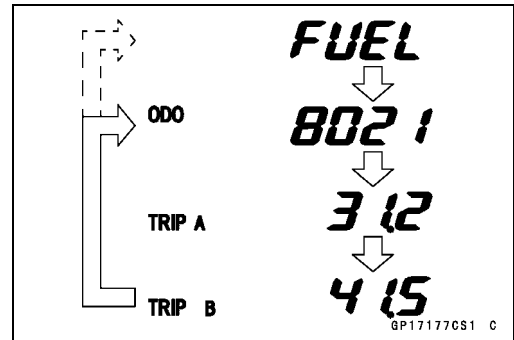
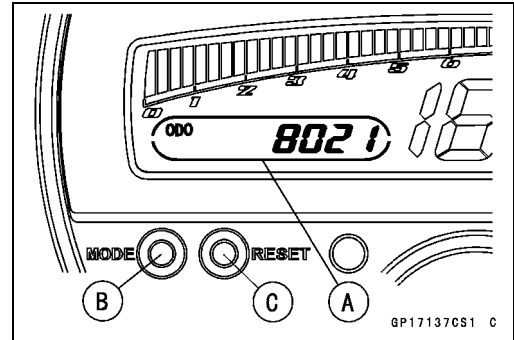

- Check that when the RESET button in CLOCK mode is pushed for more than two seconds, the meter display turns to the clock set mode.
- Both the hour and minute display start flashing.

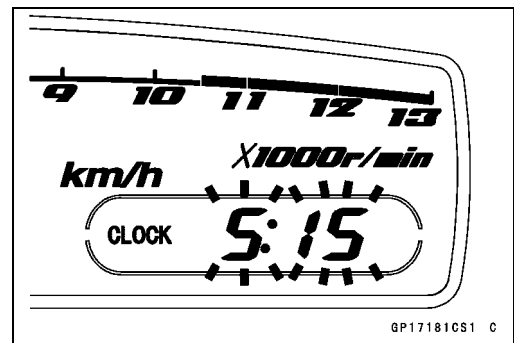

- In the HOUR/MINUTE setting mode, press the reset button again to effect the HOUR setting mode.
- The hour display flashes on the display.
- Press the MODE button to set the hour.

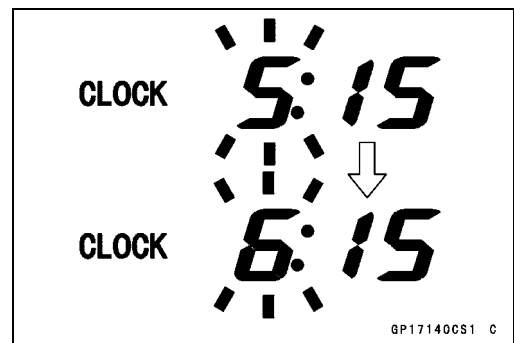

- In the HOUR setting mode, press the RESET button to effect the MINUTE setting mode.
- The minute display flashes on the display.
- Press the MODE button to set the minute.

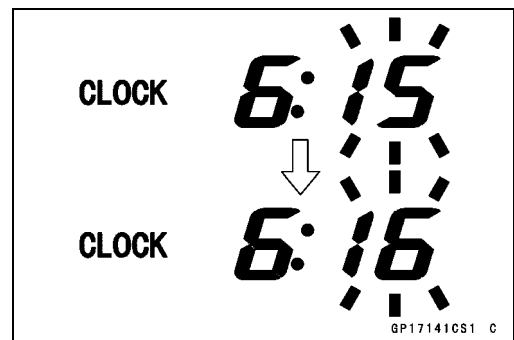

Meter, Gauge

- In the MINUTE setting mode, press the RESET button to return to the HOUR/MINUTE setting mode.
- Press the MODE button to complete the time setting process.
- The clock starts counting the seconds as soon as the MODE button is pressed.

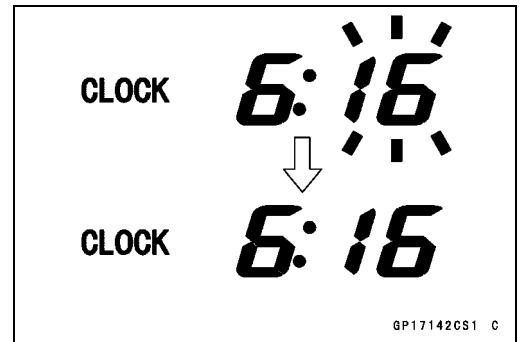

- Indicate the ODO mode.
- Check that the display [A] change to the mile and km display each time by pushing the RESET button while MODE button pushed in.

NOTE

○ Mile/Km Display can alternate between English and metric modes (mile and km) in the digital meter. Make sure that km or mile according to local regulations is correctly displayed before riding.

- ★ If the display function does not work and adjust, replace the meter assembly.

Speedometer Check

- Connect the 12 V battery and terminals in the same manner as specified in the "Liquid Crystal Display (LCD) Segments Check".
- The speed equivalent to the input frequency is indicated in the oscillator [A], if the square wave (illustrated as shown) would be input into the terminal [2].

KLX250S Model

- Indicates approximately 60 km/h in case the input frequency would be approximately 60 Hz.
- Indicates approximately 60 mph in case the input frequency would be approximately 96 Hz.

KLX250V Model

- Indicates approximately 60km/h in case the input frequency would be approximately 71.3Hz.
- Indicates approximately 60mph in case the input frequency would be approximately 114.1Hz.
- If the oscillator is not available, the speedometer can be checked as follows.
 - Install the meter unit.
 - Raise the rear wheel off the ground, using the jack.
 - Turn on the ignition switch.
 - Rotate the rear wheel by hand.
 - Check that the speedometer shows the speed.
- ★ If the speedometer does not work, check the speed sensor and wiring (see Speed Sensor section in the Fuel System (DFI) chapter).
- ★ If the speed sensor and wiring are normal, replace the meter assembly.

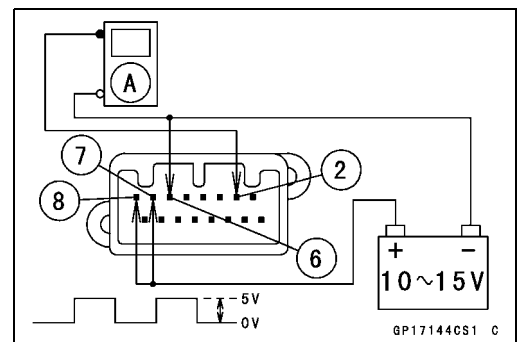
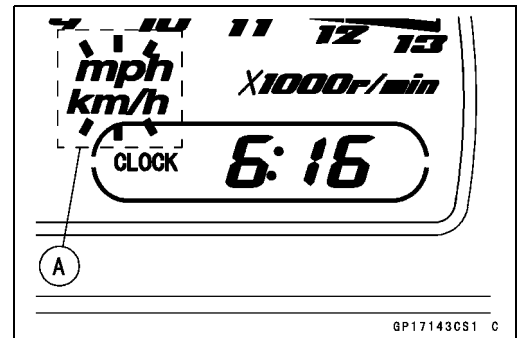

16-76 ELECTRICAL SYSTEM

Meter, Gauge

Odometer Check

- Check the odometer with the speedometer check in the same way.
- ★ If value indicated in the odometer is not added, replace the meter assembly.

NOTE

- The data is maintained even if the battery is disconnected.
- When the figures come to 999999, they are stopped and locked.

Trip Meter Check

- Check the trip meter with the speedometer check in the same way.
- ★ If value indicated in the trip meter is not added, replace the meter assembly.
- Check that when the RESET button is pushed for more than two seconds, the figure display turns to 0.0.
- ★ If the figure display does not indicate 0.0, replace the meter assembly.

Tachometer Check

- Connect the 12 V battery and terminals in the same manner as specified in the "Liquid Crystal Display (LCD) Segments Check".
- When the terminals are connected, the tachometer momentarily goes from the minimum to the maximum, then goes back from the maximum to the minimum reading.
- ★ If the tachometer segments function does not work, replace the meter assembly.
- The revolutions per minute (rpm) equivalent to the input frequency is indicated in the oscillator [A] if the square wave (illustrated as shown) would be input into the terminal [1].
- Indicates approximately 4 000 rpm in case the input frequency would be approximately 33.3 Hz.
- If the oscillator is not available, the tachometer can be checked as follows.
- Connect the 12 V battery and terminals in the same manner as specified in the "Liquid Crystal Display (LCD) Segments Check".
- When the terminals are connected, the tachometer momentarily goes from minimum to the maximum, then goes back from the maximum to the minimum reading.
- ★ If the tachometer segments function does not work, replace the meter assembly.
- Using the insulated auxiliary lead, quickly open and connect the terminal [7] to the terminal [1] repeatedly.
- Then the tachometer segments [A] should flick [B].
- ★ If the hand does not flick, replace the meter assembly.

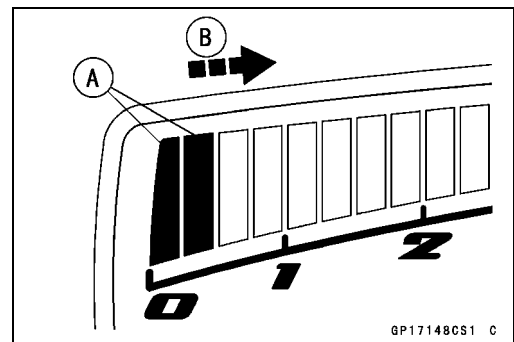
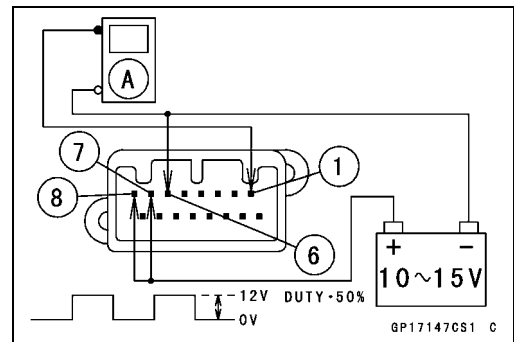
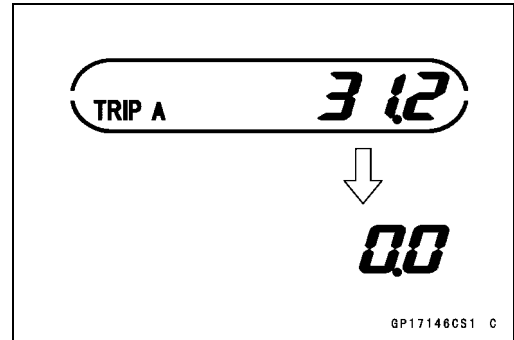
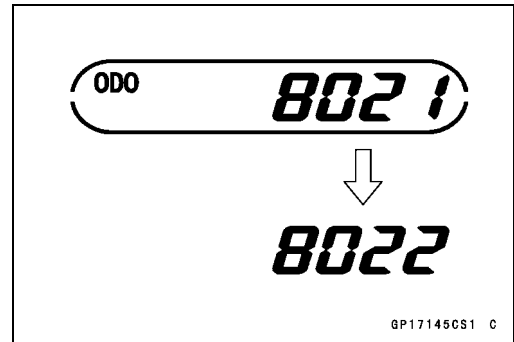

Meter, Gauge

Lights (LED) Inspection

- Connect the 12 V battery and terminals in the same manner as specified in the “Liquid Crystal Display (LCD) Segments check”.
- FI Indicator Light (LED) [A]
- Illumination Light (LED) [B]
- Fuel Level Warning Indicator Light (LED) [C]
- Water Temperature Warning Indicator Light (LED) [D]
- High Beam Indicator Light (LED) [E]
- Neutral Indicator Light (LED) [F]
- Turn Signal Indicator Light [G]

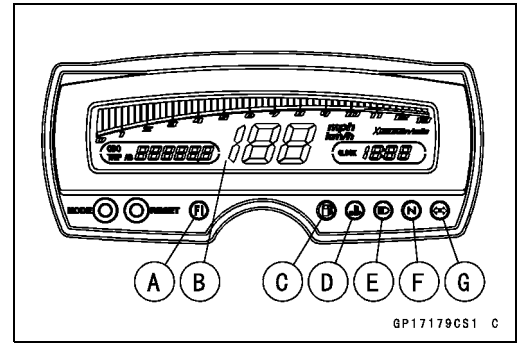

Illumination Light (LED) Inspection

- Connect the 12 V battery and terminals in the same manner as specified in the “Liquid Crystal Display (LCD) Segments check”.
- When the terminals are connected, the illumination light (LED) should go on.
- ★ If the illumination light (LED) does not go on, replace the meter assembly.

Neutral Indicator Light (LED) Inspection

- Connect the 12 V battery and terminals in the same manner as specified in the “Liquid Crystal Display (LCD) Segments check”.
- Using the insulated auxiliary lead, 12 V battery to the meter unit connector as follows.
- Connect the battery negative (–) terminal to the terminal [9].
- When the terminals are connected, the neutral indicator light (LED) should go on.
- ★ If the neutral indicator light (LED) does not go on, replace the meter assembly.

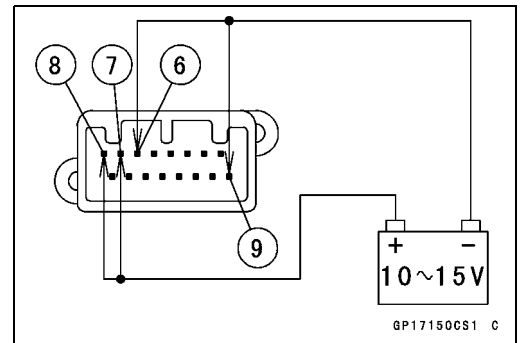

Water Temperature Warning Indicator Light (LED)

- Connect the 12 V battery and terminals in the same manner as specified in the “Liquid Crystal Display (LCD) Segments check”.
- Using the insulated auxiliary lead, 12 V battery to the meter unit connector as follows.
- Connect the battery negative (–) terminal to the terminal [13].

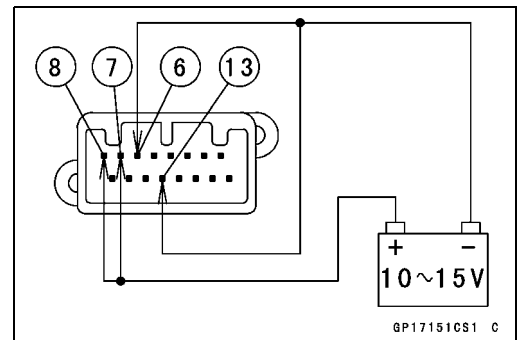

- ★ If the warning indicator light does not go on, replace the meter assembly.

16-78 ELECTRICAL SYSTEM

Meter, Gauge

Right and Left Turn Signal Indicator Light (LED)

- Connect the 12 V battery and terminals in the same manner as specified in the “Liquid Crystal Display (LCD) Segments check”.
- Using the insulated auxiliary leads, 12 V battery to the meter unit connector as follows.
- Connect the battery positive (+) terminal to the terminal [11].
- Connect the battery positive (+) terminal to the terminal [12].

- When the terminals are connected, the turn signal indicator light (LED) should go on.
- ★ If the turn signal indicator light (LED) does not go on, replace the meter assembly.

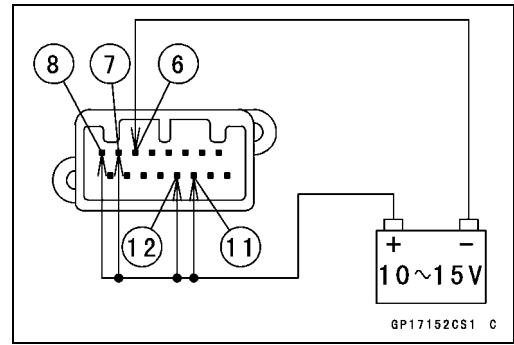

High Beam Indicator Light (LED)

- Connect the 12 V battery and terminals in the same manner as specified in the “Liquid Crystal Display (LCD) Segments check”.
- Using the insulated auxiliary lead, 12 V battery to the meter unit connector as follows.
- Connect the battery positive (+) terminal to the terminal [10].

- When the terminals are connected, the high beam indicator light (LED) should go on.
- ★ If the turn signal high beam indicator light (LED) does not go on, replace the meter assembly.

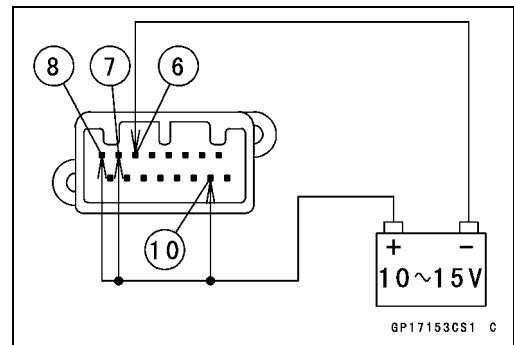

Fuel Level Warning Indication Light (LED)

- Connect the 12 V battery and terminals in the same Manner as specified in the “Liquid Crystal Display (LCD) Segments check”.
- Connect the variable rheostat [A] to the terminal [16] as shown in the figure.
- Adjust the resistance value to the approximately 20 Ω.

- When the terminals are connected, the fuel level warning indicator light (LED) [A] should go on and FUEL segment [B] blinks in the display.
- ★ If the fuel level warning indicator light (LED) does not go on or FUEL segment do not appear, replace the meter assembly.

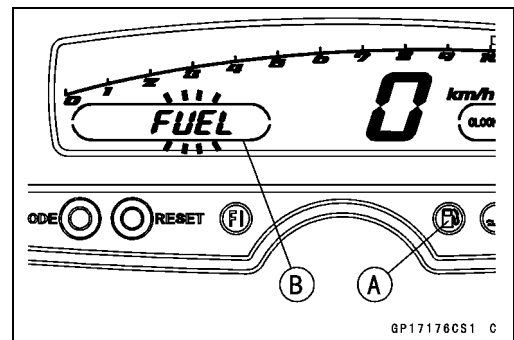
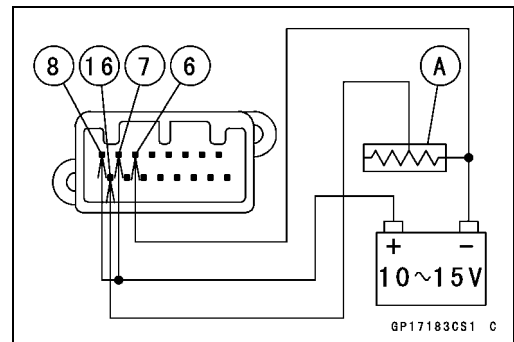

Meter, Gauge

- Disconnect the terminal [16].
- When the terminals are disconnected, the fuel level warning indicator light (LED) [A] blinks and FUEL segment [B] blinks by display.
- ★ If the fuel level warning indicator light (LED) does not blink or FUEL segment do not display, replace the meter unit.

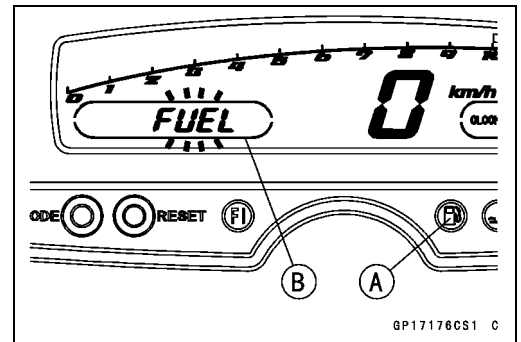

- Connect the battery negative (-) terminal to the terminal [16].
- When the terminals are connected, the fuel level warning indicator light (LED) blinks and FUEL segment blinks by display.
- ★ If the fuel level warning indicator light (LED) does not blink or FUEL segment do not display, replace the meter unit.

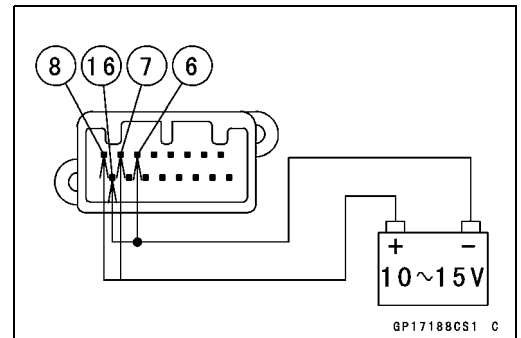

FI Indicator Light (LED)

- Connect the 12 V battery and terminals in the same Manner as specified in the "Liquid Crystal Display (LCD) Segments check".
- Using the insulated auxiliary lead, 12 V battery to the meter unit connector as follows.
- Connect the battery negative (-) terminal to the terminal [14].

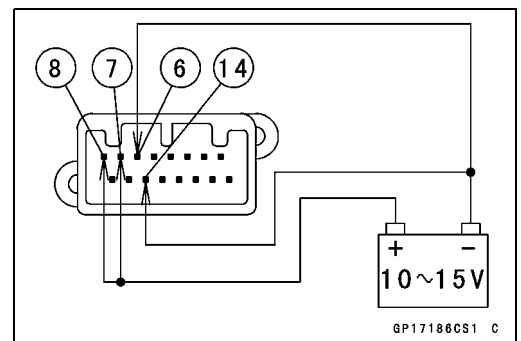

- When the terminals are connected, the FI indicator light (LED) [A] should go on.
- ★ If the FI indicator light (LED) does not go on, replace the meter unit.

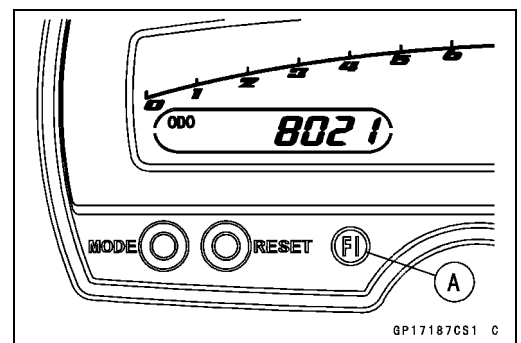

16-80 ELECTRICAL SYSTEM

Meter, Gauge

Meter Unit Circuit

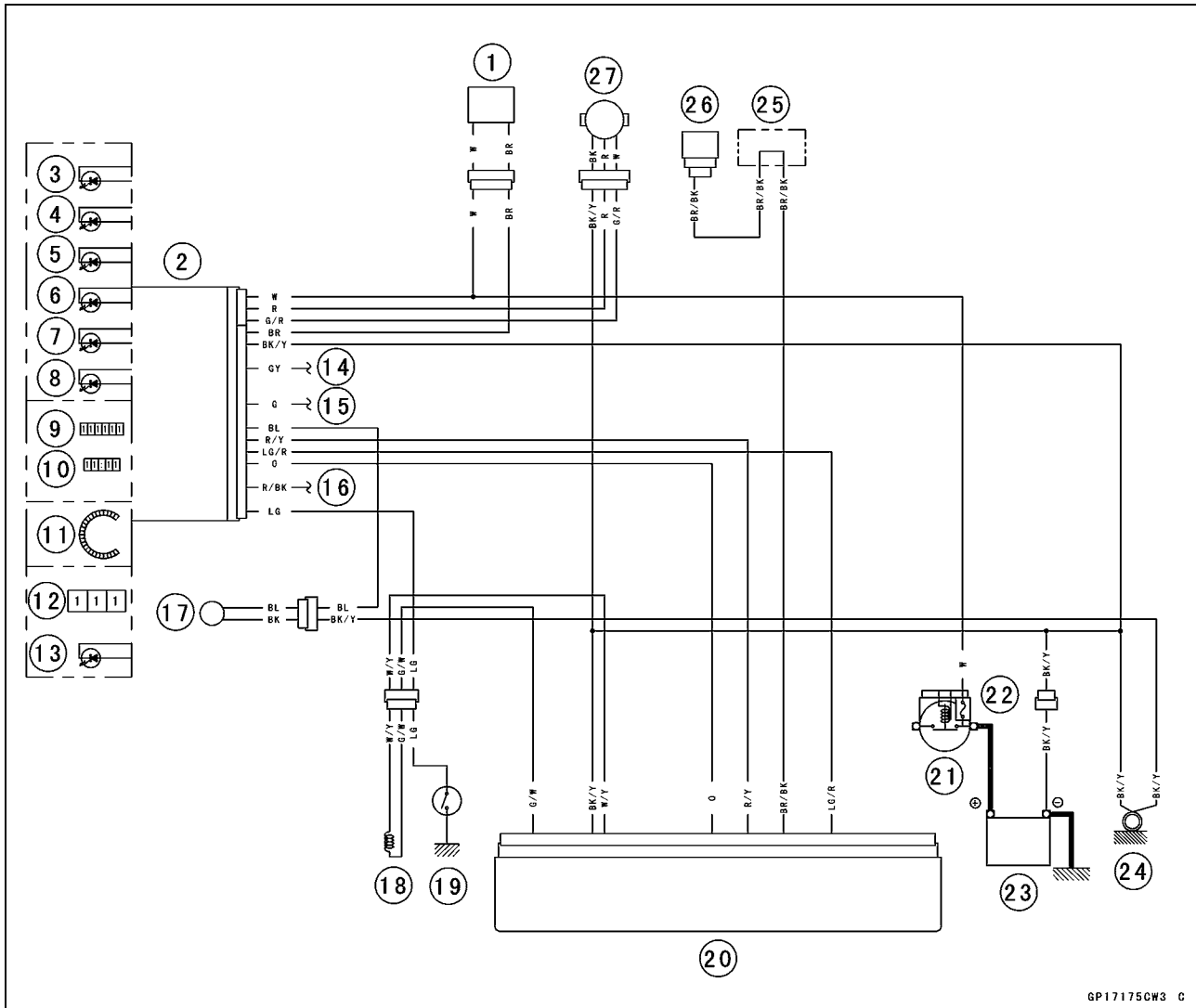

GP17175CW3 C

- | | |
|--|-------------------------------|
| 1. Ignition Switch | 15. Turn Signal Switch (Left) |
| 2. Meter Unit | 16. Dimmer Switch (High Beam) |
| 3. Turn Signal Indicator Light (LED) | 17. Fuel Reserve Switch |
| 4. High Beam Indicator Light (LED) | 18. Crankshaft Sensor |
| 5. Neutral Indicator Light (LED) | 19. Neutral Switch |
| 6. Water Temperature Warning Light (LED) | 20. ECU |
| 7. FI Indicator Light (LED) | 21. Starter Relay |
| 8. Fuel Level Warning Light (LED) | 22. Main Fuse 20 A |
| 9. Odometer/Trip Meter | 23. Battery 12 V 6 Ah |
| 10. Clock | 24. Frame Ground |
| 11. Tachometer | 25. Water-proof Joint |
| 12. Speedometer | 26. Water Temperature Sensor |
| 13. Meter Light (LED) | 27. Speed Sensor |
| 14. Turn Signal Switch (Right) | |

Switches and Sensors

Water Temperature Sensor Inspection

- Remove the water temperature sensor (see Water Temperature Sensor Removal/Installation in the Fuel System (DFI) chapter).
- Suspend the sensor [A] in a container of machine oil so that the heat-sensitive portion and threaded portion are submerged.
- Suspend an accurate thermometer [B] with heat-sensitive portions [C] located in almost the same depth.

NOTE

- *The sensor and thermometer must not touch the container side or bottom.*
- Place the container over a source of heat and gradually raise the temperature of the oil while stirring the oil gently for even temperature.
- Using the hand tester, measure the internal resistance of the sensor.
- ★ If the measurement is out of the range, replace the sensor.

Water Temperature Sensor Resistance

Temperature	Resistance (k Ω)
-20°C (-4°F)	*18.80 \pm 2.37
0°C (32°F)	*(About 6.544)
40°C (104°F)	1.136 \pm 0.095
100°C (212°F)	0.1553 \pm 0.0070

*: Reference Information

Speed Sensor Removal

- Remove:
 - Headlight Body (see Headlight Body Removal)
- Disconnect the speed sensor connector [A].
- Remove the bolt [A] to free the speed sensor lead from the clamp [B] at the steering stem base.

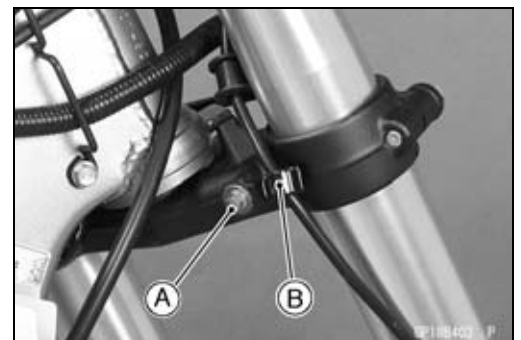
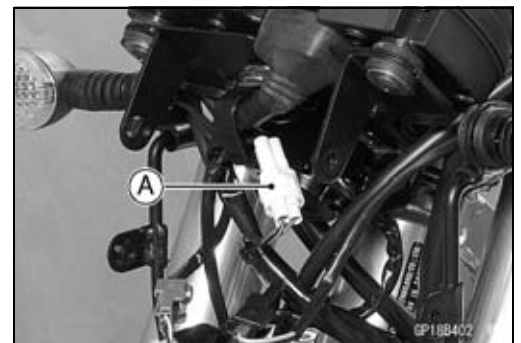
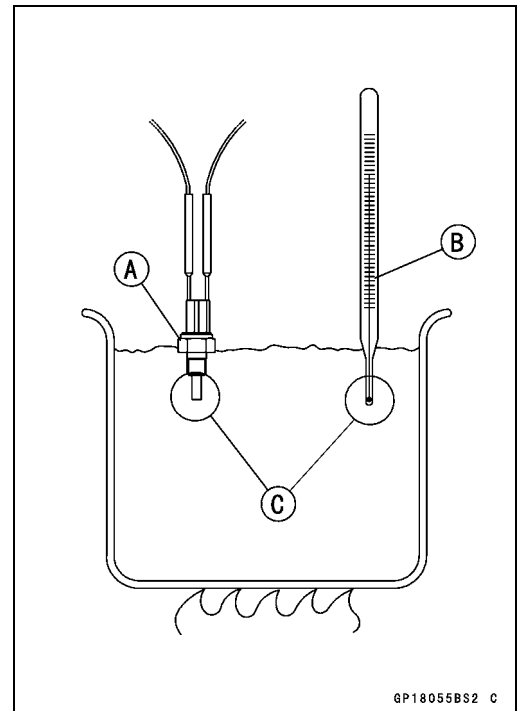

16-82 ELECTRICAL SYSTEM

Switches and Sensors

- Remove the speed sensor lead from the clamps [A] at the fork protector.
- Remove:
 - Front Wheel (see Front Wheel Removal in the Wheels/Tires chapter)
 - Speed Sensor [B]

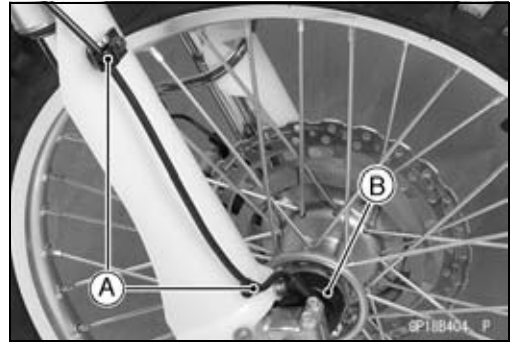

Speed Sensor Installation

- Apply grease to the speed sensor seal lip [A].
- Install the speed sensor so that grooves [B] of the speed sensor fit the projections [C] of the front hub.
- After installing it, lightly turn the speed sensor housing left and right by half a turn to check if the projection of hub are engaged properly in the grooves provided on the speed sensor.

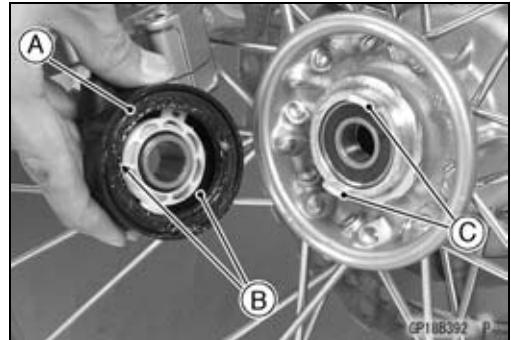

- When they are installed properly [A], no gaps [D] should be observed between the wheel [B] and the housing [C]. If there is a gap [F] between the wheel and the housing, then they are not engaged properly [E].

NOTICE

Unless the speed sensor housing is properly installed on the wheel, you will damage the speed sensor rotor in tightening the front axle.

- Install the front wheel (see Front Wheel Installation in the Wheels/Tires chapter).

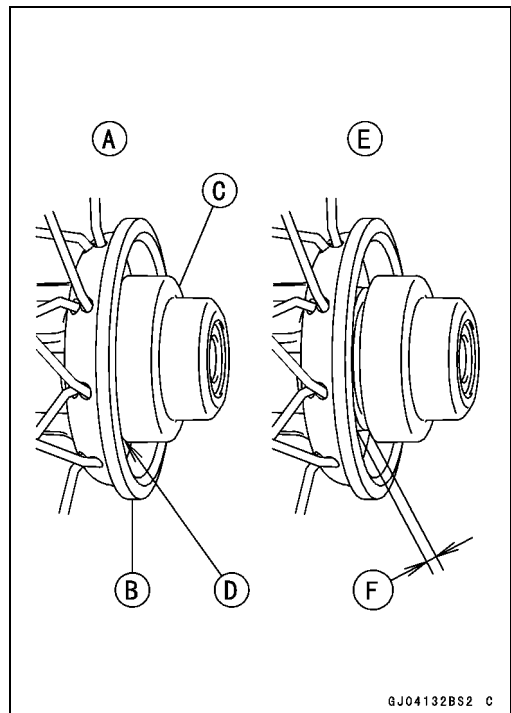

Speed Sensor Inspection

- Refer to the Speed Sensor Inspection in the Fuel System (DFI) chapter.

Switches and Sensors

Fuel Reserve Switch Inspection

- Fill the fuel tank with fuel.
- Close the fuel tank cap surely.
- Remove:
 - Right Side Cover (see Side Cover Removal in the Frame chapter)
 - Fuel Pump Lead Connector
- Connect the test light [A] (12 V 3.4 W bulb in a socket with leads) and the 12 V battery [B] to the fuel level sensor lead connector [C].

Special Tool - Needle Adapter Set: 57001-1457

Connections

- Battery (+) → 12 V 3.4 W Bulb (one side)
- 12 V 3.4 W Bulb (other side) → BL Lead Terminal
- Battery (-) → BK Lead Terminal

- ★ If the test light turn on, the reserve switch is defective. Replace the fuel pump.

- Remove:
 - Fuel Pump (see Fuel Pump Removal in the Fuel System (DFI) chapter)
- Connect the test light (12 V 3.4 W bulb in a socket with leads) and the 12 V battery to the fuel pump lead connector as shown.
 - 12 V Battery [A]
 - Test Light [B]
 - Fuel Pump Lead Connector [C]
 - Fuel Reserve Switch [D]

- ★ If the test light doesn't light, replace the fuel pump.

NOTE

○ It may take a long time to turn on the test light in case that the fuel reserve switch is inspected just after the fuel level sensor is removed.

Leave the fuel reserve switch with leads for inspection connected for few minutes.

Oxygen Sensor Removal

- Remove:
 - Turn Signal Light Relay [A]
- Disconnect the oxygen sensor lead connectors [B].
- Pull out the oxygen sensor lead connector to the outside of the motorcycle.
- Remove the band [C] as necessary.

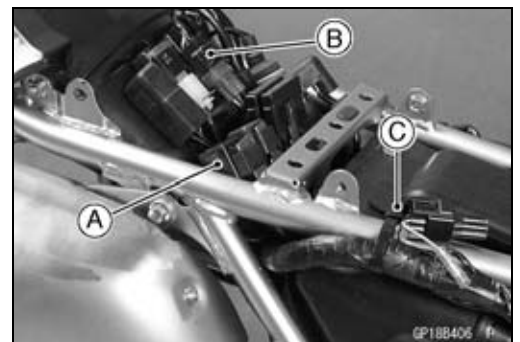
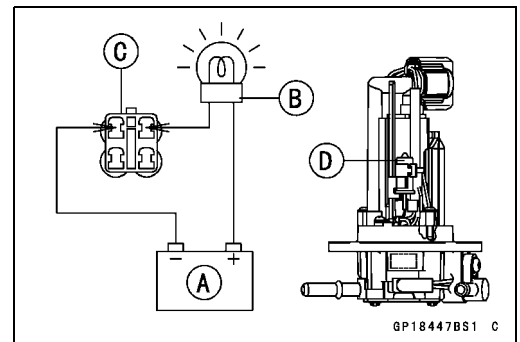
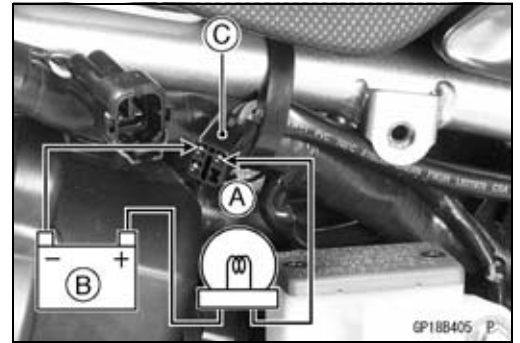

16-84 ELECTRICAL SYSTEM

Switches and Sensors

- Remove the oxygen sensor [A].

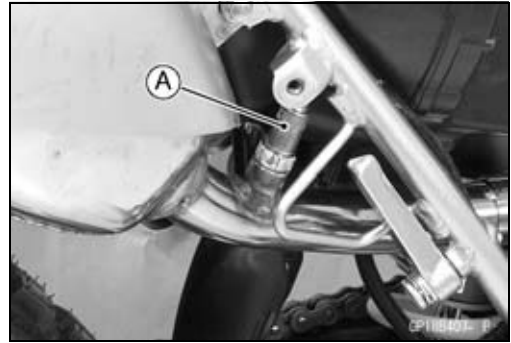

Oxygen Sensor Installation

NOTICE

Never drop the Oxygen Sensor [A] especially on a hard surface. Such a shock to the unit can damage it.
Do not touch the sensing part [B] to prevent oil contact. Oil contamination from hands can reduce sensor performance.

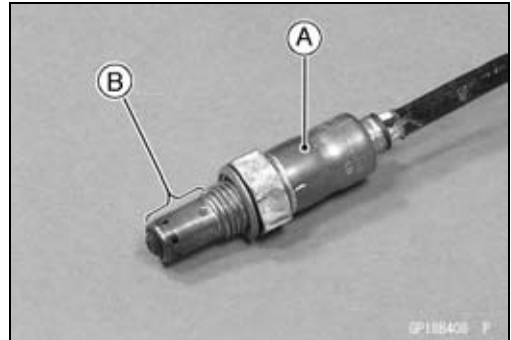

- Tighten:
Torque - Oxygen Sensor: 25 N·m (2.5 kgf·m, 18 ft·lb)
- Run the oxygen sensor lead correctly (see Cable, Wire and Hose Routing section in the Appendix chapter).

Oxygen Sensor Inspection

- Refer to the Oxygen Sensor Inspection in the Fuel System (DFI) chapter.

Oxygen Sensor Heater Inspection

- Refer to the Oxygen Sensor Heater Inspection in the Fuel System (DFI) chapter.

Sidestand Switch Removal

- Remove:
Left Side Cover (see Side Cover Removal in the Frame chapter)
Bolts [A]
Vehicle-down Sensor Bracket[B]

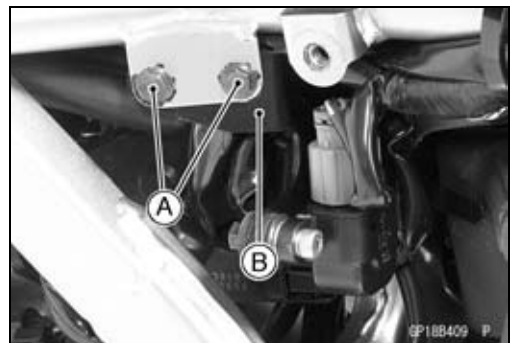

Switches and Sensors

- Remove:
 - Subthrottle Sensor Connector [A]
 - Bands [B]
 - Sidestand Switch Connector [C]

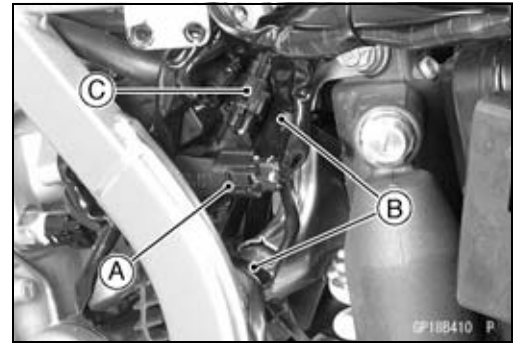

- Remove:
 - Bolt [A]
 - Sidestand Switch Cover [B]
 - Sidestand Switch [C]

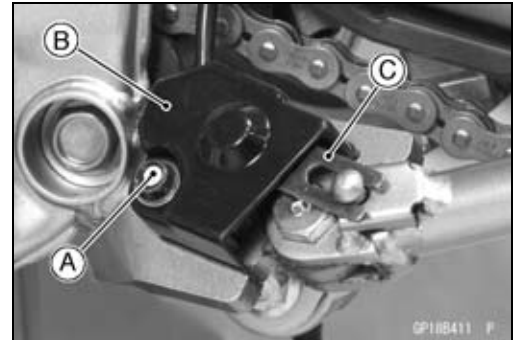

Sidestand Switch Installation

- Install the sidestand switch (see Sidestand Installation in the Frame chapter).
- Apply a non-permanent locking agent to the sidestand switch mounting bolts, and tighten it.
 - Torque - Sidestand Switch Mounting Bolt: 8.8 N·m (0.90 kgf·m, 78 in·lb)**
- Hold the sidestand switch lead on the frame brackets [A] (see Cable, Wire and Hose Routing in the Appendix chapter).
- Connect the sidestand switch lead connector.

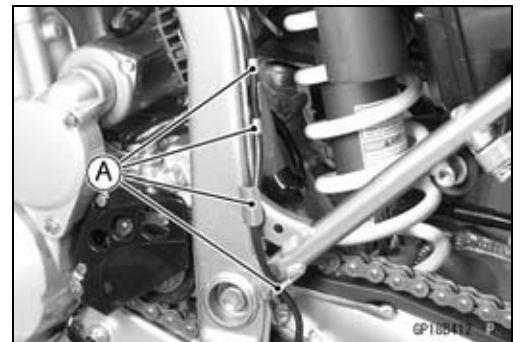

Brake Light Timing Inspection

- Refer to the Brake Light Switch Operation Inspection in the Periodic Maintenance chapter.

Brake Light Timing Adjustment

- Refer to the Brake Light Switch Operation Inspection in the Periodic Maintenance chapter.

16-86 ELECTRICAL SYSTEM

Switches and Sensors

Switch Inspection

- Using a hand tester, check to see that only the connections shown in the table have continuity.

Special Tool - Hand Tester: 57001-1394

○ For the switch housings and the ignition switch, refer to the tables in the Wiring Diagram.

- ★ If the switch has an open or short, repair it or replace it with a new one.

Rear Brake Light Switch Connections

Rear Brake Light Switch Connections		
Color	BR	BK
When brake pedal is pushed down	○ —	○ —
When brake pedal is released		

Sidestand Switch Connections

Sidestand Switch Connections		
Color	BK	G
When sidestand is down		
When sidestand is up	○ —	○ —

Neutral Switch Connections

Neutral Switch Connections		
Color	SW. Terminal	Ground
When transmission is in neutral	○ —	○ —
When transmission is not in neutral		

Fuse

20 A Main Fuse Removal

- Remove the seat (see Seat Removal in the Frame chapter).
- Disconnect the starter relay connector [A].



- Pull out the main fuse [A] from the starter relay with needle nose pliers.



Fuse Box Fuse Removal

- Remove the seat (see Seat Removal in the Frame chapter).
- Unlock the hooks [A] to lift up the lids [B].

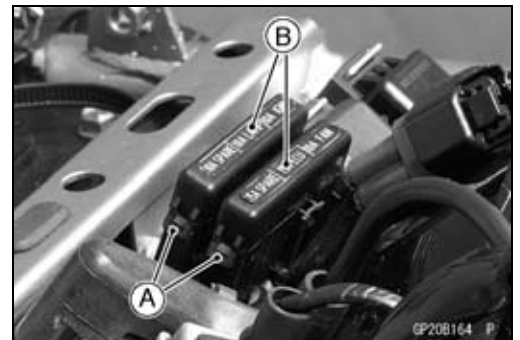

- Pull the fuses [A] straight out of the fuse box with needle nose pliers.

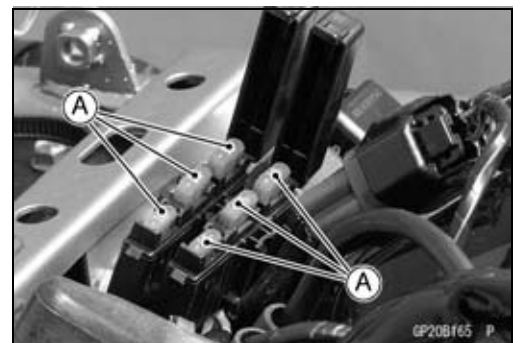

Fuse Installation

- If a fuse fails during operation, inspect the electrical system to determine the cause, and then replace it with a new fuse of proper amperage.
- Install the fuse box fuses on the original position as specified on the lid.

16-88 ELECTRICAL SYSTEM

Fuse

Fuse Inspection

- Remove the fuse (see 20 A Main Fuse/Fuse Box Fuse Removal).
- Inspect the fuse element.
- ★ If it is blown out, replace the fuse. Before replacing a blown fuse, always check the amperage in the affected circuit. If the amperage is equal to or greater than the fuse rating, check the wiring and related components for a short circuit.

Housing [A]

Fuse Element [B]

Terminals [C]

Blown Element [D]

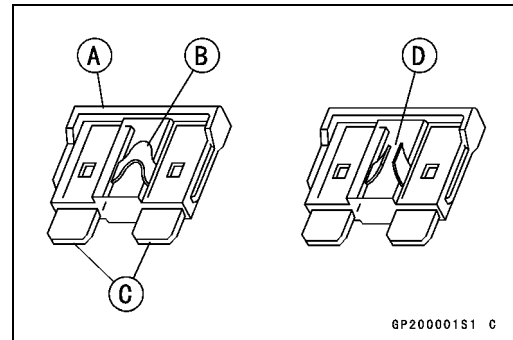

NOTICE

When replacing a fuse, be sure the new fuse matches the specified fuse rating for that circuit. Installation of a fuse with a higher rating may cause damage to wiring and components.

Appendix

Table of Contents

Cable, Wire, and Hose Routing	17-2
Troubleshooting Guide	17-28

17-2 APPENDIX

Cable, Wire, and Hose Routing

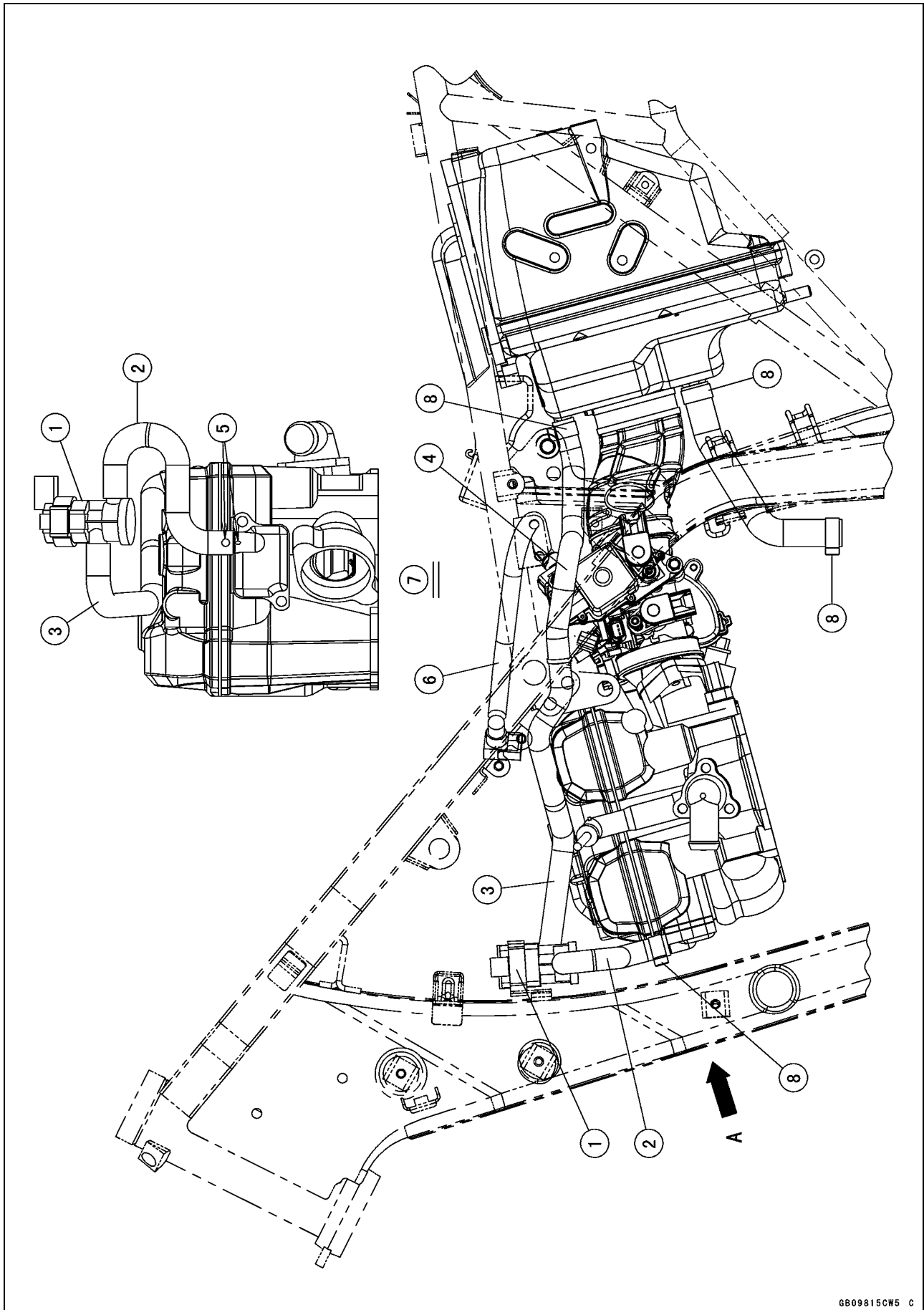

Cable, Wire, and Hose Routing

1. Air Switching Valve
2. Air Switching Valve Hose (To Air Suction Valve)
3. Air Switching Valve Hose (To Fitting)
4. Air Switching Valve Hose (To Air Cleaner Housing)
5. Align the white mark of the air switching valve hose and the mark of the air suction valve cover.
6. Fuel Hose (To Fuel Pump)
7. Viewed from A
8. Clamps (Set the tab of the clamp as shown in the figure.)

17-4 APPENDIX

Cable, Wire, and Hose Routing

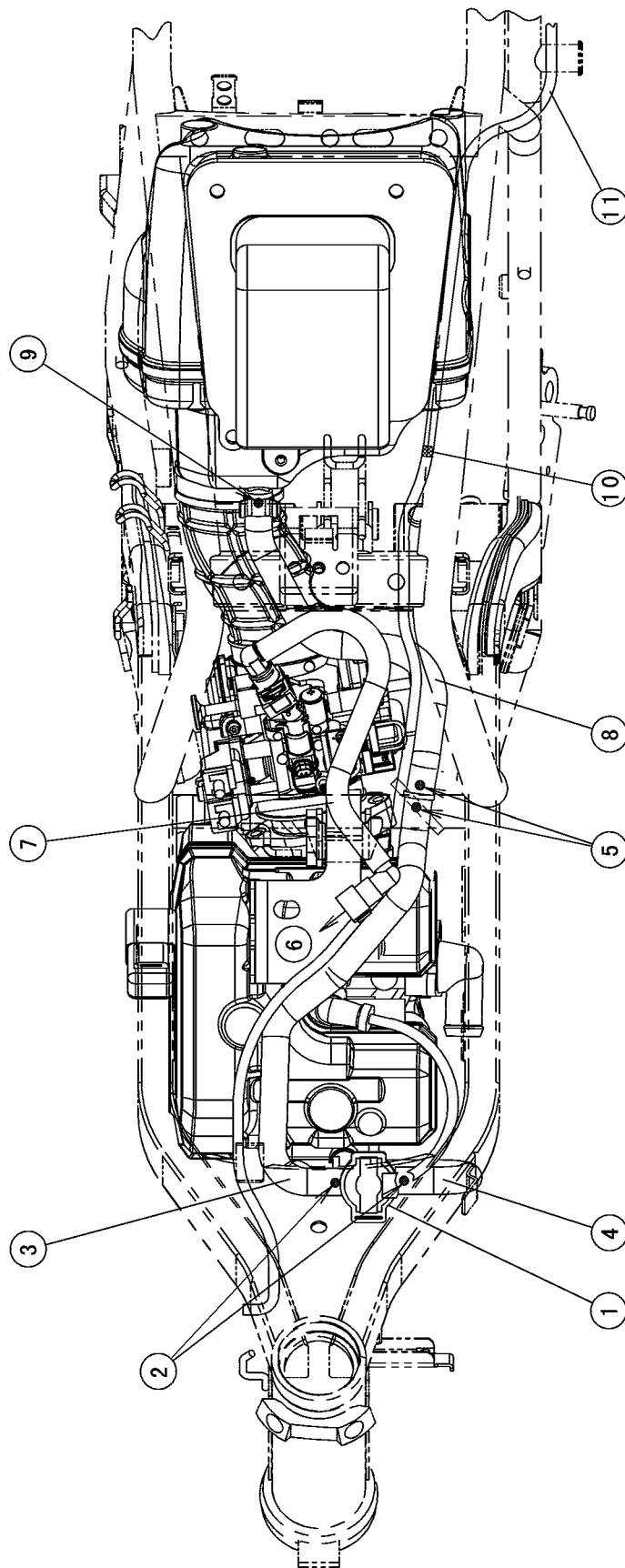

Cable, Wire, and Hose Routing

1. Air Switching Valve
2. Install the air switching valve hose to the air switching valve so that the white mark faces upper side.
3. Air Switching Valve Hose (To Fitting)
4. Air Switching Valve Hose (To Air Suction Valve)
5. Install the air switching valve hose to the fitting so that the white mark faces upper side.
6. To Fuel Pump
7. Fuel Hose
8. Air Switching Valve Hose (To Air Cleaner Housing)
9. Install the air switching valve hose to the air cleaner housing so that the white mark faces upper side.
10. White Tape
11. Reserve Tank Hose

17-6 APPENDIX

Cable, Wire, and Hose Routing

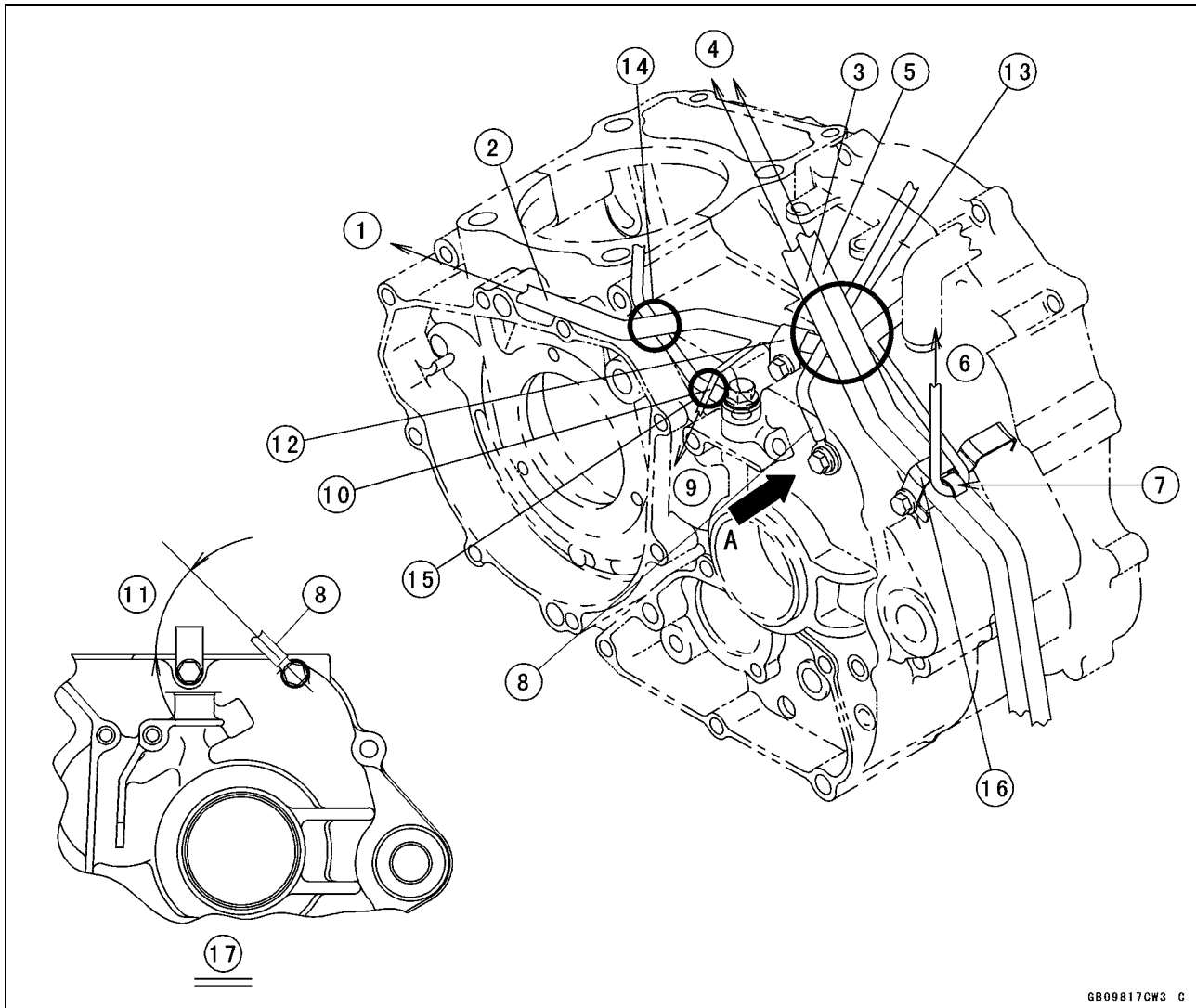

GB09817CW3 C

1. To Alternator Cover
2. Alternator/Crankshaft Sensor Lead
3. Fuel Tank Breather Hose
4. To Feul Tank
5. Fuel Tank Drain Hose
6. To Regulator/Rectifier
7. Run the regulator/rectifier lead to the bracket guide.
8. Engine Ground Cable
9. To Neutral Switch
10. Neutral Switch Lead
11. 45°
12. Clamp (Clamp the alternator/crankshaft sensor lead.)
13. Run the engine ground cable under the fuel tank breather hose and fuel tank drain hose.
14. Run the alternator/crankshaft sensor lead over the oil pipe.
15. Run the neutral switch lead over the oil pipe.
16. Clamp (Run the fuel tank breather hose and fuel tank drain hose to the clamp).
17. Viewed from A

Cable, Wire, and Hose Routing

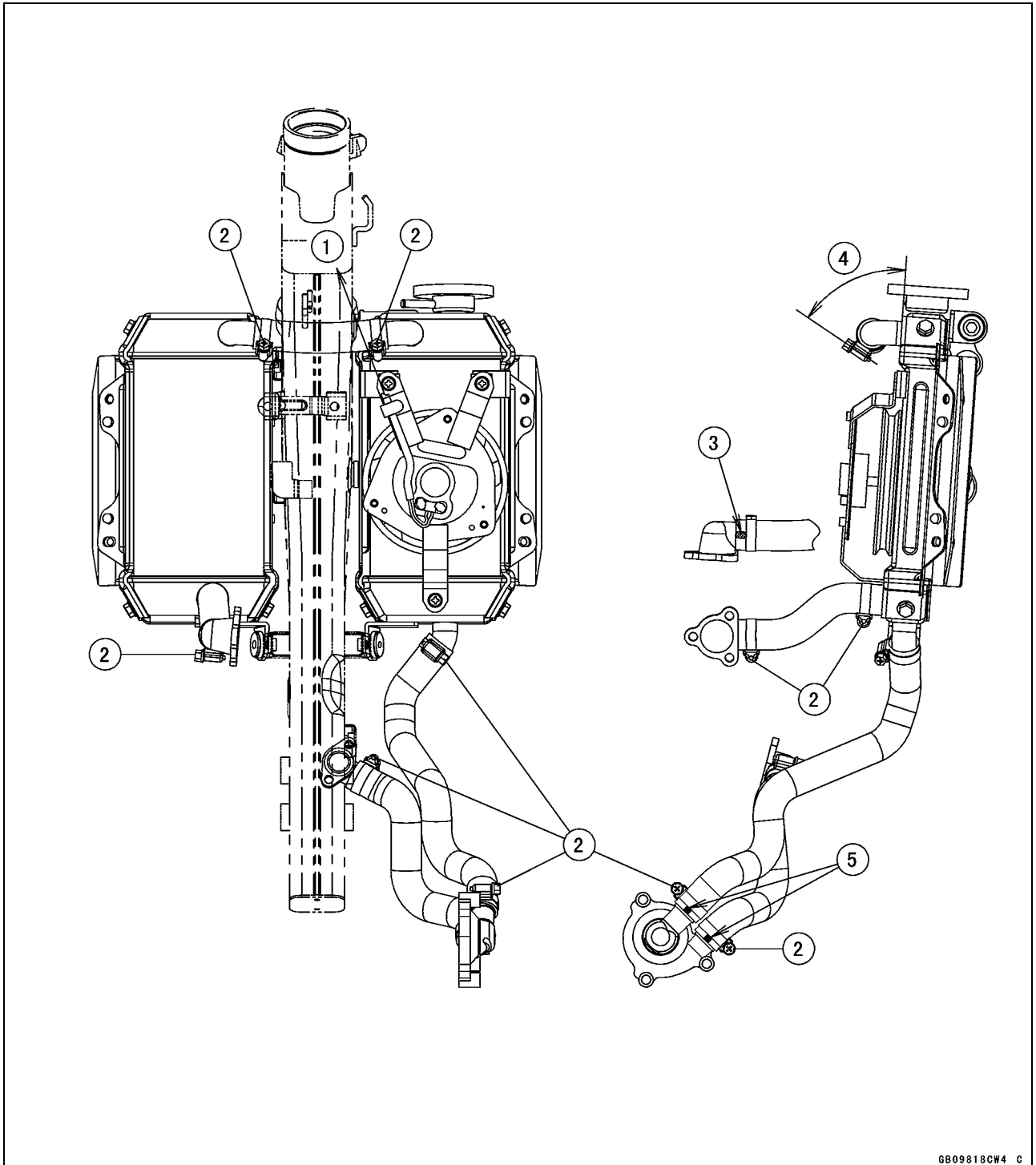

GB09818CW4 C

1. To Main Harness
2. Clamps (Set the bolt head of the clamp as shown in figure.)
3. Face the white mark upper side.
4. About 60°
5. Face the white mark right side.

17-8 APPENDIX

Cable, Wire, and Hose Routing

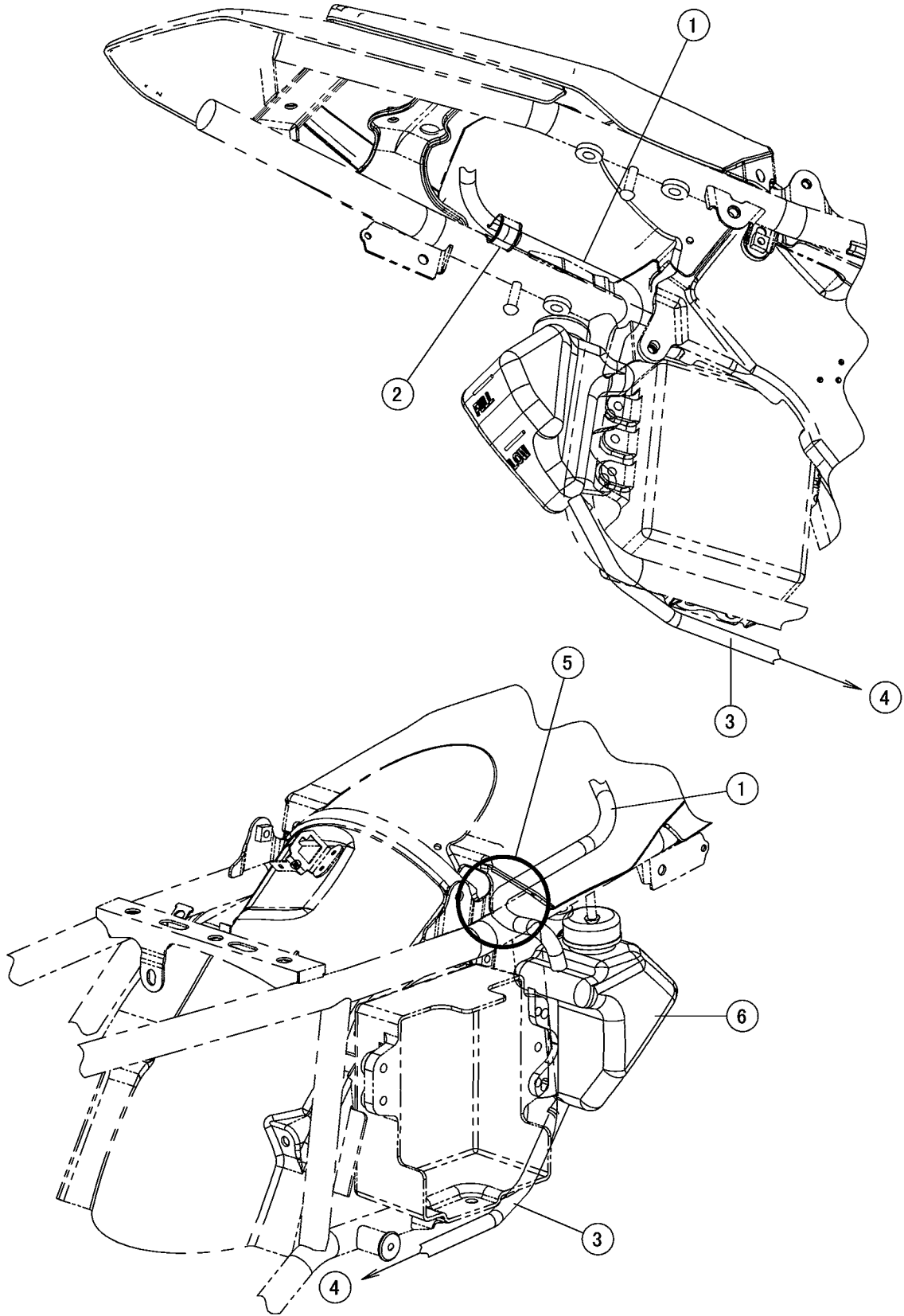

Cable, Wire, and Hose Routing

1. Reserve Tank Overflow Hose
2. Clamp (Run the reserve tank overflow hose to the clamp on the frame.)
3. Reserve Tank Hose
4. To Radiator
5. Run the reserve tank overflow hose between the rear fender rear and frame.
6. Reserve Tank

17-10 APPENDIX

Cable, Wire, and Hose Routing

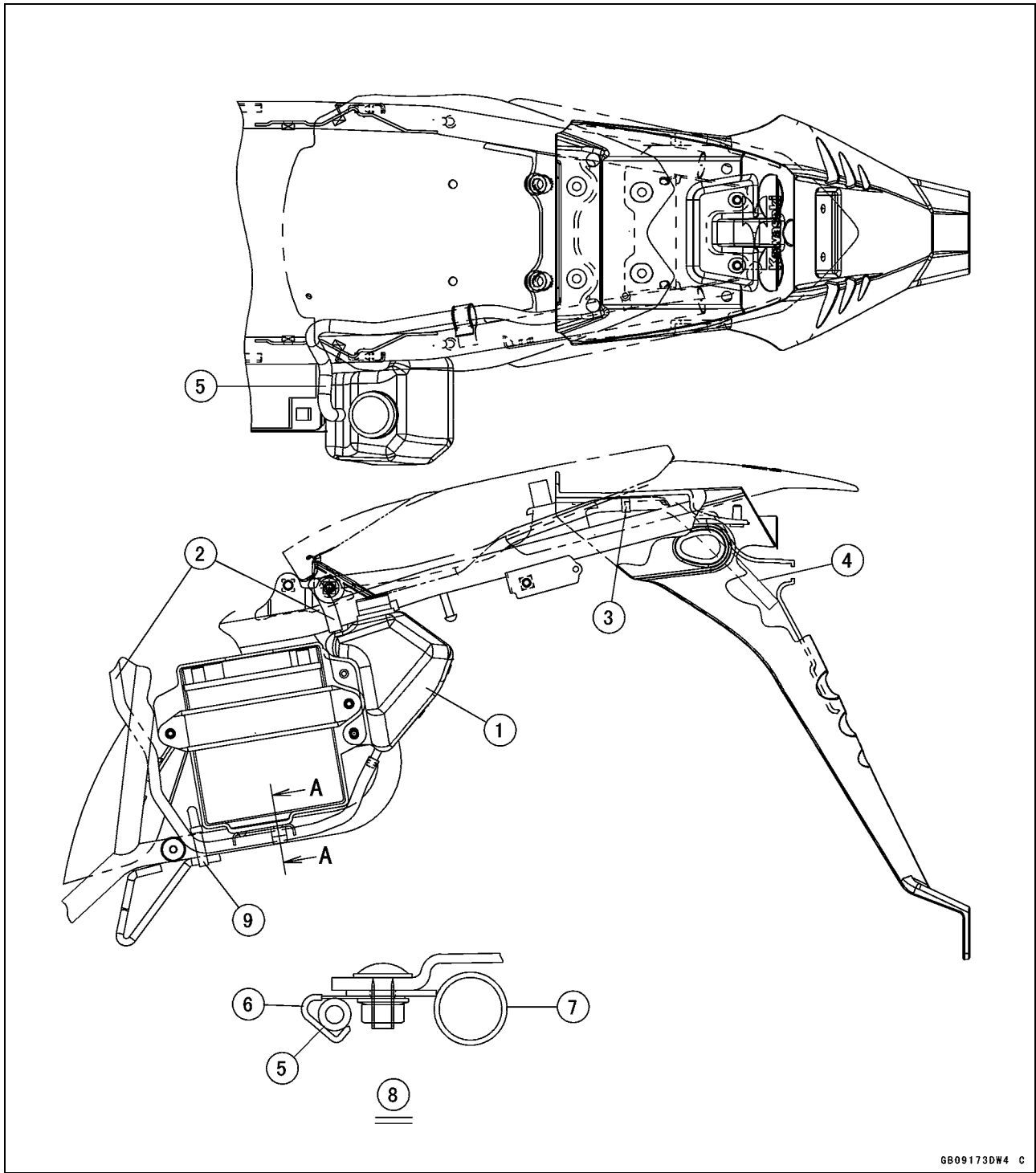

1. Reserve Tank
2. Reserve Tank Overflow Hose
3. Clamp
4. Install the overflow hose so that the hose end is along the inside of the rear flap.
5. Reserve Tank Hose
6. Clamp (Bend the clamp to hold the reserve tank hose as shown in the figure.)
7. Frame Pipe
8. Viewed from A-A

Cable, Wire, and Hose Routing

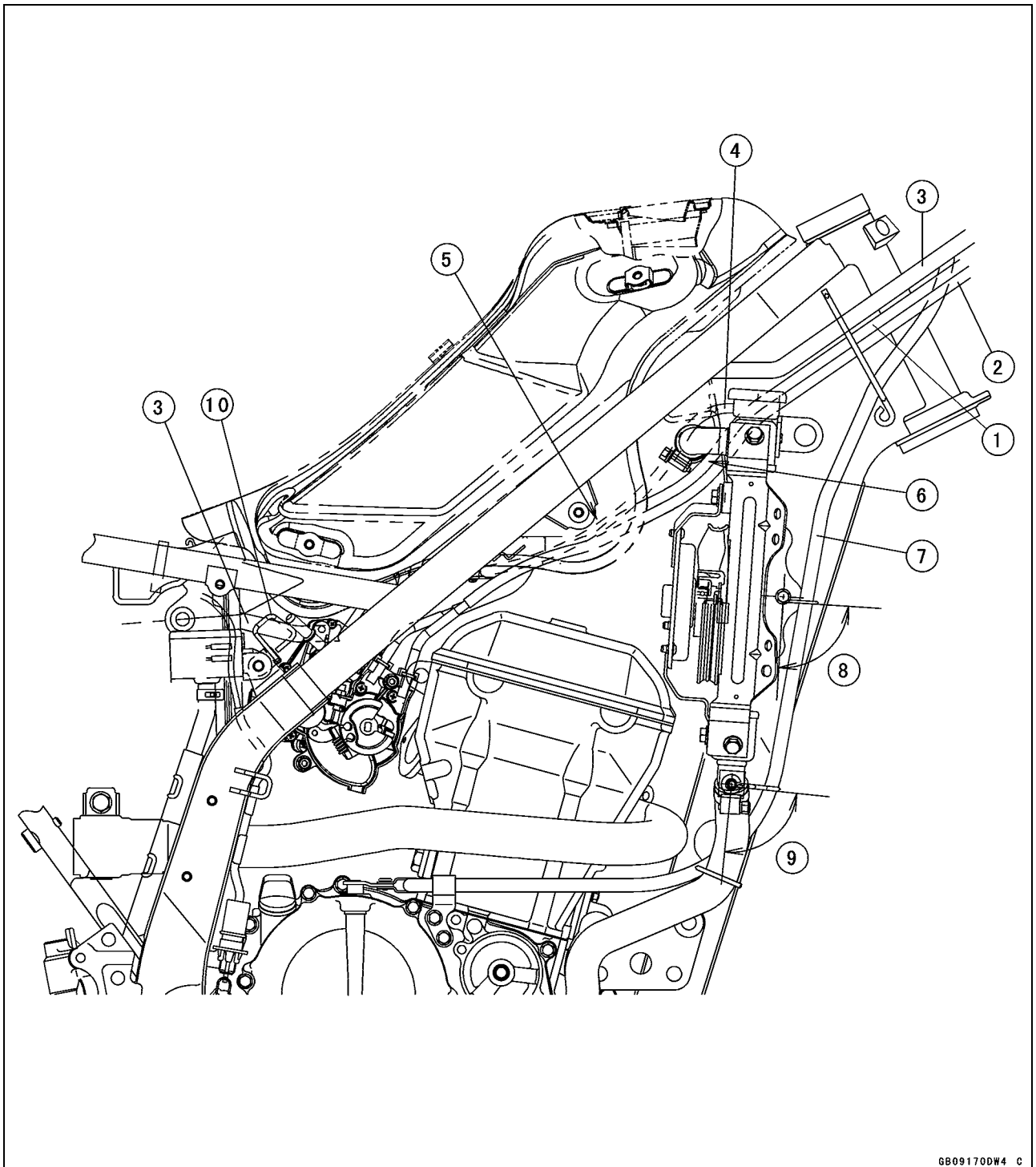

GB09170DW4 C

1. Throttle Cable (Decelerator)
2. Throttle Cable (Accelerator)
3. Main Harness
4. Reserve Tank Hose
5. Run the throttle cables and reserve tank hose inside of the fuel tank.
6. Run the throttle cables under the radiator hose.
7. Clutch Cable
8. About 90°
9. About 90°
10. Clamp (Run the main harness to the clamp).

17-12 APPENDIX

Cable, Wire, and Hose Routing

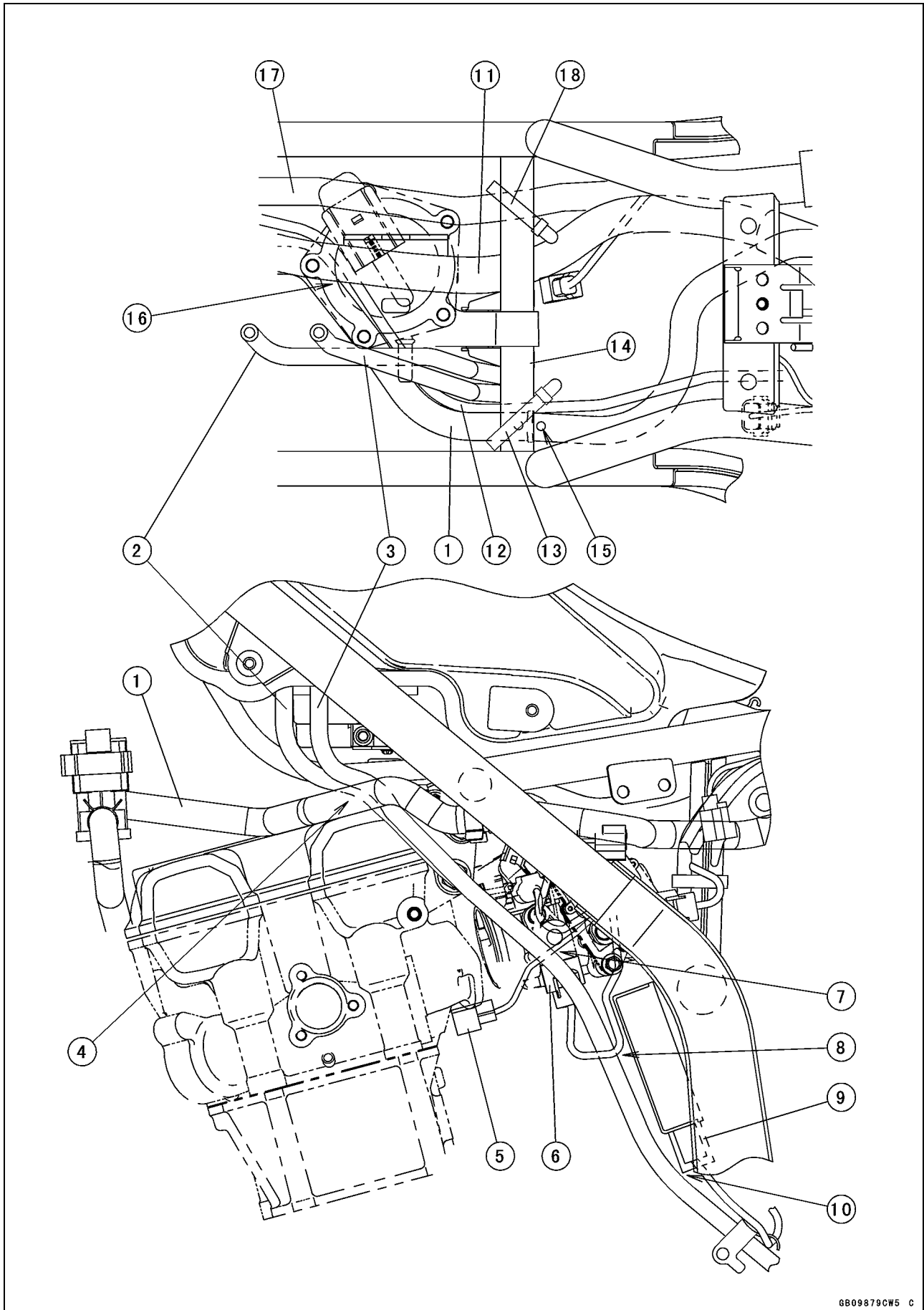

Cable, Wire, and Hose Routing

1. Air Switching Valve Hose
2. Fuel Tank Breather Hose
3. Fuel Tank Drain Hose
4. Run the fuel tank breather and drain hose inside of the air switching valve hose.
5. Water Temperature Sensor
6. Main Throttle Sensor
7. Run the fuel tank breather hose and drain hose outside of the water temperature sensor lead.
8. Run the fuel tank breather hose and drain hose inside of the main throttle sensor lead.
9. Regulator/Rectifier Connector Cover
10. Run the fuel tank breather hose and drain hose so that they do not crush the cover with the hoses.
11. Main Harness
12. Reserve Tank Hose
13. Band (Clamp the air switching valve hose and reserve tank hose.)
14. Frame Cross Pipe
15. Connect the air switching valve hose at the back of the frame cross pipe so that the white mark faces upper side.
16. Run the air switching valve hose and reserve tank hose under the main harness.
17. Green/White Hose (SEA and TH Models only).
18. Band (clamp the green/white hose.) (SEA and TH Models only)

17-14 APPENDIX

Cable, Wire, and Hose Routing

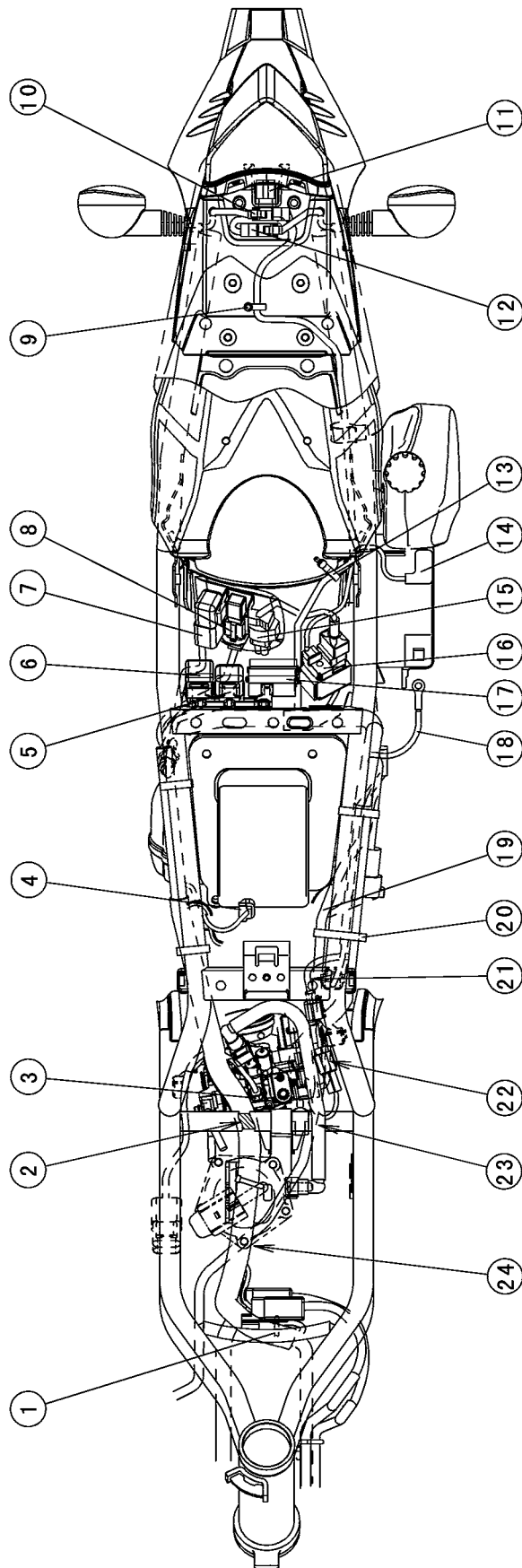

Cable, Wire, and Hose Routing

1. Align the white mark of the main harness and the frame hook.
2. Run the main harness under the frame cross pipe. Align the white mark to the frame cross pipe.
3. Fuel Injector
4. Inlet Air Temperature Sensor
5. Fan Relay
6. Turn Signal Relay
7. Starter Circuit Relay
8. Interlock Diode Unit
9. Clamp (Clamp the main harness.)
10. Rear Right Turn Signal Light Connector
11. Tail/Brake Light Connector
12. Rear Left Turn Signal Light Connector
13. Clamp (Clamp the main harness. Do not clamp the reserve tank hose.)
14. Battery Positive (+) Cable
15. Oxygen Sensor Connector
16. Starter Relay
17. Fuse Box
18. Battery Negative (-) Cable
19. Reserve Tank Hose
20. Band (Clamp the reserve tank hose.)
21. Run the reserve tank hose under the frame bracket.
22. Run the subthrottle valve actuator lead under the air switching valve hose.
23. Run the reserve tank hose under the frame cross pipe.
24. Run the reserve tank hose under the main harness.

17-16 APPENDIX

Cable, Wire, and Hose Routing

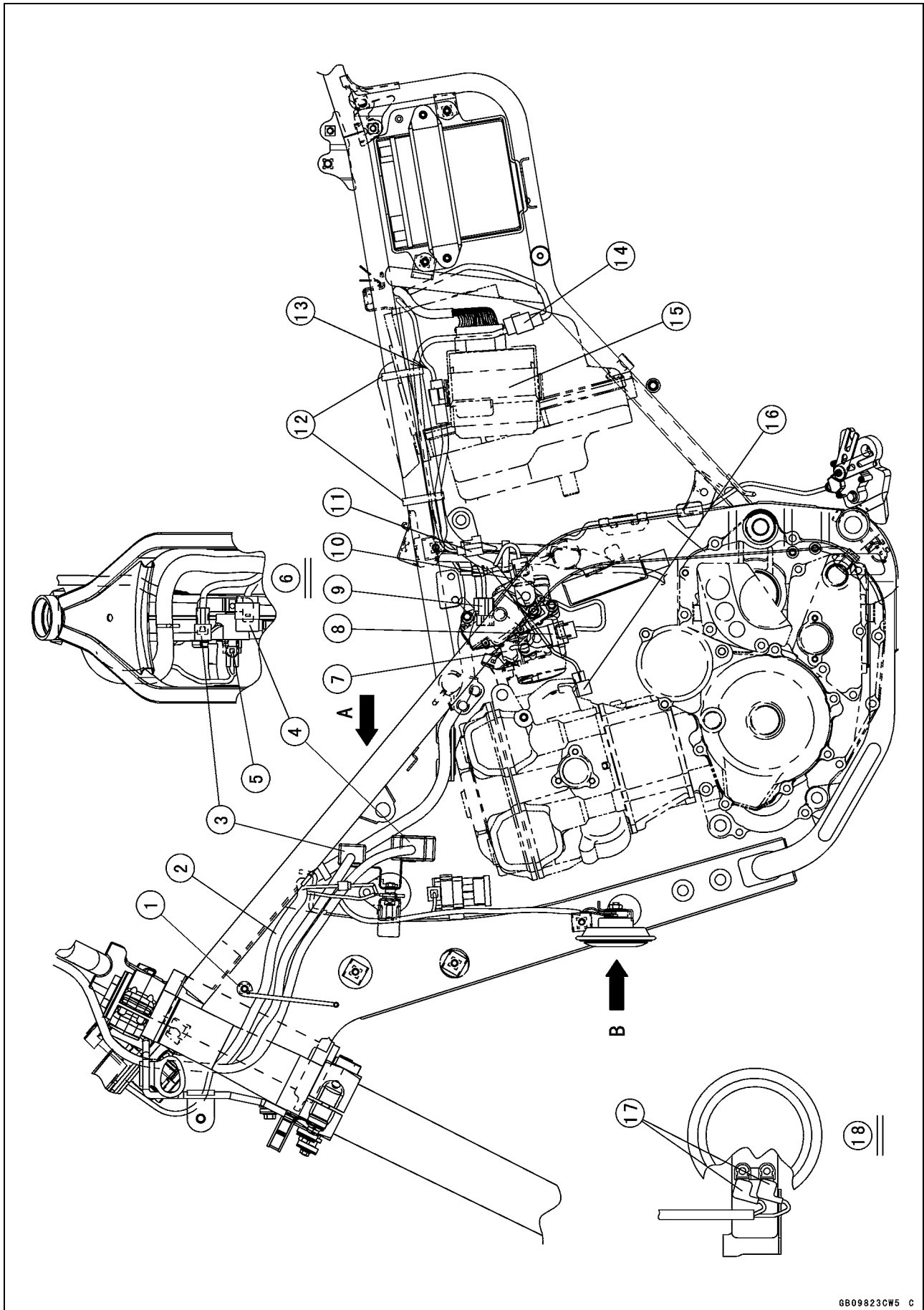

Cable, Wire, and Hose Routing

1. Guide (Run the left and right switch housing leads and reserve tank hose to the guide.)
2. Reserve Tank Hose
3. Right Switch Housing Connector
4. Left Switch Housing Connector
5. Frame Ground Terminal
6. Viewed from A
7. Inlet Air Pressure Sensor
8. Main Throttle Sensor
9. Subthrottle Valve Actuator
10. Subthrottle Sensor
11. Vehicle-down Sensor
12. Band (Clamp the starter motor cable, alternator lead, reserve tank hose and main harness.)
13. Do not clamp the crankshaft sensor lead.
14. Alternator Connector
15. ECU
16. Water Temperature Sensor
17. Horn Connectors
18. Viewed from B

17-18 APPENDIX

Cable, Wire, and Hose Routing

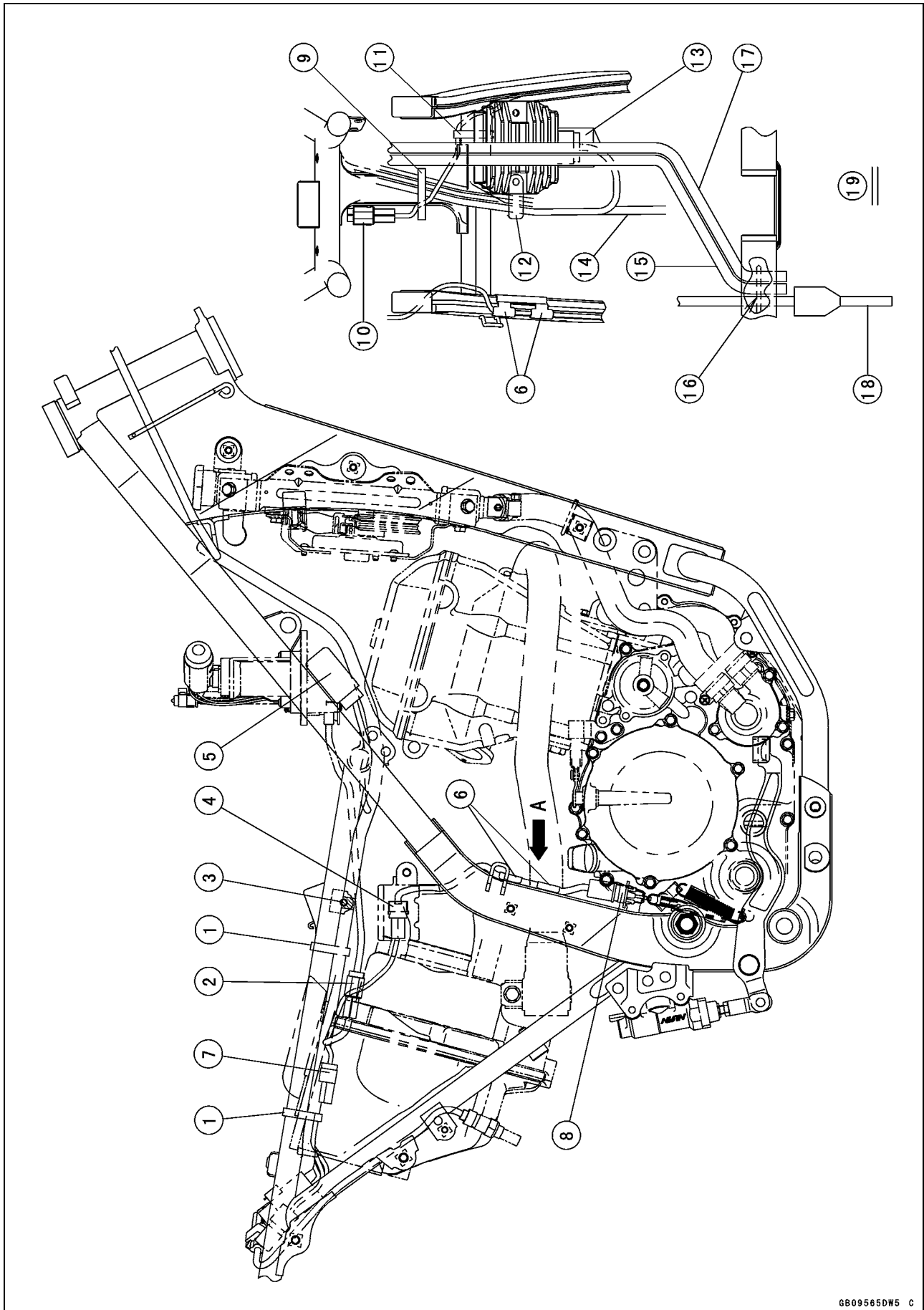

Cable, Wire, and Hose Routing

1. Band (Clamp the main harness.)
2. Fuel Pump Connector
3. Align the white mark on the main harness to the frame bracket.
4. Position the rear brake light switch connector at the inside of the rear brake reservoir tank.
5. Fuel Pump Relay
6. Run the rear brake light switch lead to the frame guide.
7. Kawasaki Diagnostic System Connector
8. Rear Brake Light Switch
9. Band (Clamp the starter motor cable, alternator lead, frame ground lead and sidestand switch lead.)
10. Sidestand Switch Connector (Run the lead under the starter motor cable, alternator lead and frame ground lead).
11. Band (Clamp the sidestand switch lead.)
12. Clamp (Clamp the starter motor cable, alternator lead and frame ground lead.)
13. Regulator/Rectifier Connector Cover
14. Alternator Lead
15. Fuel Tank Breather Hose
16. Run the fuel tank breather hose, drain hose and air cleaner drain hose to the guide of the swingarm.
17. Fuel Tank Drain Hose
18. Air Cleaner Drain Hose
19. Viewed from A

17-20 APPENDIX

Cable, Wire, and Hose Routing

Other than TH and KLX250S9F Early Model (TH)/V9F Early Model (TH)

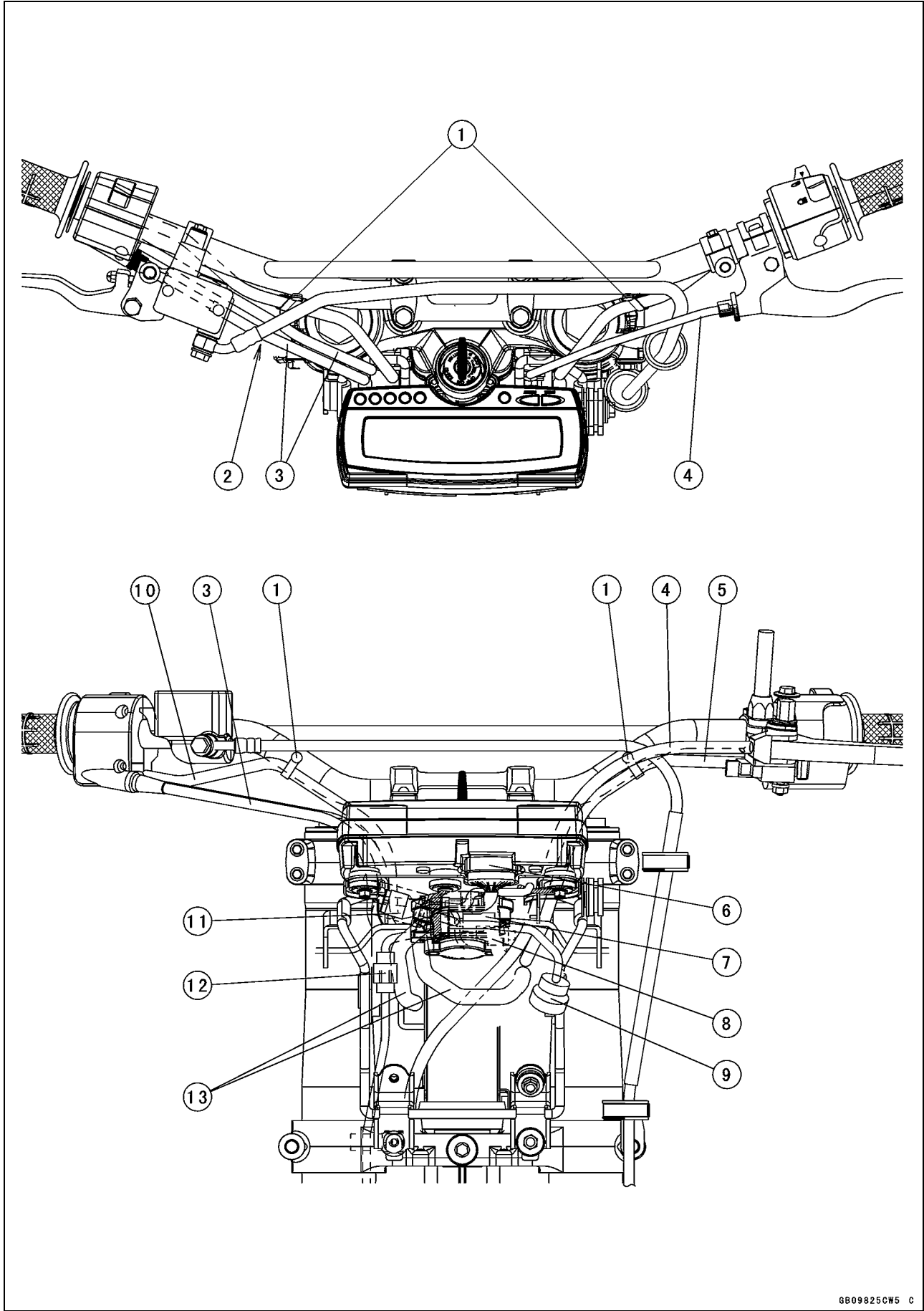

Cable, Wire, and Hose Routing

1. Clamp (Clamp the switch housing lead.)
2. Run the brake hose over the throttle cables.
3. Throttle Cables
4. Run the clutch cable forward of the front brake hose, and run it backward of the left and right switch housing leads and other lead wire. The clutch cable crosses the frame head pipe front from the left to the right.
5. Left Switch Housing Lead
6. Meter Unit Connector
7. Front Right Turn Signal Light Connector
8. Front Left Turn Signal Light Connector
9. Headlight Connector
10. Right Switch Housing Lead
11. Ignition Switch Connector (Cover the dust cover to the connector.)
12. Speed Sensor Connector
13. Clamp the main harness (left and right) at the position of the white mark.

17-22 APPENDIX

Cable, Wire, and Hose Routing

KLX250S9F Late Model ~ SBF (TH)/V9F Late Model ~ VAF (TH)

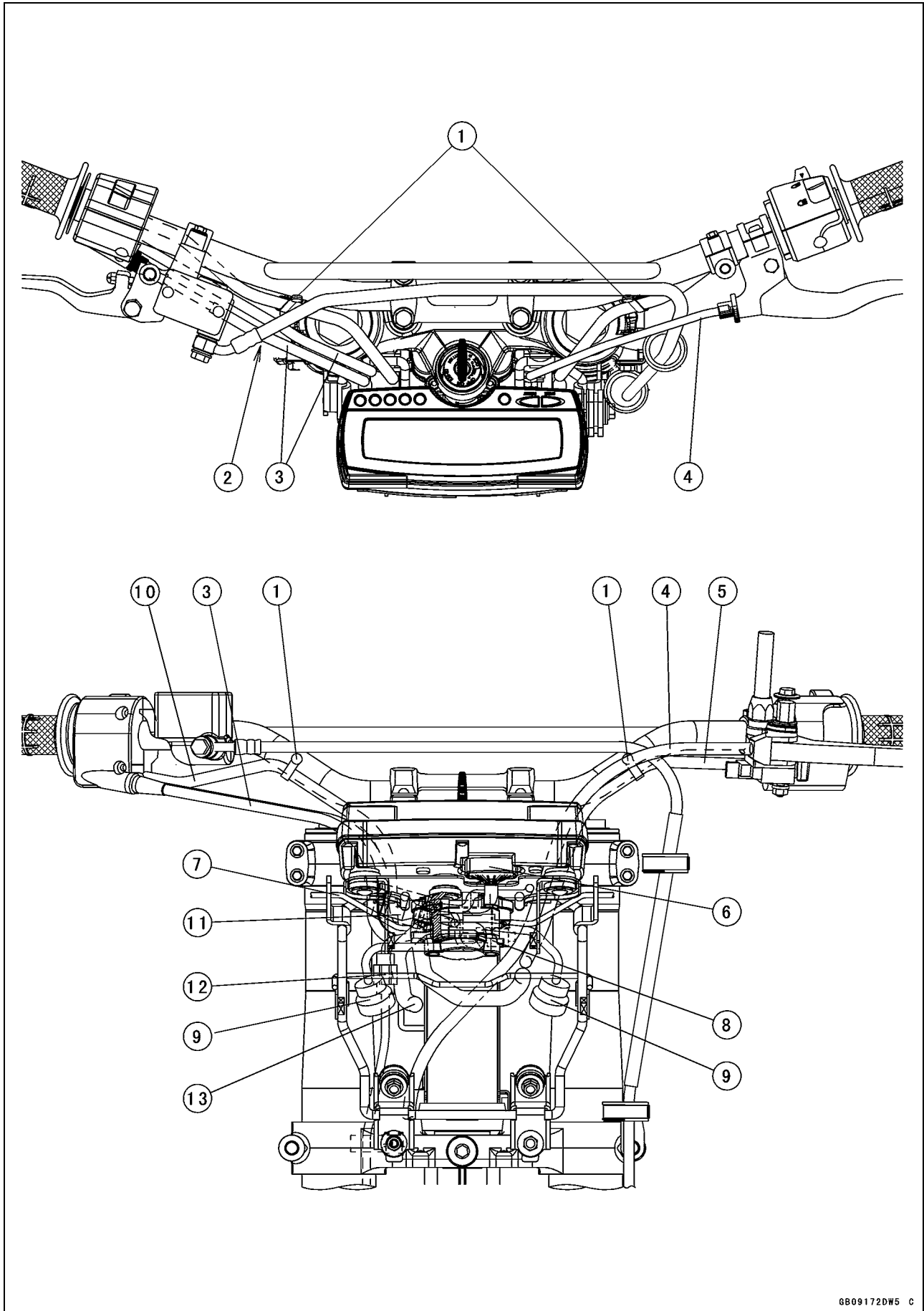

Cable, Wire, and Hose Routing

1. Clamp (Clamp the switch housing lead.)
2. Run the brake hose over the throttle cables.
3. Throttle Cables
4. Run the clutch cable forward of the front brake hose, and run it backward of the left and right switch housing leads and other lead wire. The clutch cable crosses the frame head pipe front from the left to the right.
5. Left Switch Housing Lead
6. Meter Unit Connector
7. Front Right Turn Signal Light Connector
8. Front Left Turn Signal Light Connector
9. Headlight Connector
10. Right Switch Housing Lead
11. Ignition Switch Connector (Cover the dust cover to the connector.)
12. Speed Sensor Connector
13. Clamp the main harness (left and right) at the position of the white mark.

17-24 APPENDIX

Cable, Wire, and Hose Routing

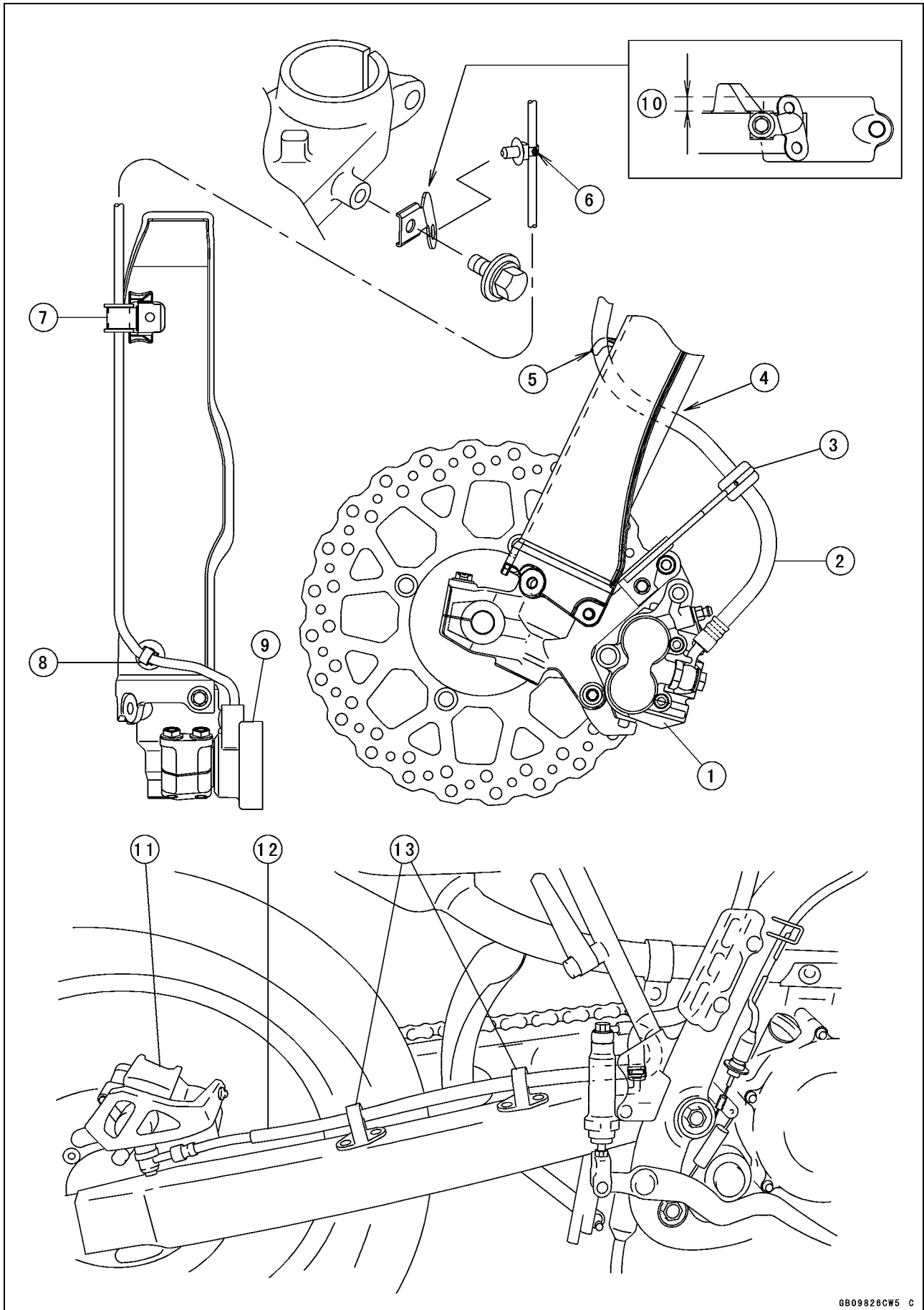

Cable, Wire, and Hose Routing

1. Front Brake Caliper
2. Front Brake Hose
3. Clamp
4. Run the front brake hose inside of the front fork.
5. Run the front brake hose along the guide on the fork protector.
6. Align the white mark on the speed sensor lead with the clamp.
7. Clamp
8. Clamp
9. Speed Sensor
10. Install the bracket so that its parallel to the steering stem.
11. Rear Brake Caliper
12. Rear Brake Hose
13. Run the brake hose to the holder.

17-26 APPENDIX

Cable, Wire, and Hose Routing

SEA and TH Models

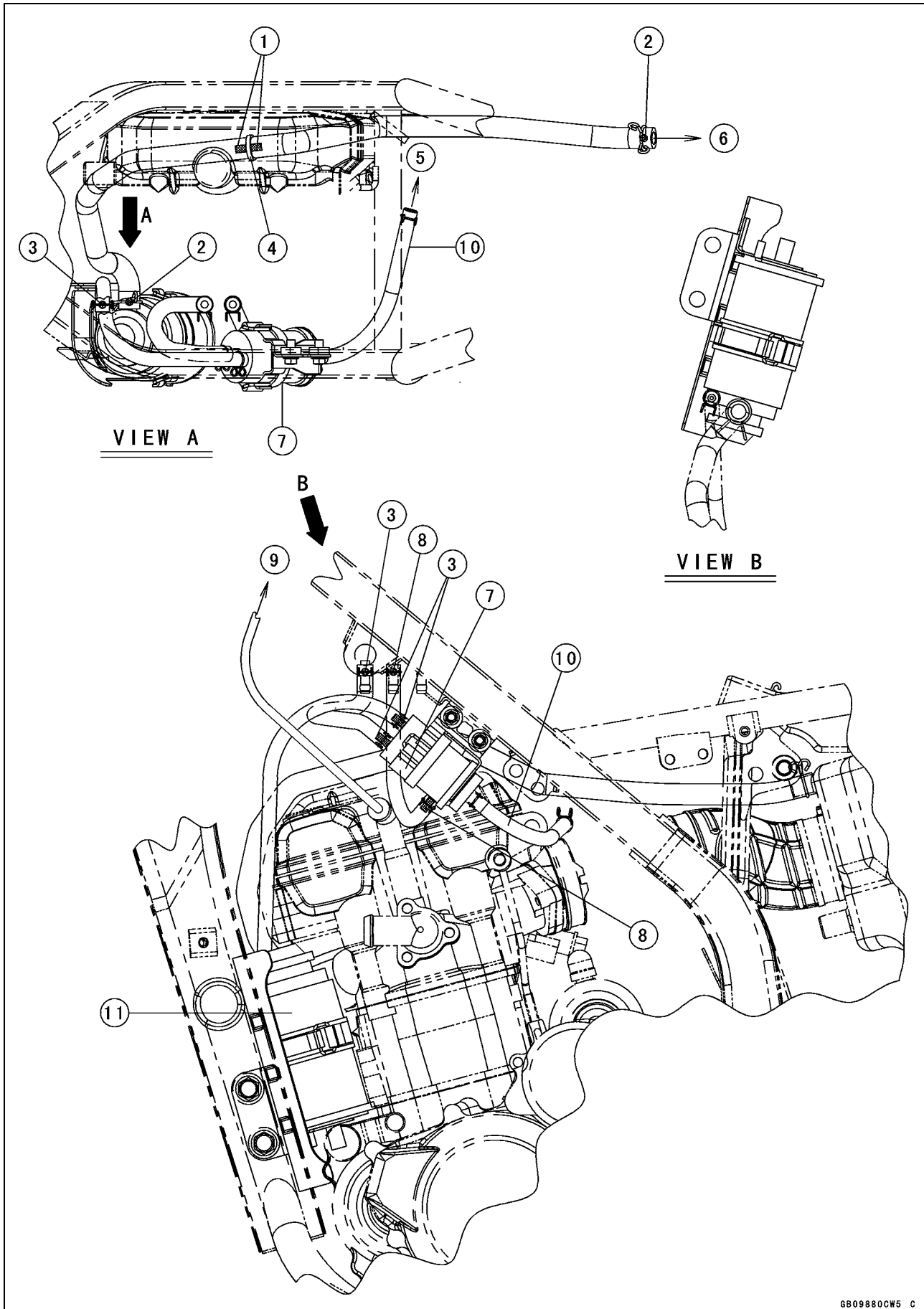

Cable, Wire, and Hose Routing

1. White Paints
2. Green Paints
3. Blue Paints
4. Fitting
5. To Throttle Body Assy
6. To Air Cleaner Housing
7. Separator
8. Red Paints
9. To Ignition Coil
10. White Line Hose
11. Canister

17-28 APPENDIX

Troubleshooting Guide

NOTE

- Refer to the *Fuel System* chapter for most of DFI trouble shooting guide.
- This is not an exhaustive list, giving every possible cause for each problem listed. It is meant simply as a rough guide to assist the troubleshooting for some of the more common difficulties.

Engine Doesn't Start, Starting Difficulty:

Starter motor not rotating:

- Starter lockout switch or neutral switch trouble
- Starter motor trouble
- Battery voltage low
- Starter relay not contacting or operating
- Starter button not contacting
- Wiring open or shorted
- Ignition switch trouble
- Engine stop switch trouble
- Fuse blown

Starter motor rotating but engine doesn't turn over:

- Starter clutch trouble
- Vehicle-down sensor (DFI) coming off

Engine won't turn over:

- Valve seizure
- Valve lifter seizure
- Cylinder, piston seizure
- Crankshaft seizure
- Connecting rod small end seizure
- Connecting rod big end seizure
- Transmission gear or bearing seizure
- Camshaft seizure
- Barancer Bearing seizure

No fuel flow:

- No fuel in tank
- Fuel pump trouble
- Fuel tank air vent obstructed
- Fuel filter clogged
- Fuel line clogged

Engine flooded:

- Clean spark plug and adjust plug gap
- Starting technique faulty
(When flooded, do not crank the engine with the throttle fully opened. This promotes engine flood because more fuel is supplied automatically by DFI.)

No spark; spark weak:

- Vehicle-down sensor (DFI) coming off
- Ignition switch not ON
- Engine stop switch turned OFF
- Clutch lever not pulled in or gear not in neutral
- Battery voltage low

- Spark plug dirty, broken, or gap maladjusted
- Spark plug cap or ignition coil cable trouble
- Spark plug cap shorted or not in good contact
- Spark plug incorrect
- IC igniter in ECU trouble
- Neutral, starter lockout, or sidestand switch trouble
- Crankshaft sensor trouble
- Ignition coil trouble
- Ignition switch or engine stop switch shorted
- Wiring shorted or open
- Fuse blown

Fuel/air mixture incorrect:

- Air cleaner clogged, poorly sealed, or missing

Compression Low:

- Spark plug loose
- Cylinder head not sufficiently tightened down
- No valve clearance
- Cylinder, piston worn
- Piston ring bad (worn, weak, broken, or sticking)
- Piston ring/groove clearance excessive
- Cylinder head gasket damaged
- Cylinder head warped
- Valve spring broken or weak
- Valve not seating properly (valve bent, worn, or carbon accumulation on the seating surface)

Poor Running at Low Speed:

Spark weak:

- Battery voltage low
- Spark plug dirty, broken, or maladjusted
- Spark plug cap or ignition coil cable trouble
- Spark plug cap shorted or not in good contact
- Spark plug incorrect
- IC igniter in ECU trouble
- Crankshaft sensor trouble
- Ignition coil trouble

Fuel/air mixture incorrect:

- Air cleaner clogged, poorly sealed, or missing
- Fuel tank air vent obstructed
- Fuel pump trouble
- Throttle body assy holder loose
- Air cleaner duct loose

Compression low:

- Spark plug loose
- Cylinder head not sufficiently tightened down
- No valve clearance

Troubleshooting Guide

Cylinder, piston worn
 Piston ring bad (worn, weak, broken, or sticking)
 Piston ring/groove clearance excessive
 Cylinder head warped
 Cylinder head gasket damaged
 Valve spring broken or weak
 Valve not seating properly (valve bent, worn, or carbon accumulation on the seating surface)

Backfiring when deceleration:

Air switching valve broken
 Air suction valve trouble

Other:

IC igniter in ECU trouble
 Engine oil viscosity too high
 Drive train trouble
 Brake dragging
 Air suction valve trouble
 Air switching valve trouble
 Engine overheating
 Clutch slipping

Poor Running or No Power at High Speed:

Firing incorrect:

Spark plug dirty, broken, or maladjusted
 Spark plug cap or ignition coil cable trouble
 Spark plug cap shorted or not in good contact
 Spark plug incorrect
 Camshaft position trouble
 IC igniter in ECU trouble
 Crankshaft sensor trouble
 Ignition coil trouble

Fuel/air mixture incorrect:

Air cleaner clogged, poorly sealed, or missing
 Air cleaner duct loose
 Water or foreign matter in fuel
 Throttle body assy holder loose
 Fuel to injector insufficient (DFI)
 Fuel tank air vent obstructed
 Fuel line clogged
 Fuel pump trouble

Compression low:

Spark plug loose
 Cylinder head not sufficiently tightened down
 No valve clearance
 Cylinder, piston worn
 Piston ring bad (worn, weak, broken, or sticking)
 Piston ring/groove clearance excessive
 Cylinder head gasket damaged
 Cylinder head warped
 Valve spring broken or weak

Valve not seating properly (valve bent, worn, or carbon accumulation on the seating surface)

Knocking:

Carbon built up in combustion chamber
 Fuel poor quality or incorrect
 Spark plug incorrect
 IC igniter in ECU trouble
 Crankshaft sensor trouble

Miscellaneous:

Throttle valve won't fully open
 Brake dragging
 Clutch slipping
 Engine overheating
 Engine oil level too high
 Engine oil viscosity too high
 Drive train trouble
 Air suction valve trouble
 Air switching valve trouble
 Catalytic converter melt down due to muffler overheating (KLEEN)

Overheating:

Firing incorrect:

Spark plug dirty, broken, or maladjusted
 Spark plug incorrect
 IC igniter in ECU trouble

Muffler overheating:

For KLEEN, do not push-start with a dead battery (Connect another full-charged battery with jumper cables, and start the engine using the electric starter)
 For KLEEN, do not start the engine under misfire due to spark plug fouling or poor connection of the spark plug
 For KLEEN, do not coast the motorcycle with the ignition switch off (Turn the ignition switch ON and run the engine)
 IC igniter in ECU trouble

Fuel/air mixture incorrect:

Throttle body assy holder loose
 Air cleaner duct loose
 Air cleaner poorly sealed, or missing
 Air cleaner clogged

Compression high:

Carbon built up in combustion chamber

Engine load faulty:

Clutch slipping
 Engine oil level too high
 Engine oil viscosity too high
 Drive train trouble
 Brake dragging

Lubrication inadequate:

Engine oil level too low
 Engine oil poor quality or incorrect

Coolant incorrect:

Coolant level too low

17-30 APPENDIX

Troubleshooting Guide

Coolant deteriorated
Wrong coolant mixed ratio

Cooling system component incorrect:

Radiator fin damaged
Radiator clogged
Thermostat trouble
Radiator cap trouble
ECU trouble
Radiator fan relay trouble
Fan motor broken
Fan blade damaged
Water pump not turning
Water pump impeller damaged

Over Cooling:

Cooling system component incorrect:

ECU trouble
Radiator fan relay trouble
Thermostat trouble

Clutch Operation Faulty:

Clutch slipping:

Friction plate worn or warped
Steel plate worn or warped
Clutch spring broken or weak
Clutch hub or housing unevenly worn
No clutch lever play
Clutch inner cable trouble
Clutch release mechanism trouble

Clutch not disengaging properly:

Clutch plate warped or too rough
Clutch spring compression uneven
Engine oil deteriorated
Engine oil viscosity too high
Engine oil level too high
Clutch housing frozen on drive shaft
Clutch hub nut loose
Clutch hub spline damaged
Clutch friction plate installed wrong
Clutch lever play excessive
Clutch release mechanism trouble

Gear Shifting Faulty:

Doesn't go into gear; shift pedal doesn't return:

Clutch not disengaging
Shift fork bent or seized
Gear stuck on the shaft
Shift drum positioning lever binding
Shift return spring weak or broken
Shift return spring pin loose
Shift mechanism arm spring broken
Shift mechanism arm broken

Jumps out of gear:

Shift fork ear worn, bent
Gear groove worn

Gear dogs and/or dog holes worn
Shift drum groove worn
Gear positioning lever spring weak or broken
Shift fork guide pin worn
Drive shaft, output shaft, and/or gear splines worn

Overshifts:

Shift drum positioning lever spring weak or broken
Shift mechanism arm spring broken

Abnormal Engine Noise:

Knocking:

IC igniter in ECU trouble
Carbon built up in combustion chamber
Fuel poor quality or incorrect
Spark plug incorrect
Overheating

Piston slap:

Cylinder/piston clearance excessive
Cylinder, piston worn
Connecting rod bent
Piston pin, piston pin hole worn

Valve noise:

Valve clearance incorrect
Valve spring broken or weak
Camshaft bearing worn
Valve lifter worn

Other noise:

Connecting rod small end clearance excessive
Connecting rod big end clearance excessive
Piston ring/groove clearance excessive
Piston ring worn, broken, or stuck
Piston ring groove worn
Piston seizure, damage
Cylinder head gasket leaking
Exhaust pipe leaking at cylinder head connection
Crankshaft runout excessive
Engine mount loose
Crankshaft bearing worn
Primary gear worn or chipped
Camshaft chain tensioner trouble
Camshaft chain, sprocket, guide worn
Air suction valve damaged
Air switching valve damaged
Alternator rotor loose
Catalytic converter melt down due to muffler overheating (KLEEN)

Abnormal Drive Train Noise:

Clutch noise:

Clutch housing/friction plate clearance excessive

Troubleshooting Guide

Clutch housing gear worn
Wrong installation of outside friction plate

Transmission noise:

Bearings worn
Transmission gear worn or chipped
Metal chips jammed in gear teeth
Engine oil insufficient

Drive line noise:

Drive chain adjusted improperly
Drive chain worn
Rear and/or engine sprocket worn
Rear wheel misaligned

Abnormal Frame Noise:

Front fork noise:

Oil insufficient or too thin
Spring weak or broken

Rear shock absorber noise:

Shock absorber damaged

Disc brake noise:

Pad installed incorrectly
Pad surface glazed
Disc warped
Caliper trouble

Other noise:

Bracket, nut, bolt, etc. not properly mounted or tightened

Exhaust Smokes Excessively:

White smoke:

Piston oil ring worn
Cylinder worn
Valve oil seal damaged
Valve guide worn
Engine oil level too high

Black smoke:

Air cleaner clogged

Brown smoke:

Air cleaner duct loose
Air cleaner clogged
Air cleaner poorly sealed or missing

Handling and/or Stability

Unsatisfactory:

Handlebar hard to turn:

Cable routing incorrect
Hose routing incorrect
Wiring routing incorrect
Steering stem nut too tight
Steering stem bearing damaged
Steering stem bearing lubrication inadequate
Steering stem bent
Tire air pressure too low

Handlebar shakes or excessively vibrates:

Tire worn

Swingarm pivot bearing worn
Rim warped, or not balanced
Wheel bearing worn
Handlebar clamp bolt loose
Steering stem nut loose
Front, rear axle runout excessive
Engine mounting bolt loose

Handlebar pulls to one side:

Frame bent
Wheel misalignment
Swingarm bent or twisted
Swingarm pivot shaft runout excessive
Steering maladjusted
Front fork bent
Right and left front fork oil level uneven

Shock absorption unsatisfactory:

(Too hard)
Front fork oil excessive
Front fork oil viscosity too high
Rear shock absorber adjustment too hard
Tire air pressure too high
Front fork bent
(Too soft)
Tire air pressure too low
Front fork oil insufficient and/or leaking
Front fork oil viscosity too low
Rear shock adjustment too soft
Front fork, rear shock absorber spring weak
Rear shock absorber oil leaking

Brake Doesn't Hold:

Air in the brake line
Pad or disc worn
Brake fluid leakage
Disc warped
Contaminated pad
Brake fluid deteriorated
Primary or secondary cup damaged in master cylinder
Master cylinder scratched inside

Battery Trouble:

Battery discharged:

Charge insufficient
Battery faulty (too low terminal voltage)
Battery lead making poor contact
Load excessive (e.g., bulb of excessive wattage)
Ignition switch trouble
Alternator trouble
Wiring faulty
Regulator/rectifier trouble

Battery overcharged:

Alternator trouble
Regulator/rectifier trouble
Battery faulty

MODEL APPLICATION

Year	Model	Beginning Frame No.
2009	KLX250S9F	JKALX250S□DA00001 or JKALX250SSDA00548 or LX250S-A00540
2009	KLX250V9F	LX250V-A00832
2010	KLX250SAF	JKALXMS1□ADA06540 or JKALX250SSDA06540 or JKALX250S□DA06535
2010	KLX250VAF	JKALXMV1□ADA03155
2011	KLX250SBF	JKALXMS1□BDA07967 or JKALX250SSDA07967 or

□:This digit in the frame number changes from one machine to another.



KAWASAKI HEAVY INDUSTRIES, LTD.
Motorcycle & Engine Company

Part No.99924-1392-04

Printed in Japan